

CITY OF REDLANDS
MUNICIPAL UTILITIES/PUBLIC WORKS COMMISSION
MEETING AGENDA
MONDAY, APRIL 4, 2022

ADEKUNLE OJO
Chairperson

STEVE STOCKTON
Vice Chairperson

R. BRAD THOMS
Commissioner

ZACHARY TRAVIS
Commissioner

THOMAS BREITKREUZ
Commissioner

DAVID GARCIA
Commissioner

CHANDRASEKAR 'CV'
VENKATRAMAN
Commissioner

4:00 PM Open Public Meeting
City Council Chambers
Civic Center, 35 Cajon Street, Redlands, California

Although the meeting is open to the public, seating has been reduced to allow for social distancing.

To join via Zoom on a computer, laptop, or smart device:
Please visit www.zoom.us, click on *Join a Meeting*
Enter the **Meeting ID 898 9918 5397**, then run the Zoom launcher

To join via Zoom with audio only (cell phone or landline):
Dial **1-877-853-5247**; Enter the **Meeting ID 898 9918 5397**

JOHN R. HARRIS
Municipal Utilities
& Engineering
Director

GOUTAM DOBEY
Engineering
Manager

KEVIN WATSON
Utilities Operations
Manager

Should the City lose connectivity on Zoom, we will halt the meeting until it can be restored. In the event the City cannot reestablish Zoom connectivity in a reasonable amount of time, the meeting will be adjourned to a future date.

Anyone desiring to speak on an agenda item at this meeting may do so during the consideration of that item. Depending on time constraints and the number of persons wishing to give oral testimony, public comments will be limited to three (3) minutes.

- To provide comment in person, simply raise your hand to speak*
- To provide comment through Zoom (on a computer, laptop, or smart device), click the "Raise Hand" button and the moderator will unmute you when it is your turn to speak*
- To provide comment via audio only (cell phone or landline), dial *9 to "Raise Hand" and the moderator will identify you by your area code and last 3 numbers of your telephone number when it is your turn to speak.*

The following comprises the agenda for the regular meeting of the Municipal Utilities/Public Works Commission of the City of Redlands.

CITY OF REDLANDS
MUNICIPAL UTILITIES/PUBLIC WORKS COMMISSION
MEETING AGENDA
MONDAY, APRIL 4, 2022

A. ATTENDANCE & CALL TO ORDER

B. PUBLIC COMMENT

(Any person wishing to provide public comment may do so at this time.)

C. APPROVAL OF MINUTES

- a. **February 7, 2022 Regular Meeting Minutes**

D. COMMUNICATIONS

- a. **Director's Report**
- b. **Commission Liaison Updates**
 - i. **MUPWC's Annual Report to the City Council**

E. PRESENTATION

- a. **Presentation from Richard Brady & Associates, Inc. on the Water Infrastructure Condition, Seismic and Structural Assessment**

F. NEW BUSINESS

- a. **Discussion of the Updated Wastewater System Master Plan and Possible Recommendation to City Council for Adoption**

G. COMMISSIONER ANNOUNCEMENTS, REPORTS ON ACTIVITIES, AND/OR REQUEST FOR FUTURE AGENDA ITEMS

H. ADJOURNMENT – Next Meeting is June 6, 2022 @ 4:00 pm

ATTACHMENTS:

- 1. Draft Minutes of February 7, 2022 Regular Meeting**
- 2. Director's Report**

DRAFT
(for MUPWC review on 4/4)
MINUTES

Regular meeting of the City of Redlands Municipal Utilities/Public Works Commission on February 7, 2022 at 4:00 PM in the Council Chambers at the Civic Center, 35 Cajon Street. The meeting was an in-person meeting with teleconferencing available via Zoom. Votes were conducted in person and by roll call.

A. ATTENDANCE & CALL TO ORDER

Present: Adekunle Ojo, Chairperson
Steve Stockton, Vice Chairperson
Chandrasekar 'CV' Venkatraman, Commissioner
David Garcia, Commissioner
Thomas Breitzkreuz, Commissioner
R. Brad Thoms, Commissioner
Eddie Tejada, Council Liaison/Mayor Pro Tempore

Staff: John Harris, Municipal Utilities & Engineering Director; Goutam Dobey, Engineering Manager; Kevin Watson, Utilities Operations Manager; Veronica Medina, Assistant Engineer; Kyle Wagner, Construction Manager (joined remotely); Johana Silva, Commission Liaison/Assistant Engineer; Jane Weathers, Senior Administrative Assistant; Fernando Mata, Wastewater Operations Superintendent (joined remotely)

Guest

Consultants: Elizabeth Calva, P.E. and Russ Bergholz, P.E. with Dudek, Inc., (joined remotely)

Chairperson Ojo called the meeting to order at 4:02 PM, thanked and welcomed everyone for attending, and offered any public present the opportunity to provide comment on any item on the agenda.

B. PUBLIC COMMENT

None forthcoming.

C. APPROVAL OF MINUTES

The minutes of the regular meeting of December 6, 2022, were unanimously approved.

Vote: 5 – 0 Passed

D. COMMUNICATIONS

a. **Director's Report**

DRAFT
(for MUPWC review on 4/4)
MINUTES

Director Harris welcomed everyone to the meeting and provided highlights to his Director's Report. Director Harris recapped the regressive capital improvement projects (CIP) delivery schedule for this year. A total of 27 new CIP for potable, non-potable water and wastewater projects were completed or will be initiated this fiscal year excluding the ongoing street rehabilitation project, grant projects and wastewater improvement project.

Updates were provided on the following:

Tate Influent Line – A RFP has been issued.

Well and Booster Pump Rehab Project – Reorganization of the project occurred which consisted of two wells moving from Phase 3 to Phase 1. The project is remaining within the approved budget.

Wastewater Treatment Plant Project, Phase 2 (WWTP P2) – A loan application was submitted for the State Revolving Fund. A response is expected to receive by May 2022 and approval of the application is generally given by July. WWTP P2 is tentatively scheduled for bid in June pending the completion of the design.

Wastewater Treatment Plant Project, Phase 1B (WWTP P1B) – The final permit was received to construct and operate the gas conditioning system. WWTP P1B is scheduled to be complete by June 2022.

Sunset Reservoir Replacement Project – Staff has no further advancement on the land acquisition related to the Sunset Reservoir. Staff is evaluating this option for the project and will keep the commission apprised of this item.

Water Meter Replacement Project – An update was provided on the Phase 1 of a 5 year water meter replacement project replacing all potable and non-potable water meters within Redlands' service area and includes the installation of Automated Metering Infrastructure (AMI). This project along with all citywide project are impacted by the supply chain issues. During an audit of the meters, Staff has identified additional factors contributing to water loss in the system. This includes meters that were not in the system and adjacent 6" and 2" diameter meters lines running concurrently. Staff has issued notices to customers affected by the discrepancies.

Pavement Management Program (PMP) – The current PMP project, contracted to Matich Corporation, is on schedule and on budget.

Condition, Seismic and Structural Assessment – The completion of the final draft assessment will be completed by the end of March 2022. One issue identified in the assessment is the replacement of the Tate Water Treatment Plant influent line.

WWTP Recycled Water Reservoir – The Sunset Reservoir design will not be packaged with the design of the two recycled water reservoirs due to the option to purchase land property for the future construction of a larger reservoir. A separate contract was awarded to Carollo Engineers to design the two recycled water reservoirs at the WWTP to store water for a more beneficial use.

Sidewalk/ADA Ramp Replacement Project – With Phase 1 of the project complete, Staff is currently compiling Phase 2 of the project which is set to go out to bid by the end of the fiscal year.

Water System SCADA Design & Integration – Staff issued a contract to TESCO Controls, Inc. for the final phase of the SCADA improvement. Staff combined this project with the PLC Controller of the Tate Water Treatment Plant for a more competitive bid price.

WWTP Cogeneration System – No update was provided on the cogeneration system at the wastewater plant to reuse digester gas boiler system emissions. Staff is not pursuing this project at this time due to internal staffing capacity, however Staff sees the value in this project and will evaluate it at a future date.

Commission inquiries ensued regarding clarification of the adjacent 6" and 2" diameter water meter lines, meter accuracy, recovery of fixed charges, and combining GIS and asset management system to decrease future errors.

DRAFT
(for MUPWC review on 4/4)

MINUTES

Mr. Watson clarified that the meters discussed earlier were a 6" meter with a 2" bypass and a dial on the 6" line. Mr. Watson stated that an assumption error was made of the 2" line being used as a domestic line and the 6" line for fire. He continued to state that due to age and the quantity of flow the meters are not correctly registering the amount of flow. Mr. Harris clarified that the customers affected by the meter discrepancies will not be back charged, however Staff will correct the issue and alert customers that charges may increase. Mr. Harris agreed with the commission suggestion that combining asset management system and GIS will be beneficial in reducing error.

Inquiries ensued regarding the timeline for WWTP P2. Mr. Harris reiterated that no notification has been received for the State Revolving Fund. The approval of the application is generally given in late June or early July. WWTP P2 is tentatively scheduled for bid in June or early July pending the completion of the design. The construction documents will have language stating contingency on funds. The notice to proceed will be issued around September 2022.

Commissioners asked for an explanation of the gas conditioning system. Mr. Watson explained the gas conditioner with the new boilers will meet AQWD exhaust emission regulations. The boiler typically runs on natural gas or conditioned gas from the digesters with the option to run on either source. He clarified the boilers usually run on the conditioned digester gas with the natural gas as a backup. A suggestion was made by the commission to use the exhaust gas to heat the digester sludge during the cogeneration phasing.

A question was asked by the Commission if testing of smaller 1" diameter residential meters was performed for comparison to the new meters. Mr. Harris explained replacement of the meters will not take place in Water Meter Replacement Project, Phase 1. The commission suggested that data should be analyzed to determine the percentage of water flow by meter size to prioritize meter replacement. Mr. Watson explained a random sample of meters were tested for accuracy, during which the larger meters did not obtain readings for flow under 35 GPM. Similarly, small meters did not obtain readings under 5 GPM which led to a 20% inaccuracy. Mr. Harris stated that Staff is evaluating a possible project of an automated meter reading infrastructure project. The City received a cost estimate from Ferguson, the regional Neptune water meter provider. Staff is currently verifying possible carry-over funding for AMI implementation. Suggestions were made by the commission to consider planning and managing the lifecycle of meters and track installation date, and to install meters with AMI capability to ease the translation to AMI at a future date. Mr. Harris clarified that meters will be installed with encoder receiver transmitters, retrofitted with new antennas, and ready to be incorporated into AMI.

b. Commission Liaison Updates

- i. 2022 Calendar for MUPWC**
- ii. MUPWC's Annual Report to the City Council**

Ms. Silva stated that the 2022 MUPWC calendar with all regular meeting dates is included in the agenda packet for the commissioner's reference. Ms. Silva stated as in previous years, City commissions and committees provide annual updates to the City Council. The update may be the calendar year or rolling year from their last annual report. The Commission was asked to determine who would present and an alternative presenter. It was determined by his peers that Chairperson Ojo would present to City Council on behalf of the Commission with Steve Stockton as an alternate. A tentative date of June was set for the MUPWC to report to Council to allow the commission to review the annual report during the next commission meeting.

DRAFT
(for MUPWC review on 4/4)
MINUTES

E. NEW BUSINESS

a. Discussion of the Proposed Updated Citywide Master Plan for Wastewater System and Possible Recommendation to City Council for Adoption

Mr. Harris informed the commission on a current project recommended in the proposed Citywide Master Plan for Wastewater System. The City Manager authorized an emergency procurement to allow the payment of the incremental cost difference to upsized a 24" pipeline to a 36" pipeline (as shown in the proposed master plan) currently located east of Alabama Street between Palmetto Avenue and Pioneer Avenue. The commission stated that the current master plan should be edited to reflect the consideration that is being addressed at this point and time. A suggestion was made to include the definition of a syphon for clarity and regular brine testing as a standard operating procedure. Elizabeth Calva, with Dudek, explained that the definition of syphon is included in the master plan. A request was made by the commission to move this item to the April 2022 regular meeting to allow additional time for the commission to review the report.

F. COMMISSIONER ANNOUNCEMENTS, REPORTS ON ACTIVITIES, AND/OR REQUESTS FOR FUTURE AGENDA ITEMS

Items requested for the next regular Commission meeting agenda were as follows:

Wastewater Master Plan – Further discussion of the proposed updated citywide master plan for the wastewater system and possible recommendation to City Council for the adoption of the plan.

Water Master Plan, Potable and Non-Potable – Discussion of the proposed citywide master plan for the water master plan, potable and non-potable, for the commission's review during the April commission meeting and a possible recommendation during the June commission meeting.

Economics of the Water Conservation Program – Discussion on each of the rebate types, water saving estimate, evaluation if water saving estimate is met, and cost of the program. The commission requested an evaluation of the impact of the influent water coming to the wastewater treatment plan due to the program.

Water Resources – Comprehensive discussion on water resources, water entitlements, and water exchange agreements.

Departmental Structure – The commission requested an update on how the department is structured and how restructure brings value to residents.

G. ADJOURNMENT – Next regular meeting is April 4, 2022 at 4:00 PM

There being no further business the meeting adjourned at 4:52 PM. The next regular meeting of the City of Redlands Municipal Utilities/Public Works Commission is scheduled for April 4, 2022.



City of
REDLANDS
Incorporated 1888
Municipal Utilities & Engineering Department

JOHN R. HARRIS
Director

MEMORANDUM

TO: Adekunle Ojo, Municipal Utilities/Public Works Commission Chair

FROM: John R. Harris, Municipal Utilities & Engineering Department Director

DATE: April 4, 2022

SUBJECT: April 2022 Director's Report

Hello and thank you for serving the Redlands community as a Municipal Utilities/Public Works Commissioner (MUPWC)! City of Redlands Municipal Code Chapter 2.38 establishes the responsibilities of the MUPWC as follows:

"The commission is a resource for the City Council and City staff and buffer with the general public. In its advisory capacity, the commission shall be knowledgeable of all public works, utilities and engineering programs. The commission shall, through the individual and collective expertise of its members, provide advice to the Public Works and Municipal Utilities Departments regarding the public acceptability of proposed plans, programs and projects."

Annual City Council Report

The June City Council meeting dates are June 7th and June 21st, although the June 21st meeting will likely be reserved for adoption of the FY 22/23 City budget. The MUPWC meets next on June 6, 2022. A draft Annual City Council Report presentation is provided as Attachment "A".

Wastewater Master Plan – City Council Recommendation

The Commission received a copy of the Dudek Wastewater Master Plan in December 2021. Tonight the Commission will discuss the Master Plan and develop a City Council recommendation. The Master Plan is included as Attachment "B".

Utility Systems Cyber Threats

MUED has, and will continue to closely monitor and defend against cyber threats to minimize impacts to Water and Wastewater utility systems operations. At one time, the Hinckley WTP and Tate WTP were monitored and operated by two (2) separate SCADA systems. In 2012, the

systems were upgraded and consolidated onto a single network controlled by radio (primary) and/or ISP (backup). We intend to build a redundant local system to operate the plants outside of a network failure when the current SCADA Improvement Project is complete. In the meantime, MUED is able to manually operate both plants with around-the-clock staffing if necessary. The WWTP hardware, operating systems, programming, and network configurations are all documented on every device to restore to normal if a catastrophic failure occurs. All files are stored on a dedicated server and are backed up off-site. If the WWTP SCADA and internet service fail, a landline auto-dialer notifies operations staff of the specific location and device failure. WWTP staff will respond to resolve these issues when necessary. Again, MUED is able to manually operate the WWTP with around-the-clock staffing if necessary.

Water Conservation Program Analysis

MUED is conducting a comprehensive analysis of this program, to include:

- Rebate Totals – Number and cost of each rebate type;
- Estimated Water Savings;
- Analysis – Actual water use reduction for each rebate and program cost for each unit of water saved.

In the meantime, here are a few program statistics:

- Total Rebates (since program inception):

○ High-Efficiency Toilet	523	EA
○ Irrigationless Conversion	159,253	SF
○ High-Efficiency Washing Machine	110	EA
○ Weather-Based Irrigation Controller	350	EA
○ High-Efficiency Sprinkler Nozzle	10,025	EA
○ Drought-Tolerant Plant Conversion	436,274	SF
- Total Estimate Water Savings: 4,320 AF
- 1,154 customers have received rebates
- 2,545 customer assistance site visits

Water System Master Plans

In September 2020, Michael Baker International, Inc. (MBI) was hired to develop Water System Master Plans (MP) for the potable, non-potable, and recycled water systems. The project scope of work required separate potable water system and non-potable/recycled water system MP documents. Although the project began well, the MBI Project Manager (PM) became non-responsive in early 2021. After repeated attempts to resolve this issue, MBI eventually disclosed that their PM was no longer with the company, and that MBI was assembling a new team to continue the project. Soon after, a new MBI PM was identified, and the project progress resumed.

In fall 2021, I became concerned with what I perceived to be the slow project pace, and overall value of the MBI PM appeared to bring to the project. I discussed my concern privately with two (2) MBI Vice Presidents, who assured me the role of their PM would become clear when development and assembly of the MP documents began. In January 2022, MUED received a first draft of the Potable Water System MP. It was very poorly written and included many grammar, punctuation, and technical errors. After spending several hours reviewing the fifteen (15) page Executive Summary, I redirected the MUED staff to focus on other projects, sent my review comments directly to the two (2) MBI Vice Presidents I spoke with earlier, and suggested that the MBI team should assign another employee to independently review the document. On February 8, 2022, MUED staff received a revised document that was written better, but still included many errors. On February 14, 2022, MUED staff received a first draft of the Non-Potable/Recycled Water System MP, which was as poorly written as the Potable Water System MP first draft. I did not bother asking MBI to revise and improve this document.

During the next couple weeks, the MUED staff essentially re-wrote both MP documents and merged the separate MP documents into a single Water System Master Plan (WSMP). This consolidated WSMP was refined during several internal review meetings to produce a well written, technically accurate document that meets reasonable quality standards. The WSMP is based on hydraulic modeling performed by MBI, which is excellent, and accurately represents existing system configurations and deficiencies, future system demands, and construction cost estimates. The MUED staff has received the hydraulic model electronic file, and will soon purchase Innovzye hydraulic modeling software. MUED employees will receive Innovzye training to support future system scenario modeling efforts.

A printed review copy of the WSMP is being provided to each Commissioner tonight, with the goal of developing a City Council recommendation during the June 6 MUPWC meeting. This WSMP was still being finalized when the April 4, 2022 MUPWC meeting packet was distributed, and is not attached to this report.

MUED Organizational Structure

The MUED structure has been refined during the last year and a half to improve service delivery and to better align with my management style. During the last thirty (30) years, I have managed small organizations with sixty (60) employees and large organizations with 800 employees, with Operating and CIP Budgets between \$12M and \$1B. I believe a relatively flat organizational structure with logical functional divisions improves the span of control for supervisors, and allows MUED to provide high-quality services to customers at affordable rates. Here is a brief summary of MUED organizational structure improvements made during my tenure:

1. Administration/Water Resources Division – When I became the MUED Director, this Division included a Manager, a Management Analyst, an Administrative Analyst, three (3) Administrative Assistants, a Water Resource Specialist, a Water Conservation Specialist, two (2) Water Waste Investigators, and a Part-Time Technical Services Clerk.

This Division has been dissolved, and employees have been formally assigned to MUED Managers and Superintendents they were already supporting functionally. Through attrition, the administrative staff has been reduced to three (3) full-time employees, one (1) for each MUED fund (Water, Wastewater, General Fund), and one (1) part-time employee. The Manager, Management Analyst, and Administrative Analyst positions were eliminated through attrition. The water conservation staff was reassigned to the Engineering Division.

2. Engineering Division – Two (2) vacant Associate Engineer positions have been filled. One (1) of these positions is currently shared with the Facilities and Community Services Department (25% MUED/75% FCS). The Senior Environmental Compliance Inspector retired and was replaced with a NPDES Inspector.
3. Wastewater Division – One (1) Wastewater Collections Line Maintenance position has been added to create two (2) full work crews. Two (2) Grounds Maintenance Workers were reassigned to the FCS Department. All Joint Utility Laboratory Technicians were reclassified a Laboratory Analysts to maintain laboratory accreditation. The Laboratory Supervisor retired and was replaced with a Laboratory Manager, also to maintain laboratory accreditation.
4. Water Production Division – A Senior Water Treatment Operator position has been vacant for more than two (2) years, and will soon be under-filled as a Water Treatment Operator.
5. Water Distribution Division – No significant changes.

In December 2020, the MUED staff totaled 106.

In July 2022, the following additional MUED organizational structure changes will occur:

1. Engineering Division – The Engineering Manager position will be reclassified as a City Engineer position. One Stop Permit Center employees (7 FTEs & 1 PTE) will be reassigned to the Development Services Department to merge with the Building & Safety Division. This consolidates all construction permitting within a single City department. The Construction Inspection team will be removed from the Engineering Division to form the new Streets & Inspections Division. The Water Waste Investigator positions (PTE x 2) will be eliminated, and a FTE Code Enforcement Officer will be added to the FCS Department. All Code Enforcement Officers will be cross-trained to enforce the Redlands Municipal Code Water Conservation provisions.
2. Streets & Inspections Division – The Street Maintenance Division (15 FTEs) will be reassigned to MUED, and the MUED Construction Manager will oversee this new MUED Division. One (1) NPDES Inspector, currently assigned to the One Stop Permit Center, will remain in MUED, and will be assigned to this Division.
3. Wastewater Division – Three (3) Wastewater Collections Line Maintenance positions will be added to create three (3) full work crews. A new Wastewater Maintenance Foreperson position will be added to replace a Utility Maintenance Foreperson position

currently shared with the Water Production Division. Two (2) Wastewater Operations Apprentice positions will be eliminated.

4. Water Production Division – The shared Utility Maintenance Foreperson position will be reclassified as a dedicated Water Production Maintenance Foreperson position.
5. Water Distribution Division – Currently there are three (3) Water Distribution Crew Leader positions (2 vacant) and four (4) Senior Water Distribution Operator positions (1 vacant) with virtually identical job descriptions. The three (3) remaining Senior Water Distribution Operator positions will be reclassified as Water Distribution Crew Leader positions, and the Senior Water Distributor Operator positions will be eliminated. This reduces the number of Water Distribution Division positions with supervisory and/or technical leadership responsibility from nine (9) to six (6), while retaining the overall staffing level of twenty-six (26). Three (3) Water Operations Apprentice positions will be eliminated.

When these changes occur, the total MUED staffing will be 109. The FY 22/23 MUED organizational chart is provided as Attachment “C”.

Update WWTP P2 Project Update

Parsons Engineering continues to develop and refine the WWTP Improvement Project Phase 2 design, and has made significant progress toward completion of the following design elements:

Task 1 – Conduct Facility Condition Assessment	P1 = 100%/P2 = 90%
Task 2 – Develop Multipurpose Project Report/Implementation Plan	100% Complete
Task 3 – Provide Engineering Design Services	P1 = 100%/P2 = 50%
Task 4 – PM, Communication, QC	P1 = 100%/P2 = 60%

This project is on-schedule and on-budget. MUED submitted a \$45M State Revolving Fund loan application for construction of these improvements prior to the December 31 submittal deadline, and received notification that the application rating exceeds the minimum scoring threshold for loan approval.

Sunset Reservoir Replacement – Land Lease Agreement

MUED recently negotiated a Lease Agreement with the land owners adjacent to the Sunset Reservoir site that will allow a temporary reservoir to be constructed on their property prior to demolishing and reconstructing a new permanent reservoir. The concept to purchase this property for the future construction of much large reservoirs cannot be refined until a calibrated water model is available. We anticipate this model will be available in late-March 2022. MUED recently received the results of an independent land appraisal for this property, and will discuss the results with City Council in Closed Session on April 5, 2022.

Water Meter Replacement Project

We have begun a five (5) year project to replace all potable and non-potable water meters within the Redlands service area. Ferguson Waterworks was selected to supply and install the water meters, meter box lids, and Automated Metering Infrastructure (AMI) hardware for use in the future. Ferguson has begun replacing meters, and nearly fifty percent (50%) complete, with 1,132 meters replaced and/or retrofit and 1,300 remaining.

Phase I (FY 21/22) of the project, detailed below, includes replacing older meters, and retrofitting recently replaced meters with AMI hardware:

SIZE	REPLACEMENTS	RETROFITS
5/8"	24	7
3/4"	537	463
1.0"	500	215
1.5"	112	85
2.0"	174	95
3.0"	55	15
4.0"	31	12
6.0"	16	10
8.0"	10	3

Prior to ordering water meters, MUED staff physically audited each location to confirm the type and size of each water meter. The audit identified several large diameter water meters that are not listed in the billing system, are bypassed in some manner, or have not been read correctly in the past. Each of these issues will be resolved with this project, and the non-revenue water rate will significantly decrease in the future. This project is on-schedule (June 30, 2022 completion date) and on-budget. An updated Project Location Map is included as Attachment "D".

PMP Update

We combined the FY 20/21 and FY 21/22 PMPs into a single project, added necessary sanitary sewer collection system improvement elements, and issued a new RFB in early-July. The total budget, which is a combination of the FY 20/21 PMP, FY 21/22 PMP, and Wastewater Collection System Improvement budgets, is \$9,362,966 (\$4,901,966, \$4,000,000, and \$461,000 respectively). On July 21, we received bids from three (3) paving contractors. Matich Corporation submitted the lowest bid of \$9,235,780, which is approximately two percent (2%) below the approved project budget. City Council awarded a Construction Contract to Matich on September 7, 2021. MUED hosted a project kick-off meeting on September 20, 2021, and the project will be completed in June 2022 (approximately 60% complete currently).

Matich has completed concrete curb/gutter replacements in all areas. The sewer pipe replacement portion of the project is complete. Matich has completed paving activities in Area A, B, C and F, and is currently completing paving work in Areas D and E. An updated project location map is provided as Attachment "E".

2021 Q3 Capital Improvement Project Update

The MUPWC is charged with, among other things, “*annually reviewing the City CIP under the purview of the Public Works and Municipal Utilities Departments*” (Municipal Code 2.38.030). However, during the December 7, 2020 MUPWC meeting, the Commission asked the MUED staff to provide quarterly CIP updates. A summary and status of CIP projects is provided in Attachment “F”.

As you know, the FY 21/22 CIP delivery schedule is aggressive, and success requires thoughtful project coordination and planning. To meet this obligation, MUED issued several RFBs and developed Sole Source Waiver recommendations for City Council consideration on June 15, which was the first meeting after approval of the FY 21/22 Operating Budget. That strategy is working well, particularly considering the unanticipated supply chain related delays all projects are experiencing, and our CIP delivery is progressing well. Highlights of current project are provided below:

1. Multi-Year Well Rehabilitation & Booster Pump Replacements – Five (5) potable water wells, two (2) non-potable water wells, and two (2) booster pumps are being rehabilitated in FY 21/22 through a single task order. Additional task orders will be issued in each of the next two (2) fiscal years through contract extensions to rehabilitate thirteen (13) more wells, although MUED may recommend accelerating this schedule. Following is a detailed summary of tasks with their progress:
 - a. Task 1.1 (Airport Well) – Currently scheduling brushing and pump pedestal improvements. Video was completed March 9, and is being reviewed. Estimated project completion is the week of 3/28/22;
 - b. Task 1.2 (Church Street Well) – This task has been moved to a future Project phase to accelerate rehabilitation of the Muni Well under the terms of a cost-share agreement with San Bernardino Valley Municipal Water District. The Muni Well pump and other components have been removed, and are being inspected. Estimated time for completion is 6-8 weeks (week of 5/20/22);
 - c. Task 1.3 (East Lugonia 3 Well) – Complete;
 - d. Task 1.4 (East Lugonia 6 Well) – In progress. Well pump and piping have been pulled and video performed. Estimated completion date is late-March;
 - e. Task 1.5 (N Orange 1 Well) – In progress. Brushing and bailing is complete. Estimated completion date is late-March;
 - f. Task 1.6 (31A Well) – In Progress. Brushing, bailing, video survey, and pump testing are complete. New pump and motor have been set. Currently working on piping connections and electrical upgrades. Estimated completion date is May 9, 2022;
 - g. Task 1.7 (32 Well) – This task will begin upon completion of task 1.6. Estimated completion date is August 8, 2022;
 - h. Task 1.8 (2310 Booster) – Complete;

- i. Task 1.9 (2311Booster) – In progress. Pump and equipment have been ordered. Estimated completion in mid-April 2022;
2. Water Infrastructure Condition, Seismic, & Structural Assessment – Richard Brady will provide an in-person project summary.
3. Recycled Water Reservoir Engineering – A Request For Proposals was recently issued for this project. Proposals were received by three (3) consultants, and City Council approved a Professional Services Contract with Carollo Engineers in January 2022. A project Kick-Off Meeting was hosted on January 31, 2022, and several data gathering and analysis meetings have occurred since then.
4. Citywide Sidewalk and ADA Ramp Replacements Phase 1 has been completed. Staff is developing Phase 2 construction plans for the project and anticipate construction will begin in late-spring 2022.
5. Tate WTP Raw Water Influent Pipeline Engineering – A Request For Proposals was recently issued for this project, and Carollo Engineers submitted the only proposal. A project Scoping Meeting was hosted on March 14, 2022. City Council will consider approval of a Professional Services Agreement on April 19, 2022.
6. Hinckley WTP Sludge Press Engineering – A Request For Proposals was recently issued for this project, and Dudek submitted the only proposal. A project Scoping Meeting was hosted on March 16, 2022. City Council will consider approval of a Professional Services Agreement on April 19, 2022.

Procurement of the remaining FY 21/22 CIP work will occur within the next few weeks. The Well Perchlorate Treatment Evaluation scope of work is being developed.

Wastewater Treatment Plant Project Update

As you know, Phase 1A of the WWTP Rehabilitation Project was successfully completed and accepted in November 2020. GSE Construction Company, Inc. was awarded a contract to construct Phase 1B of the Project in November 2020. The project includes supplying and/or installing the following equipment, which has been plagued by significant COVID-19 related delays:

1. Fine Screens and Associated Equipment: Removes objects to prevent damage to the newly installed MBR filters.
 - a. Status: Installation completed with the exception of a large valve; Commissioning is on hold pending completion of the IPW system.
2. Ejector Priming System Upgrades: Removes air from the permeate vessel to prevent air locking of pumps.
 - a. Status: Installed and commissioned.
3. Scour Blowers and Associated Equipment: Creates air scouring, which provides premium efficiency and cost savings to the City. The blowers operate on a 24-hour basis, producing scour air that backwashes the filter media.

- a. Status: Installed and commissioned. This portion of the project resulted in a total energy savings of more than 1.5 million kilowatt hours per year, and earned the City a Southern California Edison incentive payment of \$290K.
4. Digester Boilers and Heat Exchangers: Maintains proper temperature for bacteria to decompose sewage sludge and produce digester gas.
 - a. Status: Underground ductwork complete and above ground conduits currently being installed; Demolition of boilers for digester 3 is complete. Gas conditioning system is installed and initial startup is complete, which required the installation of gas pressure reducing valves to maintain backpressure necessary to run the system. Demolition of boilers for digester 1 & 2 on hold pending completion of the gas conditioning system; Demolition of boilers for digester 3 on hold pending startup of boiler for digester 3 and gas conditioning system commissioning. Complete commissioning expected in August due to supply chain delays.
5. Gas Conditioning System: Cleans and conditions the gas to burn cleaner in the boilers to meet air quality regulations.
 - a. Status: System has been constructed, although gas pressure reducing valves must be installed for proper operation. These are long lead time items (8-12 weeks), which will delay commissioning until late-June or early-July.
6. Impure Water Pump (IPW) System: Pumps, controls and associated piping to provide consistent and reliable water pressure to the fine screens.
 - a. Status: Piping has been installed; GSE is waiting for delivery of pumps.

Engineering of the WWTP P2 Project is progressing well. Approximately \$2.3M remains in the original Parsons Engineering contract. This project is on-budget and on-schedule.

As always, feel free to contact me anytime to discuss MUED issues, programs, projects, or concerns.

John R. Harris

jharris@cityofredlands.org

(909) 725-1963

Attachments:

- A – Draft MUPWC Annual City Council Report Presentation
- B – Dudek Wastewater Master Plan
- C – MUED Organizational Chart
- D – Water Meter Replacement Project Location Map
- E – PMP Location Map
- F – CIP Project Status Worksheet

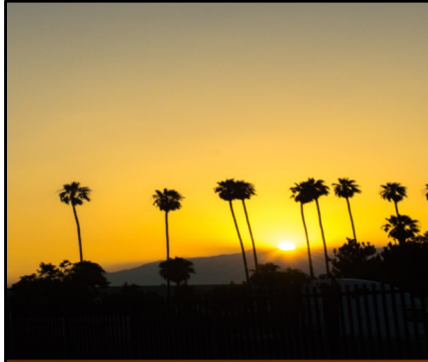

City of
Redlands

MUNICIPAL UTILITIES/PUBLIC WORKS COMMISSION ANNUAL REPORT

JUNE 7, 2022

1

Good evening Mayor and City Council.

My name is Adekunle Ojo and I am the Municipal Utilities/Public Works Commission Chairperson.

On behalf of my colleagues, I am please to present the Annual Commission Report to the City Council tonight.



Redlands Municipal Code Chapter 2.38

- A resource for City Council, staff, and buffer with the general public
- Knowledgeable of Public Works, Utilities, and Engineering Programs
- Provide advice to City Departments regarding public acceptability of proposed plans, programs, and projects including studies and proposals related to rates and fees charged to the public (water, sewer, solid waste, DIF)

2

Chapter 2.38 of the Redlands Municipal Code establishes these primary responsibilities for the Commission.

Each of the seven (7) Commissioners is appointed by the Mayor, with the approval of the City Council, to serve a four (4) year term.

The Commission elects its own Chairperson and Vice Chairperson each year, and typically meets every other month throughout the year.

We are supported by the Municipal Utilities & Engineering Department Director and staff.



MUPWC Membership

The Municipal Utilities/Public Works Commission appreciates the opportunity to be a collective resource for City Council, staff, and the entire Redlands community

Adekunle
Ojo



2018

Brad
Thoms



2018

CV



2019

David
Garcia



2020

Steve
Stockton



2018

Tom
Breitkreuz



2020

Zachary
Travis



2020

3

Commissioners are grateful to serve the Redlands community with our professional knowledge and experience.

We are Engineers, Public Works Professionals, Utilities and Environmental Specialists, and some Commissioners have served as MUED Directors in the past.

Collectively, we bring many decades of professional experience to each Commission meeting.



2021 Accomplishments

- ✓ Pavement Management Program
- ✓ WWTP Improvement Project – Phase 1B
- ✓ Water Systems & Wastewater System Master Plan Updates
- ✓ Groundwater Well & Booster Pump Rehabilitation Project
- ✓ Waterline Replacement Project
- ✓ Wastewater Replacement & Slip-Lining Projects
- ✓ Water Infrastructure Condition, Seismic, Structural Assessment
- ✓ Water System SCADA Expansion Project
- ✓ Citywide Water Meter Replacement Project

4

This has been a very busy year for the Commission, as we advised the MUED staff through the most aggressive Capital Improvement Project delivery schedule in the City's history.

This is an abbreviated list of projects that were either started or completed during the last year.

In 2021, 50 miles of streets were rehabilitated, 4 miles of waterlines were replaced, 2 miles of wastewater collection pipelines were replaced or lined, seven (7) groundwater wells were rehabilitated, the Water SCADA system was expanded, utility master plans were developed, and the first year of a five (5) year project to replace all water meters within the City's service area began.



2021 Accomplishments

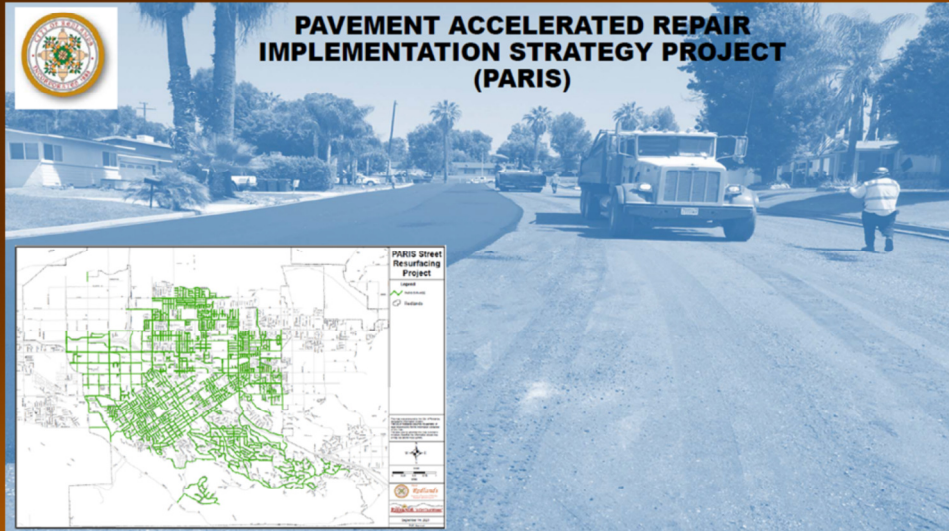

5

Last year, the Commission guided the completion of the multi-year PARIS Project, which reconstructed more than 440 lane miles of City streets and improved the Redlands pavement condition index from one of the lowest in the state, to one of the highest in the state.

The success of this project was notable enough to earn the prestigious Southern California Chapter American Public Works Association Transportation Project of the Year.

The PARIS Project is also a finalist for the National American Public Works Association Transportation Project of the Year.



2021 Accomplishments



6

Despite significant supply chain delays, Phase 1B of the WWTP Improvement Project is nearly complete, and the City secured a \$45M State Revolving Fund loan to construct Phase 2 of the project.

These are pictures of the major Phase 1B Project components. The pictures on the left and right sides of the screen are of the new fine screen system, which will protect and prolong the Membrane Bioreactor service life. The new gas conditioning system is shown in the center of the screen.

A bid notice for construction of Phase 2 will be issued in the next few months.



2021 Accomplishments



PRE-2021 METER



NEW AMI-CAPABLE
METER

7

More than half of all meters within the City's water service area are past their anticipated service life, and many no longer accurately measuring customer water use.

These failing water meters significantly increase system "water loss" and decrease water service revenue.

Replacing these meters will allow the City to recapture lost revenue, and defer the need to increase water rates in the near-future.



2022 Goals

- ✓ Complete WWTP Improvement Project – Phase 1B
- ✓ Transition to WWTP Improvement Project – Phase 2
- ✓ Implement Utility Planning Document Project Recommendations
- ✓ Continue Groundwater Well & Booster Pump Rehabilitation Project
- ✓ Pavement Management Project – 30 Miles
- ✓ Waterline Replacement Project – 4.2 Miles
- ✓ Wastewater Replacement & Slip-Lining Projects – 4.5 Miles
- ✓ Complete Water System SCADA Expansion Project
- ✓ Continue Citywide Water Meter Replacement Project

8

2022 looks to be another busy year for the Commission and MUED, as we work together to continue the successes of annually recurring paving, pipeline replacement, groundwater well and booster pump rehabilitation, and water meter replacement projects.

We are excited to begin construction of the much anticipated Phase 2 WWTP Improvement Project, and to complete the final phase of the SCADA Expansion Project.

In 2022, we will also begin implementing recommendations from the Water and Wastewater Master Plans, the Brady & Associates Condition, Seismic, and Structural Assessment, and critical safety and security improvements at our treatment plants, reservoirs, and groundwater well sites.



Thank You!

9

So, on behalf of the entire Municipal Utilities/Public Works Commission, I thank you for allowing the Commission to serve the Redlands community.

Citywide Wastewater Master Plan

Summary Report



Prepared for:

City of Redlands
35 Cajon Street
Redlands, California 92373

Prepared by:

DUDEK
605 Third Street
Encinitas, California 92024

December 2021

INTENTIONALLY LEFT BLANK

Table of Contents

SECTIONS

Acknowledgements.....	vii
Acronyms and Abbreviations.....	viii
Executive Summary.....	ix
ES-1 Key Project Objectives.....	ix
ES-2 Service Area and System Overview.....	ix
ES-3 Collection System Hydraulic Model Development and Calibration.....	xi
ES-4 Collection System Capacity Analysis Summary.....	xii
ES-5 WWTP Process Evaluation.....	xii
ES-6 CIP Recommendations.....	xiii
1 Introduction.....	1
1.1 Background and Master Plan Objectives.....	1
1.2 Previous Master Plans.....	1
1.3 Service Area Overview.....	1
1.4 Summary of Scope of Work.....	2
1.5 Report Organization.....	5
2 Existing System Description.....	7
2.1 Sewer Collection System Summary.....	7
2.2 Siphons.....	10
2.3 Diversion Manholes.....	14
2.4 Sewer Lift Stations and Force Mains.....	14
2.5 Sewer Flow Patterns.....	17
2.6 Sewer Treatment.....	17
2.7 Land Use.....	18
3 Future Flow Projections.....	21
3.1 Population Growth Projections.....	21
3.1.1 Existing Population.....	21
3.1.2 Projected Population.....	21
3.2 Projected 2030 (Near-Term) Flow Projections.....	21
3.3 Projected 2045 (Long-Term) Flow Projections.....	26
3.4 Projected 2070 (Ultimate) Flow Projections.....	26
3.5 System Flow Summary.....	26
4 Collection System Capacity Analysis.....	27

4.1 Design Criteria.....27

4.2 Pipeline Evaluation.....28

4.3 Hydraulic Model Development28

 4.3.1 Dry Weather Flow Loading29

 4.3.2 Wet Weather Flow Loading29

 4.3.3 Model Calibration29

4.4 Capacity Analysis32

 4.4.1 Existing (2020) Flow Capacity Evaluation.....32

 4.4.2 Near-Term (2030) Flows Capacity Evaluation.....37

 4.4.3 Long-Term (2045) Capacity Evaluation.....42

 4.4.4 Buildout (2070) Flows Capacity Evaluation.....46

 4.4.5 Lift Station and Forcemain Analysis.....50

 4.4.6 Capacity Analysis Summary51

5 WWTP Process Evaluation55

 5.1 Process Overview.....55

 5.1.1 Previous Studies.....57

 5.2 Summary of Regulatory Permits.....58

 5.3 Process Performance and Capacity Evaluation59

 5.3.1 Individual Unit Process Performance.....59

 5.3.2 Effective Capacity64

 5.4 72-Hour Power Outage Evaluation.....65

 5.4.1 Existing Backup Power Generators.....65

 5.4.2 Existing Protocols.....65

 5.4.3 Existing Operational Challenges.....65

 5.4.4 Mitigation Strategies66

 5.5 Potential Sites for Future WWTP Expansion66

 5.6 Cogeneration Cost-Benefit Analysis67

 5.6.1 Background on Cogeneration67

 5.6.2 Opportunity for Cogeneration at Redlands WWTP69

 5.6.3 Life-Cycle Cost Analysis Model.....70

 5.6.4 Summary and Comparison72

 5.7 WWTP Process Evaluation Conclusions and Recommendations.....73

6 Recommendations.....75

 6.1 Pipeline Capacity Improvement Recommendations75

 6.2 Lift Station Operations Recommendations.....87

 6.3 WWTP Process Recommendations.....87

 6.4 Project Cost Summary87

TABLES

Table ES.1: Existing and Projected Sewer Flows.....	xi
Table ES.2: Sewer Hydraulic Model Calibration Results	xii
Table ES.3: Redlands WWTP Effective Capacity	xiii
Table ES.4: Project Cost Summary.....	xv
Table 2.1: Gravity Pipeline Summary by Diameter, Material and Length ¹	8
Table 2.2: Gravity Pipeline by Age	8
Table 2.3: Existing Sewer Siphons	10
Table 2.4: Existing Diversion Manholes (10-inch pipe and larger)	14
Table 2.5: City-Owned Sewer Lift Station Data.....	14
Table 2.6: Land Use Summary	18
Table 3.1: Existing and Projected Population	21
Table 3.2: Unit Sewage Flow Factors.....	24
Table 3.3: Additional Loads from Near-Term Developments	24
Table 3.4: Transit Villages Unit Sewage Flow Factors ¹	25
Table 3.5: Transit Villages Specific Plan Development	25
Table 4.1: Design and Evaluation Criteria.....	27
Table 4.2: Sewer Hydraulic Model Calibration Results	29
Table 4.3: Recommended Existing (2020) System Capacity Improvements	32
Table 4.4: Recommended Near-Term (2030) System Capacity Improvements	37
Table 4.5: Recommended Long-Term (2045) System Capacity Improvements	42
Table 4.6: Recommended Buildout (2070) System Capacity Improvements	46
Table 4.7: PWWF San Bernardino/Mountain View Lift Station Capacity Analysis	50
Table 4.8: ADWF San Bernardino/Mountain View Wet Well Capacity Analysis.....	51
Table 4.9: Existing and Projected Sewer Flows.....	51
Table 4.10: Summary of Recommended System Capacity Improvements (All Phases).....	52
Table 5.1: Summary of Previous Report	57
Table 5.2: Conventional and Recycled Water Effluent Discharge Requirements	58
Table 5.3: Mountainview Power Company Discharge Requirements.....	59
Table 5.4: Redlands WWTP Process Performance Summary	60
Table 5.5: Redlands WWTP Operating Parameters.....	62
Table 5.6: Redlands WWTP Effective Capacity.....	64
Table 5.7: CHP Engine Types and Specifications.....	68
Table 5.8: Lifecycle Cost Model Inputs.....	70
Table 5.9: O&M Cost Estimate for Existing Conditions	70
Table 5.10: Capital Cost Estimates.....	71
Table 5.11: O&M Cost Estimate for 75% operation	72

Table 5.12: O&M Cost Estimate for 90% operation72

Table 5.13: Comparison of major cost items between existing and proposed upgrades over 20 years73

Table 6.1: Recommended Pipeline Capacity Projects75

Table 6.2: Lift Station Recommendations87

Table 6.3: WWTP Process Recommendations87

Table 6.4: Project Cost Summary.....88

FIGURES

Figure 1.1: Regional Map 3

Figure 1.2: Service Area Boundary..... 4

Figure 2.1: Sewer Collection System 9

Figure 2.2: Orange Blossom Trail and Morey Arroyo Creek Siphons.....11

Figure 2.3: Domestic Ave West End Siphon12

Figure 2.4: Mountain View Ave at Lugonia Ave Siphon.....13

Figure 2.5: Sewer Lift Station Location Map15

Figure 2.6: WWTP Influent Flow 24-Hour Dry Weather (August 7-8, 2020) and Wet Weather (March 12, 2020) Diurnal Curves.....17

Figure 2.7: Land Use within Sewer Service Area.....19

Figure 3.1: Near-Term Developments Location Map22

Figure 3.2: Near-Term Developments Location Map (Downtown Redlands Area)23

Figure 4.1: 24-Hour WWTP Dry Weather Calibration.....30

Figure 4.2: 24-Hour WWTP Wet Weather Calibration.....31

Figure 4.3: Results of Existing (2020) PWWF Capacity Evaluation33

Figure 4.4: Cajon St (Between Cypress Ave and Fern Ave) Capacity Evaluation.....34

Figure 4.5: Cajon St (South of E Citrus Ave) Capacity Evaluation35

Figure 4.6: Alley East of Alabama St (Between San Bernardino Ave and Palmetto Ave) Capacity Evaluation ...36

Figure 4.7: Results of Near-Term (2030) Capacity Evaluation with 2020 Improvements.....38

Figure 4.8: Brockton Ave at 6th St Capacity Evaluation.....39

Figure 4.9: Citrus Plaza Dr (South of San Bernardino Ave) Capacity Evaluation.....40

Figure 4.10: Nevada St (North of Palmetto Ave) Capacity Evaluation41

Figure 4.11: Results of Long-Term (2045) Capacity Evaluation with 2020 and 2030 Improvements43

Figure 4.12: South Ave (Between Garden St and Franklin Ave) Capacity Evaluation.....44

Figure 4.13: Cajon St (Between 600 feet North of Highland Ave and Cypress Ave) Capacity Evaluation45

Figure 4.14: Results of Buildout (2070) Capacity Evaluation with 2020, 2030, and 2045 Improvements47

Figure 4.15: South Ave at Franklin Ave Capacity Evaluation.....48

Figure 4.16: Cajon St at Vine St Capacity Evaluation49

Figure 4.17: Recommended Capacity Improvements (All Phases).....53

Figure 5.1: Liquids Process Flow Diagram56

Figure 5.2: Solids Process Flow Diagram.....56

Figure 5.3: Existing WWTP Site Layout.....57

Figure 5.4: Potential Areas of Expansion67

Figure 5.5: Typical Process Flow Diagram for Cogeneration.....69

Figure 6.1: Recommended Pipeline Improvements.....76

Figure 6.2: Results of Cajon St (Between Cypress Ave and Fern Ave) Capacity Improvement Under Existing (2020) Conditions, Sized for Buildout (2070) Conditions77

Figure 6.3: Results of Cajon St (South of E Citrus Ave) Capacity Improvement Under Existing (2020) Conditions, Sized for Buildout (2070) Conditions78

Figure 6.4: Results of Alley East of Alabama St (Between San Bernardino Ave and Palmetto Ave) Capacity Improvement Under Existing (2020) Conditions, Sized for Buildout (2070) Conditions79

Figure 6.5: Results of Brockton Ave at 6th St Capacity Improvement Under Near-Term (2030 Conditions), Sized for Buildout (2070) Conditions.....80

Figure 6.6: Results of Citrus Plaza Dr (South of San Bernardino Ave) Capacity Improvement Under Near-Term (2030 Conditions), Sized for Buildout (2070) Conditions81

Figure 6.7: Results of Nevada St (North of Palmetto Ave) Capacity Improvement Under Near-Term (2030 Conditions), Sized for Buildout (2070) Conditions82

Figure 6.8: Results of South Ave (Between Garden St and Franklin Ave) Capacity Improvement Under Long-Term (2045) Conditions, Sized for Buildout (2070) Conditions83

Figure 6.9: Results of Cajon St (Between 600 feet North of Highland Ave and Cypress Ave) Capacity Improvement Under Long-Term (2045) Conditions, Sized for Buildout (2070) Conditions.....84

Figure 6.10: Results of South Ave Capacity Improvement Under Buildout (2070) Conditions.....85

Figure 6.11: Results of Cajon St (North of Vine St) Capacity Improvement Under Buildout (2070) Conditions.86

APPENDICES

- A. Near-Term Developments
- B. 2021 SOP Plant Power Outage
- C. Cogeneration Pre-Cleaning Technologies
- D. Cogeneration Unit Cut Sheet
- E. Project Cost Summary Detail

INTENTIONALLY LEFT BLANK

Acknowledgements

We appreciate the combined efforts of the entire project team in the development and preparation of the sewer master plan. Our project team includes staff from the City and Dudek. The efforts of the following individuals are respectfully and gratefully acknowledged for their contributions to the completion of the evaluations presented in this report:

City of Redlands

Veronica Medina, EIT, Project Manager

John Harris, MUED Director

Goutam Dobey, P.E., Engineering Manager

Kevin Watson, Utilities Operations Manager

Fernando Mata, Wastewater Superintendent

James Estrada, Wastewater Collections Supervisor

Dudek

Russ Bergholz, PE, Principal-in-Charge

Elizabeth Caliva, PE, Project Manager

Phil Giori, PE, Senior Engineer

Artin Oroujian, PE, Senior Engineer

Hanna Dodd, PE, Project Engineer

Shannon Brown, PE, Project Engineer

Jenny Li, EIT, Project Engineer

Agata Bugala EIT, Project Engineer

Acronyms and Abbreviations

afy	acre-feet per year	in-diam	inner diameter
ac	acre	kWh	kilowatt-hour
ADWF	average dry weather flow	LF	Lineal feet
AQMD	Air Quality Management District	LTSA	long term service agreement
AWWF	average wet weather flow	MBR	membrane bioreactor
BOD	biological oxygen demand	MGD	million gallons per day
CAS	conventional activated sludge	O&M	operations and maintenance
CEM	continued emissions monitoring	OPH	operation hour
CHP	combined heat and power	PDWF	peak dry weather flow
CIP	Capital Improvement Program	PLC	Programmable Logic Controller
City	City of Redlands	PS	pump station
cu. ft	cubic ft (ft ³)	PVC	polyvinyl chloride
d/D	Depth to Diameter ratio	PWWF	peak wet weather flow
DAFT	dissolved air flotation tanks	RCP	reinforced concrete pipe
du or DU	dwelling unit	SCADA	supervisory control and data acquisition
D/S	downstream	SCAQMD	South Coast Air Quality Management District
EPS	extended period simulation	SCR	selective catalytic reduction
EQ	equalization	SMP	Sewer Master Plan
FOG	fats, oils, and grease	SOP	standard operating procedure
ft	feet	SSO	sanitary sewer overflow
GIS	Geographic Information System	TBD	to be determined
gpd	gallons per day	UNK	unknown
gpd/acre	gallons per day per acre	UPS	Uninterrupted Power Supply
gpd/DU	gallons per day per dwelling unit	U/S	upstream
H ₂ S	hydrogen sulfide	VCP	vitricified clay pipe
HDR	high density residential	VS	volatile solids
HMI	Human Machine Interface	VSS	volatile suspended solids
HRT	hydraulic retention time	WDR	Waste Discharge Requirements
i.e.	that is	WWTP	Wastewater Treatment Plant
I/I	inflow and infiltration		

Executive Summary

This Executive Summary provides highlights from the following Citywide Wastewater Master Plan report, summarizing the key findings and recommendations of each section. The Executive Summary consists of the following sections:

- Key Project Objectives
- Service Area and System Overview
- Future Flow Projections
- Collection System Hydraulic Model Development and Calibration
- Collection System Capacity Analysis Summary
- Wastewater Treatment Plant (WWTP) Process Evaluation
- Capital Improvement Program (CIP) Recommendations

ES-1 Key Project Objectives

In September 2020, the City of Redlands (City) retained Dudek to prepare the City's citywide wastewater collection system master plan. The goal of this project was to develop a clear understanding of the sewer collection system needs, both existing and future, and establish a management plan that supports those needs.

This 2021 Citywide Wastewater Master Plan seeks to address the following key objectives:

- Construct a new collection system hydraulic model based on current flow and wastewater facilities data and confirm existing and future dry and wet weather capacity.
- Perform a capacity analysis and high-level process evaluation on the City's wastewater treatment plant.
- Develop project costs and prioritization of recommended capital improvement projects.

ES-2 Service Area and System Overview

The City of Redlands sewer service area covers approximately 48 square miles and is located 60 miles east of Los Angeles within San Bernardino County in Southern California. The City provides wastewater collection service to most parcels within the City limits through approximately 245 miles of gravity sanitary sewer pipelines, and one City-owned lift station, as shown in **Figure ES.1**.

All sewage generated within the service area is ultimately conveyed to the City's 9.5 million gallons per day (MGD) wastewater treatment plant. The WWTP currently operates two parallel treatment systems, a membrane bioreactor (MBR) treatment process with the capability to produce up to 6.0-MGD of recycled water and a conventional process with a capacity of 3.5-MGD.

More than a third of the land within the sewer service area is open space/recreation (36%) and more than a quarter is single family residential (26%). After residential and open space/recreation, a large portion of the land use is public/institutional (18%) and the remaining 20% is made up of agricultural (8%), industrial (6%), commercial (3%) and multi-family residential (2%).

Figure ES.1: Sewer Collection System

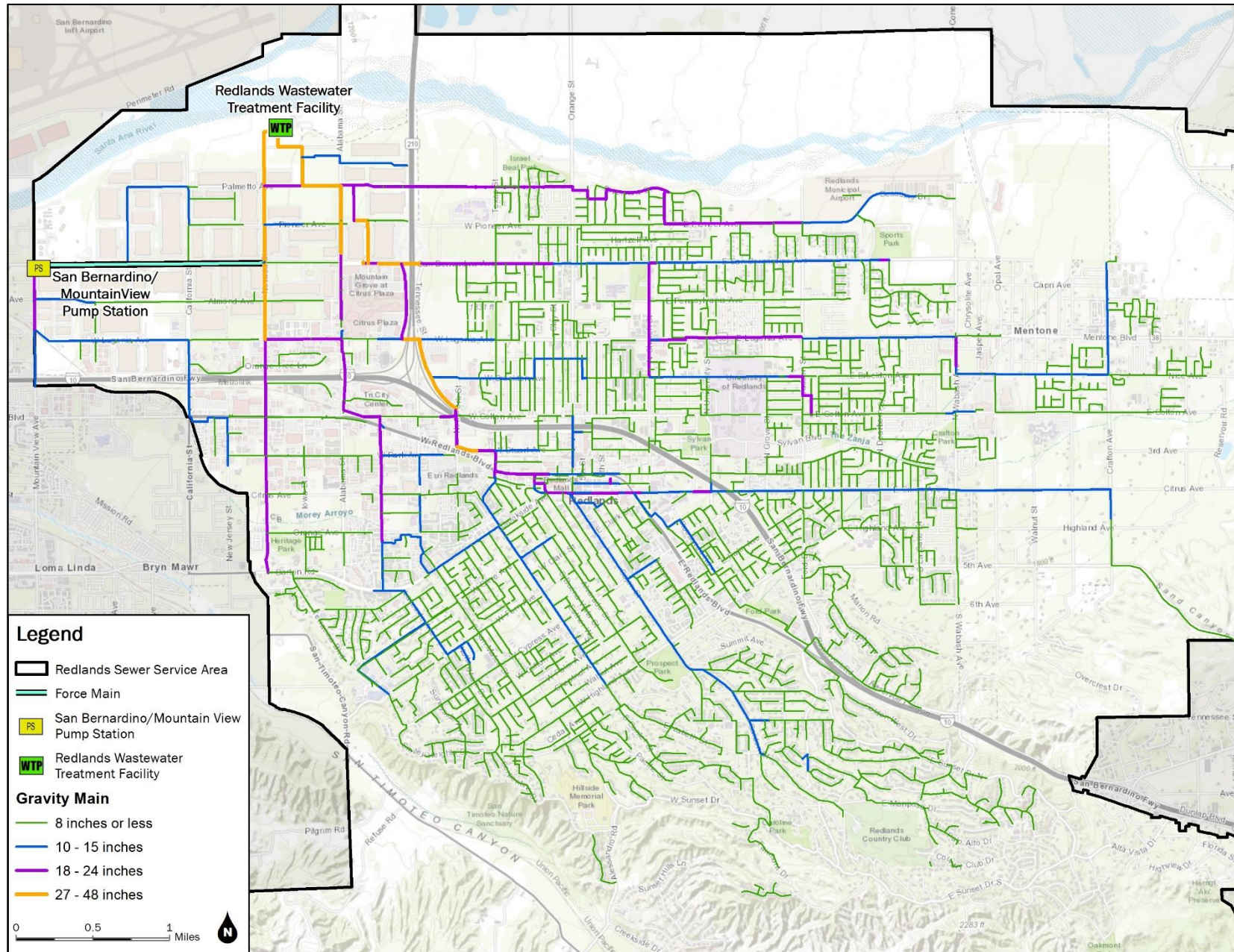

ES-3 Future Flow Projections

The City's 2019 population of approximately 72,200 is expected to grow to a buildout population of 90,000 by 2070. This City-wide population growth, combined with 1.1 MGD of additional flows from 55 developments currently planned to be built between 2020 and 2030, produces the estimated total average dry weather flows (ADWFs) and total average wet weather flows (AWWFs) for the City's collection system found in **Table ES.1**.

Table ES.1: Existing and Projected Sewer Flows

Year	ADWF (MGD)	PDWF (MGD)	AWWF (MGD)	PWWF (MGD)
2020	5.8	8.1	6.5	12.0
2030	6.9	10.4	7.6	12.9
2045	7.7	10.9	8.4	14.2
2070	8.0	11.6	8.7	15.0

ES-4 Collection System Hydraulic Model Development and Calibration

Available City GIS data for sewer pipelines 10-inches or greater in diameter (plus approximately 13,000 LF or 2.5 miles of 8-inch pipe) were used to develop and Innovyze® InfoSewer® model of the system. To load the model's dry weather scenarios, ADWFs measured at the WWTP in August 2020 were distributed proportionately through the existing system based on water usage data from the City's water billing database for calendar years 2017, 2018 and 2019. Similarly, wet weather flows measured at the WWTP on March 12, 2020 were used to distribute loads in the model's wet weather scenarios.

Once developed, the sewer model was calibrated. Model calibration is a process to ensure model outputs, including average flows, peak flows, and diurnal flow patterns, are consistent with field measured data. Sewer flow monitoring, while commonly used to assist with model calibration, was not performed due to time, and cost limitations. Hourly flow measurements entering the WWTP were exclusively utilized for developing the flow loading of model nodes. The hydraulic model is considered calibrated when both hourly flows and 24-hour flows were within 10% of field measurements. The results of the model calibration are presented in **Table ES.2**.

Table ES.2: Sewer Hydraulic Model Calibration Results

2020	WWTP Field Measured Flow (MGD)	WWTP Modeled Flow (MGD)	Percentage Difference
ADWF	5.8 ¹	5.8	0%
PDWF	8.1 ²	8.1	0%
AWWF	6.4 ³	6.5	2%
PWWF	12.0 ⁴	12.1	1%

Notes:

¹ Based on average flows measured from August 1 through August 31, 2020.

² Value based on average of daily peak flows measured from August 1 through August 31, 2020.

³ Value based on average flows measured on March 12, 2020 wet weather day.

⁴ Actual measured PWWF on March 12, 2020 was 10 MGD due to limitations of the WWTP influent flow meter, though flow trajectories implied this value was higher. With concurrence with City staff, a value of 12 MGD was used to calibrate the hydraulic model for PWWF.

ES-5 Collection System Capacity Analysis Summary

The capacity of a sewer collection system is typically evaluated under peak wet weather flow (PWWF) conditions when flows are the highest. The calibrated hydraulic model developed for this project was used to evaluate system capacity under PWWF for existing (2020). Anticipated future flow scenarios (2030, 2045 and 2070) were loaded based on the results of the future flow projections analysis and then evaluated for system capacity. Collection system capacity was evaluated by determining the maximum depth over diameter (d/D) values in the system estimated during peak flows. The existing and future capacity analyses resulted in approximately 10,500 linear feet (LF) of pipeline being identified for improvement based on a d/D trigger criterion of 1.0 (100% full flow) under anticipated PWWF conditions. Recommended upsizing of pipelines are based on meeting pipeline design criteria under anticipated ultimate (2070) PWWF conditions.

In addition to evaluating pipeline capacity, the capacity of the lift station and wet well were also evaluated. Based on projected sewer inflow rates and with the largest pump out of service, the San Bernardino/Mountain View lift station is capable of handling PWWF throughout buildout of the system. When the pump in the San Bernardino/Mountain View lift station is in operation, the existing 12-inch and 14-inch forcemain velocities fall within the range allow by this master plan’s design criteria, or between a minimum 2.5 feet per second (fps) and a maximum of 8 fps.

The existing wet well of the San Bernardino/Mountain View lift station does not meet the design criteria for emergency storage of 6 hours of ADWF. However, in the event of a power outage, there is an existing overflow discharge pipe that will take excess sewage flow by gravity from the San Bernardino/Mountain View lift station to the San Bernardino Wastewater Facility. The wet well currently provides approximately 2.5 hours of emergency storage. As development continues, that storage duration is projected to drop to approximately 1.5 hours in 2045.

ES-6 WWTP Process Evaluation

For this master plan, a high-level WWTP treatment processes evaluation was performed with a focus on near-term, long-term and buildout capacity. Individual unit process capacities were evaluated under current loading conditions as well as anticipated future loadings (2030, 2045, 2070). Results from the evaluation are intended to assist the City to determine potential near-term, long-term, and buildout upgrade needs and operations & maintenance (O&M) considerations for the WWTP. Unit process capacities normalized to average daily influent flow are summarized in **Table ES.3**.

Table ES.3: Redlands WWTP Effective Capacity

Unit Process	Avg. Flow Projections (MGD)				
	ADF Permitted Capacity	Current (2019-2020)	Near-Term (2030)	Long-Term (2045)	Buildout (2070)
Headworks	9.5	6	7	7.8	8.1
Raw Sewage PS	9.5	6	7	7.8	8.1
Primary Clarifiers	9.5	6	7	7.8	8.1
Peak Ponds (Flow Equalization)	9.5	6	7	7.8	8.1
Aeration Basins (CAS)	3.5	3.25	3.25	3.25	3.25
Aeration Basins (MBR)	6	2.8	3.8	4.6	4.9
Fine Screens (not existing)	-	-	-	-	-
MBR System	6	2.8	3.6	4.4	4.8
Chlorine Contact Tanks	6.6	2.8	3.6	4.4	4.8
Recycled Water PS	6.6	1.8	-	-	-
Effluent PS	9.5	6	7	7.8	8.1
Percolation Ponds (TBD)	-	-	-	-	-
DAF Thickeners	9.5	-	7	7.8	8.1
Digesters	9.2	-	7	7.8	8.1
Centrate Management (TBD)	-	-	-	-	-
Centrifuges (TBD)	-	-	-	-	-
Digester Gas Facilities (TBD)	-	-	-	-	-

The analysis found that the present treatment system is sufficient to meet projected demands in the near-term, long-term, and ultimate buildout. Solids treatment capacity and performance requires additional evaluation to address changes to influent loading concentrations and/or if the City pursues energy resource recovery through acceptance of food waste and/or FOG in conjunction with digester gas cogeneration and/or treatment and sale. A high-level cost estimate suggests that a cogeneration system would conservatively have a payback period between 11 and 16 years and save the City between \$1 to \$3 million over its 20-year useful life, before accounting for waste heat recovery. A cogeneration system would help the City reduce greenhouse gas (GHG) and other air quality emissions while saving on electricity costs.

The property size of the WWTP is large enough to accommodate the phased replacement and upgrade of facilities over time without causing significant constructability or maintenance of plant operations issues. A large portion of the plant site is used for sludge drying beds, which can be removed and replaced with mechanical dewatering and sludge cake storage if necessary. In addition, when the secondary clarifiers are abandoned in lieu of a full process conversion to membrane bioreactors (MBR), this portion of the site can be utilized for additional solids handling and/or gas handling facilities.

ES-7 CIP Recommendations

Capital Improvement Plan (CIP) projects were identified for pipelines, the San Bernardino/Mountain View Lift Station, and the WWTP.

A total of 10 pipeline improvements were identified, shown graphically in **Figure ES.2**. Due to the capacity analysis being based on a hydraulic model calibrated on only the WWTP influent flow meter, it is recommended that system-wide flow monitoring (CIP Project P-0) be performed prior to commencing each improvement. The system-wide flow monitoring should ensure a flow meter at each of the recommended pipeline improvement locations noted below.

It is recommended the City conduct an Optimization Study on the San Bernardino/Mountain View Lift Station to determine if there are opportunities to optimize operations to reduce power costs.

Figure ES.2: Recommended Pipeline Improvement Projects

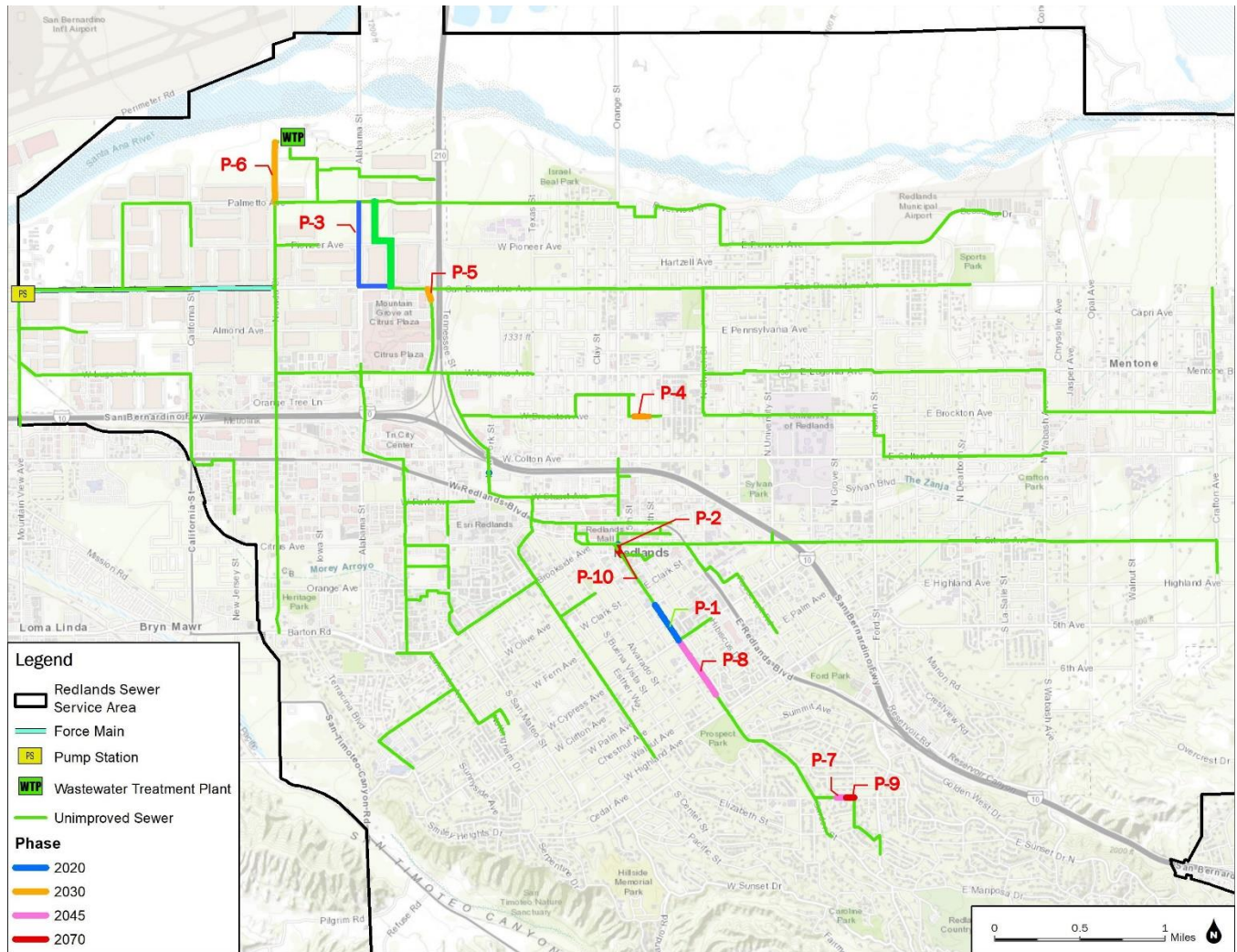

It is recommended that the City develop a Solids Management Plan (Project WWTP-01) in the event the City elects to receive food waste, fats, oils and grease (FOG), and/or if solids loads to the WWTP increase. Additionally, it is recommended the City to consider replacing the existing, not-in-use cogeneration system with a new modern system (Project WWTP-02), as this could reduce electricity usage rates by utilizing WWTP produced biogas. A new, optimized cogeneration system can also significantly reduce air pollution levels from the plant as biogas wouldn't be directly flared off to the atmosphere and would function as a reliable source for any heating process within the WWTP. Project costs for the preliminary design of this new modern Cogeneration Facility and other CIP projects are listed in **Table ES.4**.

Table ES.4: Project Cost Summary

Project ID	Project Name	Description	Justification	Project Costs by Planning Period (\$)			
				Existing (2020)	Near-Term (2030)	Long-Term (2045)	Buildout (2070)
Gravity Sewer Projects							
P-0	System-Wide Flow Monitoring	Install thirty (30) flow meters throughout existing sewer system	Confirm the need for each improvement based on real-time flow monitoring data	\$ 162,000	-	-	-
P-1	Cajon St, Cypress Ave to Fern Ave, Pipeline Upsizing	Upsize 1,350 LF of 10-inch to 12-inch	Max d/D is 1.0 under 2020 PWWF	\$ 827,000	-	-	-
P-2	Cajon St at Citrus Ave Pipeline Upsizing	Upsize 100 LF of 12-inch to 15-inch	Max d/D is 1.0 under 2020 PWWF	\$ 141,000	-	-	-
P-3	Alabama St Pipeline Upsizing and Realignment	Install concrete plug to abandon 3,100 LF of existing 24-inch and 30-inch; Build 920 LF of new 24-inch in San Bernardino Ave; Build 2,700 LF of 36-inch in Alabama St	Max d/D is 1.0 under 2020 PWWF	\$ 4,967,000	-	-	-
P-4	Brockton Ave Pipeline Upsizing	Upsize 700 LF of 8-inch to 10-inch	Max d/D is 1.0 under 2030 PWWF	-	\$ 445,000	-	-
P-5	Citrus Plaza Dr Pipeline Upsizing	Upsize 350 LF of 24-inch to 27-inch	Max d/D is 1.0 under 2030 PWWF	-	\$ 671,000	-	-
P-6	Nevada St Pipeline Upsizing	Upsize 1,900 LF of 27-inch to 30-inch	Max d/D is 1.0 under 2030 PWWF	-	\$ 2,452,000	-	-
P-7	South Ave West of Franklin Ave Pipeline Upsizing	Upsize 300 LF of 8-inch to 10-inch	Max d/D is 1.0 under 2045 PWWF	-	-	\$ 233,000	-
P-8	Cajon St between Highland Ave and Cypress Ave Pipeline Upsizing	Upsize 2,180 LF of 10-inch to 12-inch	Max d/D is 1.0 under 2045 PWWF	-	-	\$ 1,136,000	-
P-9	South Ave at Franklin Ave Pipeline Upsizing	Upsize 300 LF of 8-inch to 10-inch	Max d/D is 1.0 under Buildout PWWF	-	-	-	\$ 233,000
P-10	Cajon St at Vine St Pipeline Upsizing	Upsize 300 LF of 12-inch to 15-inch	Max d/D is 1.0 under Buildout PWWF	-	-	-	\$ 346,000
Total Gravity Sewer Projects:				\$ 6,097,000	\$ 3,568,000	\$ 1,369,000	\$ 579,000
Lift Station Projects							
LS-1	San Bernardino/Mountain View LS Optimization Study	Conduct study to evaluation optimization of the MVLS	Pumps consistently operating at reduced speeds	\$ 40,000	-	-	-
Total Lift Station Projects:				\$ 40,000	\$ -	\$ -	\$ -
Wastewater Treatment Plant Projects							
WWTP-1	Solids Management Plan	Determine present solid loads and solids handling capacity at the plant.	Needed in the event the City elects to receive food waste, FOG and/or if solids loads to the plant increase.	\$ 150,000			
WWTP-2	Cogeneration Facility Preliminary Design	Preliminary design of new cogeneration facility for the WWTP.	Estimated 11 year payback period for construction of new Cogen facility.	\$ 300,000			
Total WWTP Projects:				\$ 450,000	0	0	0
TOTAL:				\$ 6,587,000	\$ 3,568,000	\$ 1,369,000	\$ 579,000

INTENTIONALLY LEFT BLANK

1 Introduction

This Wastewater Master Plan report for the City of Redlands (City) evaluates the operation and capacity of the existing wastewater collection system and wastewater treatment plant within the City of Redlands and makes recommendations for future system improvements. The report was prepared by Dudek. This introductory section provides background information on the scope and objectives of the Master Plan report, the City sewer system and services area, and the contents and organization of the report.

1.1 Background and Master Plan Objectives

In September 2020, the City retained Dudek to prepare the City's first wastewater master plan in over two decades. The City's sewer master plan was updated in 1998. Prior to 1998, the last master plan had been completed in 1972. As part of the 1998 master plan, the City had a computerized hydraulic model of the collection system prepared in conjunction with a geodatabase (GIS) of the infrastructure.

This 2021 Citywide Wastewater Master Plan update seeks to address the following key objectives:

- Construct a new collection system hydraulic model based on current flow and wastewater facilities data and confirm existing and future dry and wet weather capacity.
- Perform a high-level capacity analysis and process evaluation on the City's wastewater treatment plant.
- Develop project costs and prioritize recommended capital improvement projects.

1.2 Previous Master Plans

The primary objective of the 1998 Wastewater Collection System Master Plan was to identify collection system improvements and extensions that would be required within the planning period of 1996 to 2030. Additionally, the 1998 Master Plan converted the City's wastewater collection system maps to a GIS database to facilitate creation of a new hydraulic model of the primary (trunk) sewers. Analysis of the existing (1996) and buildout (2030) land use databases led to a projection that the potential sewer drainage area would more than triple from 9,160 acres in 1996 to 29,400 acres in 2030. The 1998 Master Plan ultimately recommended 14 primary sewer improvement projects totaling 26,500 lineal feet (LF) designed to correct hydraulically deficient pipes in the existing system. None of these projects had been implemented at the time of writing this report. To further accommodate the City's anticipated growth, the 1998 Master Plan also identified three primary sewer extensions: (1) San Timoteo/Live Oak Canyons Extension, (2) East Valley Corridor Extension, and (3) Eastern Mentone Extension; totaling approximately 37,940 ft of new sewer mains ranging from 12-inch to 18-inch in diameter. Like the primary sewer improvement projects, no sewer extension projects had been undertaken at the time of writing this report.

1.3 Service Area Overview

The City of Redlands was incorporated in 1888. A map of the region is presented in **Figure 1.1**. The current (2019) population of the City is approximately 72,200. Sewer system collection and treatment operation and maintenance is provided by the City Municipal Utilities and Engineering Department.

The City of Redlands sewer service area covers approximately 48 square miles and is located 60 miles east of Los Angeles in Southern California. The City is surrounded by several other Cities and unincorporated areas of San

Bernardino County, as shown in **Figure 1.2**. Average annual precipitation is 14 inches and most rainfall occurs between December and March.

The City of Redlands provides wastewater collection service to most parcels within the City limits through approximately 245 miles of gravity sanitary sewer pipelines. The City's wastewater collection system conveys untreated wastewater to their existing 9.5-MGD wastewater treatment plant. The wastewater treatment plant (WWTP) currently operates two parallel treatment systems, a membrane bioreactor treatment process with the capability to produce up to 6.0-MGD of recycled water and a conventional process with a capacity of 3.5-MGD.

1.4 Summary of Scope of Work

The following are primary tasks completed as part of the research, analysis, assessment and preparation of the master plan.

- Data Collection and Review
- Model Development, Calibration and Capacity Analysis
- WWTP Process Evaluation
- Recommended CIP Projects
- Wastewater Master Plan Report

Figure 1.1: Regional Map

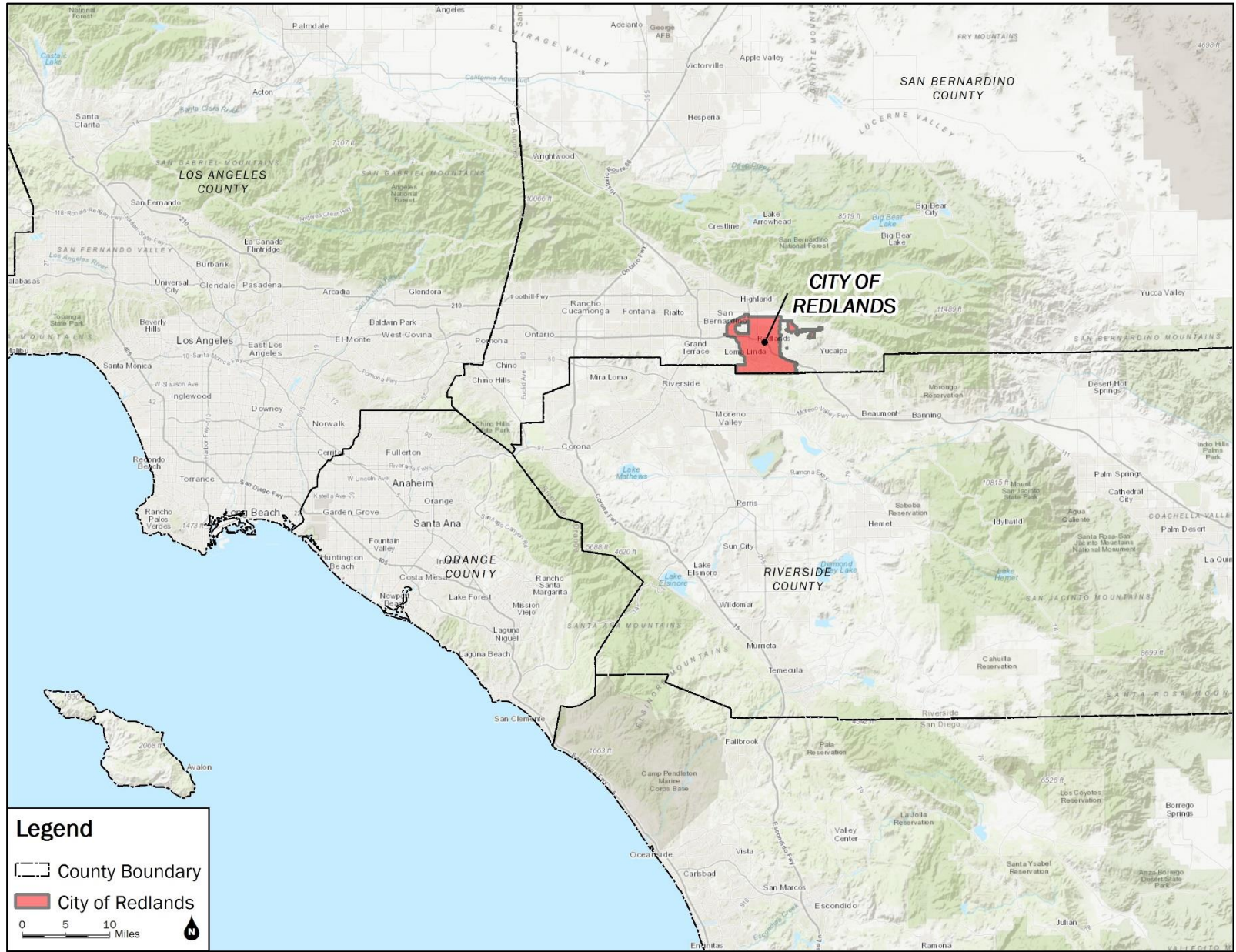
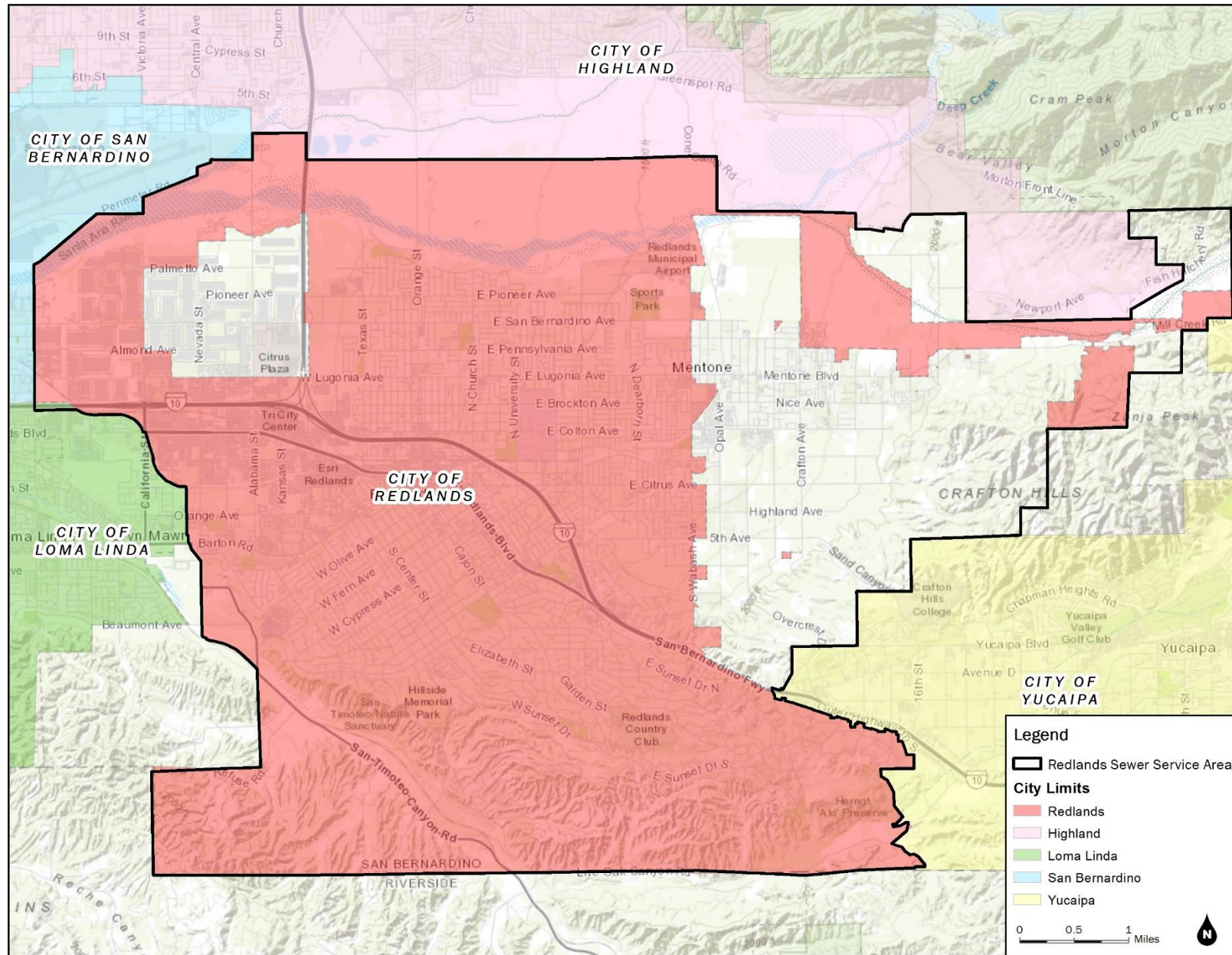

Figure 1.2: Service Area Boundary



1.5 Report Organization

The following list summarizes sections included in this report.

- **1.0 – Introduction** describes the Master Plan Update background, objectives, scope of work, and report organization, key characteristics of the collection system, WWTP, and service area.
- **2.0 – Existing System Description** summarizes the existing land use and current collection system infrastructure elements. Also included is a summary of the WWTP and WWTP inflow patterns used to calibrate the hydraulic model.
- **3.0 – Future Flow Projections** summarizes anticipated growth in the sewer service area and the sewer loadings used in the future capacity analysis scenarios.
- **4.0 – Collection System Capacity Analysis** describes the process for development and calibration of the sewer model as well as the results of the existing and future system capacity analysis.
- **5.0 – Wastewater Treatment Plant Process Evaluation** provides a high-level evaluation of WWTP unit processes under existing, near-, mid-, and long-term capacity projections. A 72-hr power outage evaluation was performed to assess deficiencies in WWTP infrastructure and operational strategies. In addition, a cost benefit analysis for cogeneration of heat and power from digester and landfill gas is presented to assess the viability of the system.
- **6.0 – Recommendations** provides a summary of the recommended system improvements identified in the collection system capacity analysis and the WWTP process evaluation.

Included as Appendices to the report are the following supporting materials.

- A. Near-Term Developments
- B. 2021 SOP Plant Power Outage
- C. Cogen Pre-Cleaning Technologies
- D. Cogen Unit Cut Sheet
- E. Project Cost Summary Detail

INTENTIONALLY LEFT BLANK

2 Existing System Description

This section summarizes facilities of the City of Redlands wastewater collection system. These facilities include gravity collection sewers, one City-owned lift station and associated force main, and a wastewater treatment plant. Information regarding the existing wastewater collection system facilities was obtained from the City's sewer system Geographic Information System (GIS), previous reports and City staff input.

The following section provides information on the following elements of the existing system:

- Sewer Collection System Summary
- Siphons
- Diversion Manholes
- Sewer Lift Stations and Force mains
- Sewer Flow Patterns
- Sewer Treatment
- Land Use

2.1 Sewer Collection System Summary

The existing sewer collection system is comprised of approximately 245 miles of gravity sewer pipelines with pipe diameters ranging from 3- to 48-inch, as detailed in **Table 2.1**. The majority (80%) of the pipes are 8-inches in diameter or smaller. Approximately 82% of the system is made up of vitrified clay pipe (VCP) with approximately 16% being polyvinyl chloride (PVC). The pipes range in age from 2 to approximately 120 years old (i.e. 1902 installation date) with approximately 34% of pipelines being over 50 years old, as presented in **Table 2.2**. All flows generated within the City are conveyed to the City's existing 9.5-MGD wastewater treatment plant for treatment and disposal. **Figure 2.1** summarizes the existing sewer collection system infrastructure.

Table 2.1: Gravity Pipeline Summary by Diameter, Material and Length¹

Diameter (inches)	Length of Pipe (ft) ²						% of Total
	VCP	Concrete/RCP	CIP/DIP	PVC	Other ³	Total	
3	200	-	-	-	-	200	0.0%
4	1,912	-	-	-	531	2,443	0.2%
6	31,799	-	-	379	-	32,179	2.5%
8	793,914	-	5,042	188,993	12,394	1,000,342	77.3%
10	34,022	1,150	663	342	52	36,230	2.8%
12	54,625	-	1,627	4,582	1,318	62,153	4.8%
14	633	-	33	-	3	669	0.1%
15	46,465	-	-	10,234	10	56,709	4.4%
18	43,000	-	205	2,646	671	46,523	3.6%
20	2,726	-	-	-	664	3,389	0.3%
21	14,082	-	-	-	-	14,082	1.1%
24	16,792	-	357	-	-	17,150	1.3%
27	2,177	-	-	-	2,338	4,515	0.3%
30	9,359	-	1,471	1,691	1,324	13,844	1.1%
36	130	-	-	1,932	-	2,063	0.2%
48	-	1,361	-	-	-	1,361	0.1%
Totals	1,051,837	2,511	9,399	210,800	19,304	1,293,850	100%
% of Total	81.3%	0.2%	0.7%	16.3%	1.5%	100%	-

Notes:

¹ Summary of data from GIS provided by City in 2020 for this study.

² Material type definitions include vitrified clay pipe (VCP), reinforced concrete pipe (RCP), cast iron pipe (CIP), ductile iron pipe (DIP) and plastic/polyvinyl chloride (PVC).

³ Other pipeline materials include asphalt concrete, elastometric-coated steel, truss and unknown.

Table 2.2: Gravity Pipeline by Age

Install Year	Length of Pipe (ft)	% of Total
Unknown	3,034	0.2%
1902-1949	70,661	5.5%
1950-1959	161,492	12.5%
1960-1969	202,744	15.7%
1970-1979	276,124	21.3%
1980-1989	247,100	19.1%
1990-1999	118,627	9.2%
2000-2009	166,417	12.9%
2010-2019	47,651	3.7%
Total	1,293,850	100%

Figure 2.1: Sewer Collection System

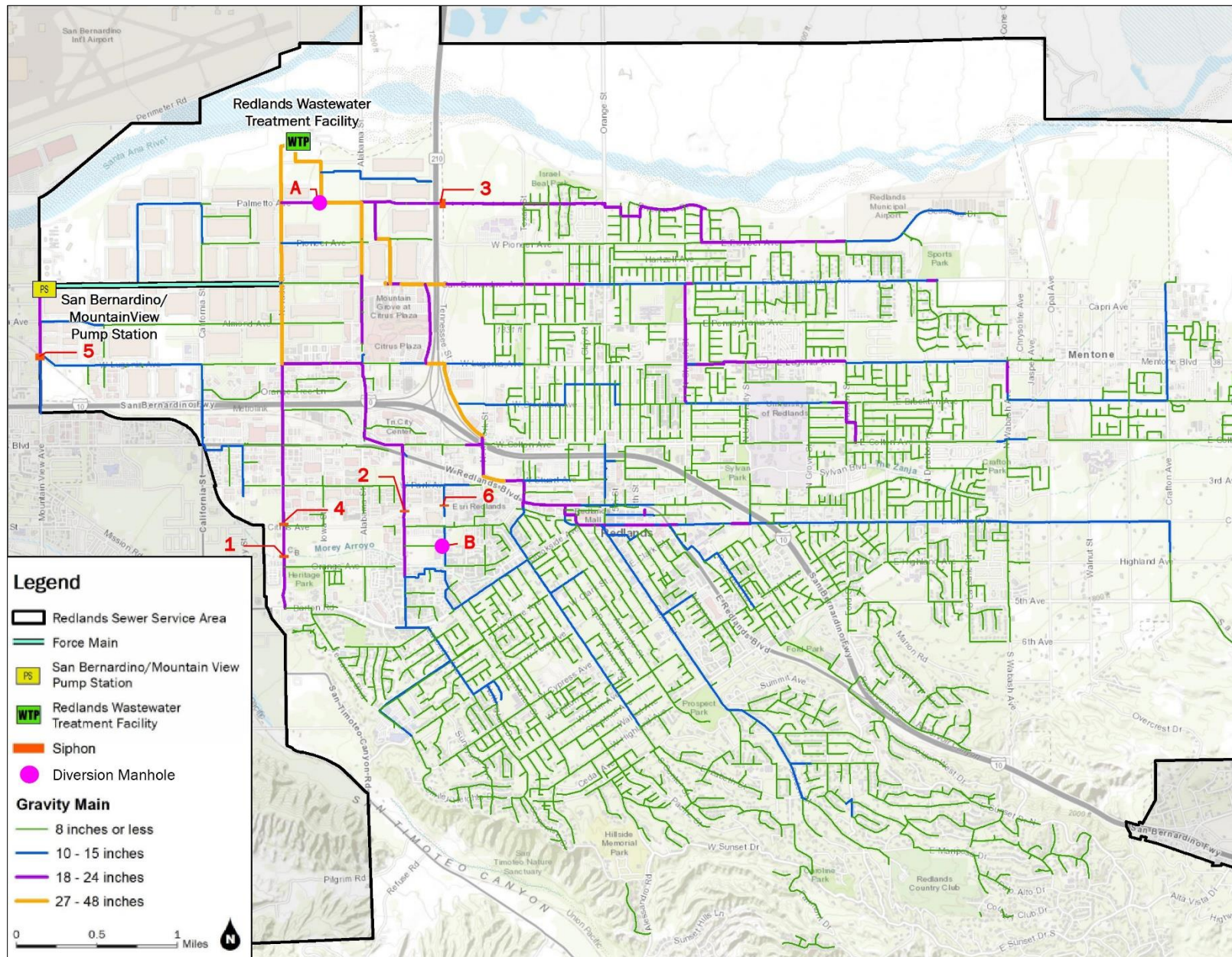

2.2 Siphons

The existing sewer collection system contains six (6) siphons, as detailed in **Table 2.3** and shown graphically in **Figures 2.2, 2.3** and **2.4**. An inverted siphon is a dip or sag in a sewer used to cross under a structure, channel, or stream. The sewer pipe in the inverted siphon is below the hydraulic grade line of the sewage flow and thus is always full of wastewater and under low pressure. In siphon design, it is good practice to have a multi-barrel siphon configuration to allow for both redundancy and cleaning during normal operation, as five of the six do in the City’s system. The reduced diameter of the siphons, as designed for the City’s multi-barrel configurations, increases flushing velocity, which is also a good design factor to note.

Table 2.3: Existing Sewer Siphons

Siphon No.	Name	Location & Manhole ID	Structure Crossing	Pipe Size (inch)	Length (ft)	U/S & D/S Pipe Diam (inch)	Install Year
1	Nevada & Orange	Nevada St north of Orange Ave (MH ID I37-5 to J37-4)	Morey Arroyo Creek	Triple Barrel / 15", 8", 15"	105	21" & 21"	1986
2	Kansas St	Kansas St at Orange Blossom Trail (MH ID J36-9 to J36-8) 3188	Flood Control Channel	Double Barrel / 10" & 15"	72	24" & 24"	1960
3	Domestic	West of the west end of Domestic Ave (MH ID N35-12 to N35-14)	Flood Control Channel	Triple Barrel / 12", 6", 12"	192	18" & 18"	1983
4	Nevada & Orange Blossom Trail	Nevada St at Orange Blossom Trail (MH ID I37-1 to J37-7)	Flood Control Channel	Triple Barrel / 15", 8", 15"	101	21" & 21"	1986
5	Mountain View Ave	Mountain View Ave at Lugonia Ave (MH ID L39-12 to L39-15)	Flood Control Channel	Triple Barrel / 12", 6", 12"	215	15" & 18"	1979
6	Tennessee St	Tennessee St at Orange Blossom Trail (MH ID J35-52 to J35-54)	Flood Control Channel	10"	64 ¹	10" & 10"	UNK

Notes:

¹ There was no as-built drawing provided for this siphon; therefore, siphon length was estimated using the straight-line distance from a GIS aerial dataset.

Figure 2.2: Orange Blossom Trail and Morey Arroyo Creek Siphons

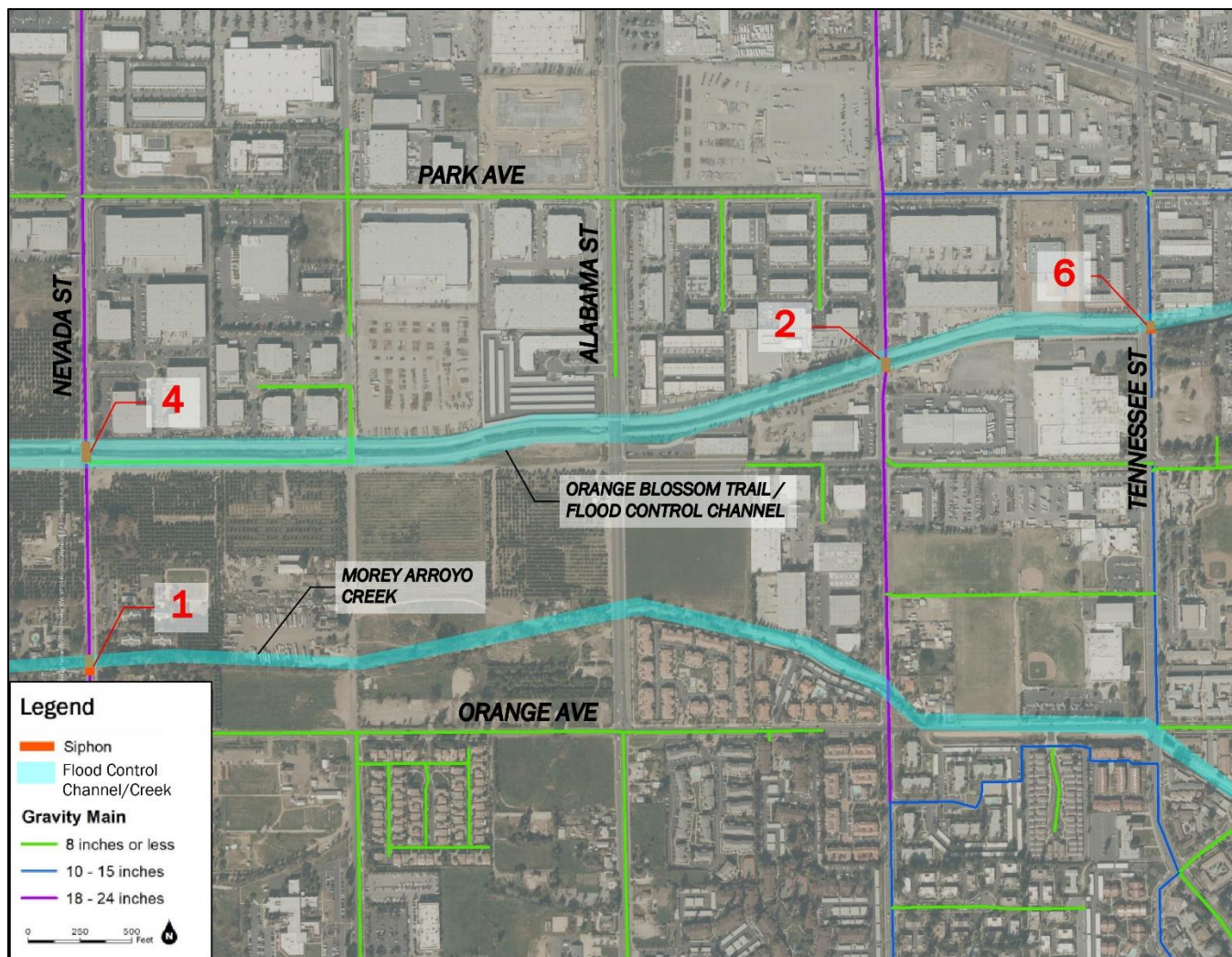

Figure 2.3: Domestic Ave West End Siphon

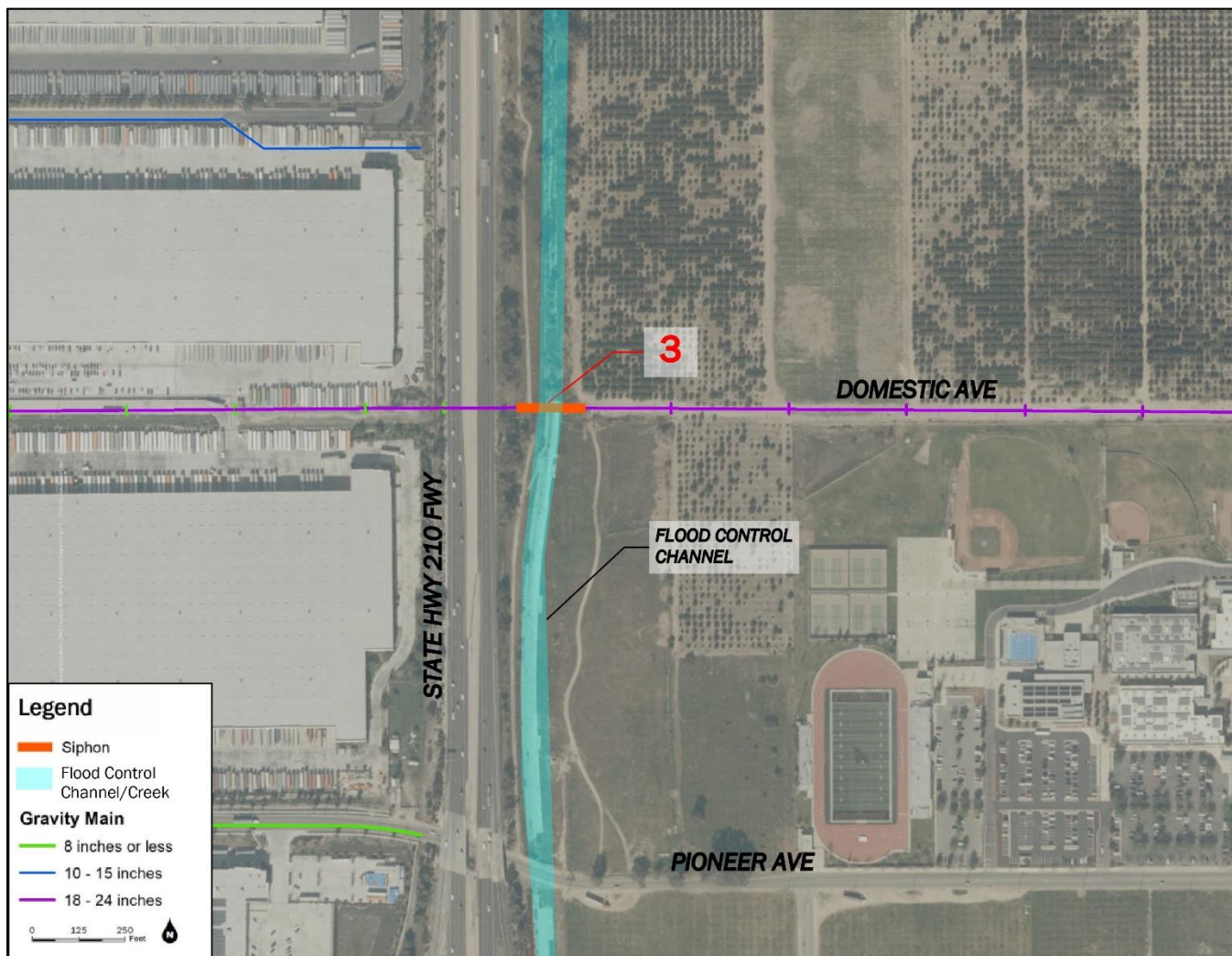
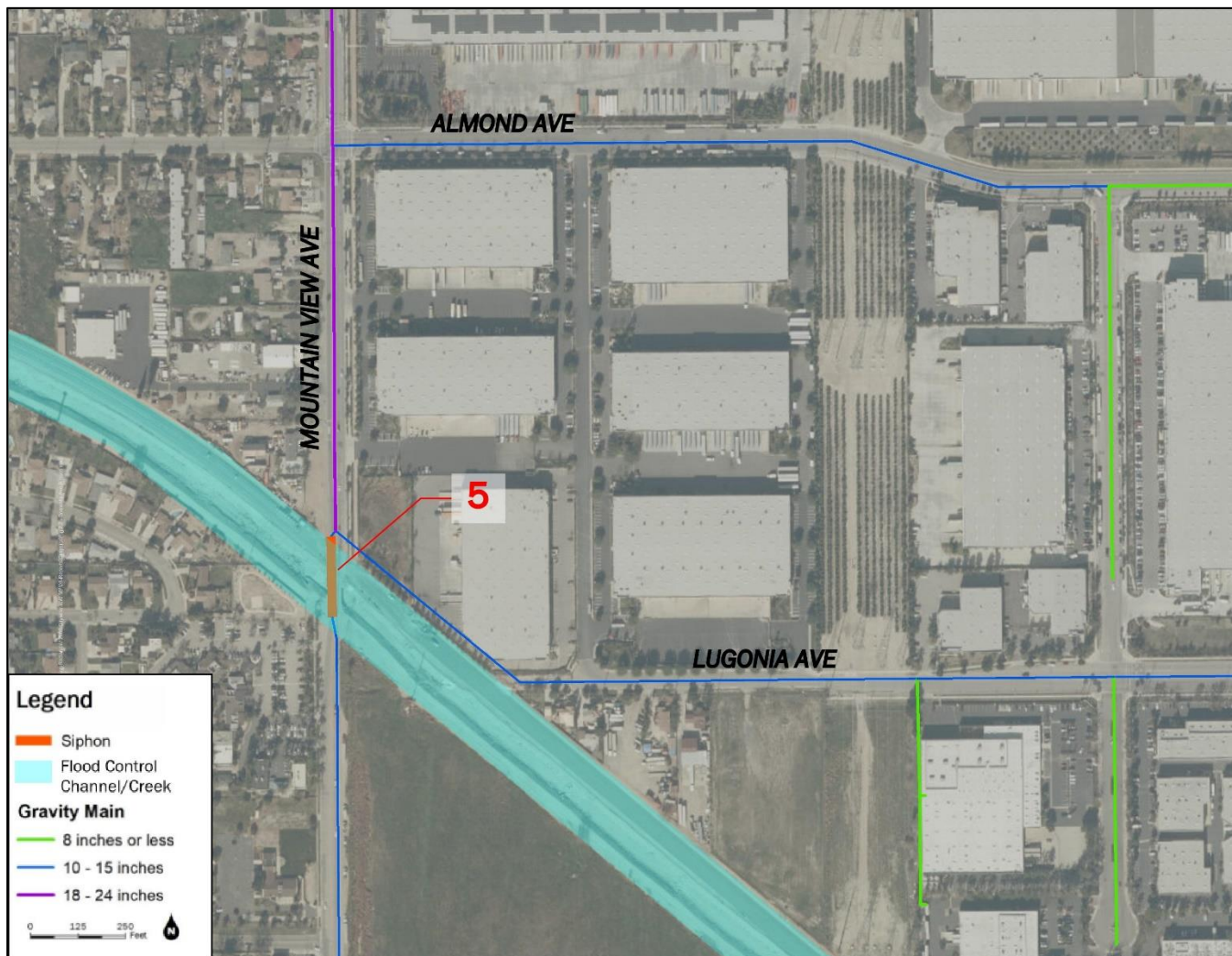

Figure 2.4: Mountain View Ave at Lugonia Ave Siphon



2.3 Diversion Manholes

Diversion manholes are unique manholes where sewer flow can be conveyed through more than one outlet. Typically, stop logs are used to intentionally block one outlet to force water into an intended downstream path. When evaluating system capacity, the accurate representation of flow patterns through diversion manholes is important. During the process of investigating the City’s GIS data, two (2) diversion manholes for pipes larger than or equal to 10-inches were identified, as shown graphically on Figure 2.1. The diversion manholes are listed in **Table 2.4**.

Table 2.4: Existing Diversion Manholes (10-inch pipe and larger)

ID	MH No.	Location	Main Invert Elevation (ft)	Main Invert Diameter (inch) and Cardinal Direction	Overflow Invert Elevation (ft)	Overflow Invert Diameter (inch) and Cardinal Direction	Difference Between Overflow and Main Inverts (ft)
A	MH_N37_8	Palmetto Ave 1,300 ft east of Nevada St	1195.2	48”, North	1197.89	20”, West	2.7
B	MH_I35_22	Tennessee St 650 ft north of Orange Ave	1262.31	10”, North	1262.81	8”, East	0.5

2.4 Sewer Lift Stations and Force Mains

The existing sewer system includes one (1) active, City-owned, operated and maintained sewer lift station located at San Bernardino Ave and Mountain View Ave, and shown graphically in **Figure 2.5**. In the event of a power outage, the San Bernardino/Mountain View Lift Station has a discharge pipe that diverts flow to the San Bernardino Wastewater Facility. A street view of the exterior of the lift station is shown in **Figure 2.6**. **Table 2.5** provides general available lift station information.

Table 2.5: City-Owned Sewer Lift Station Data

Lift Station Name	Location	Year Built	Number of Pumps	Design Flow per Pump (MGD)	Force Main Diameter (inch)	Individual Force Main Length (ft)
San Bernardino/ Mountain View	Southeast corner of San Bernardino Ave and Mountain View Ave	1989	2 (duty/standby) on VFD	4.0	Dual (12”/14”)	7,800

Figure 2.5: Sewer Lift Station Location Map

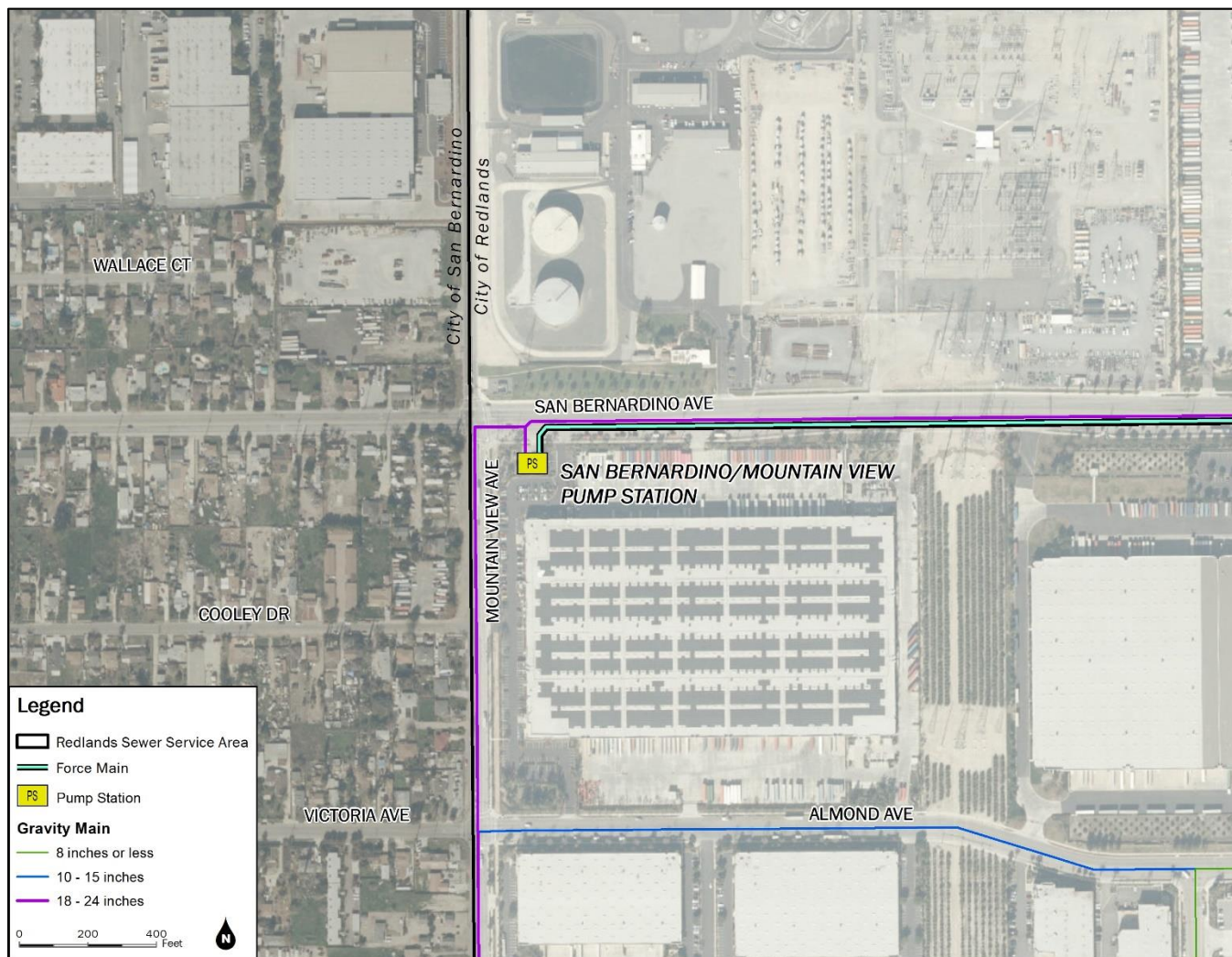
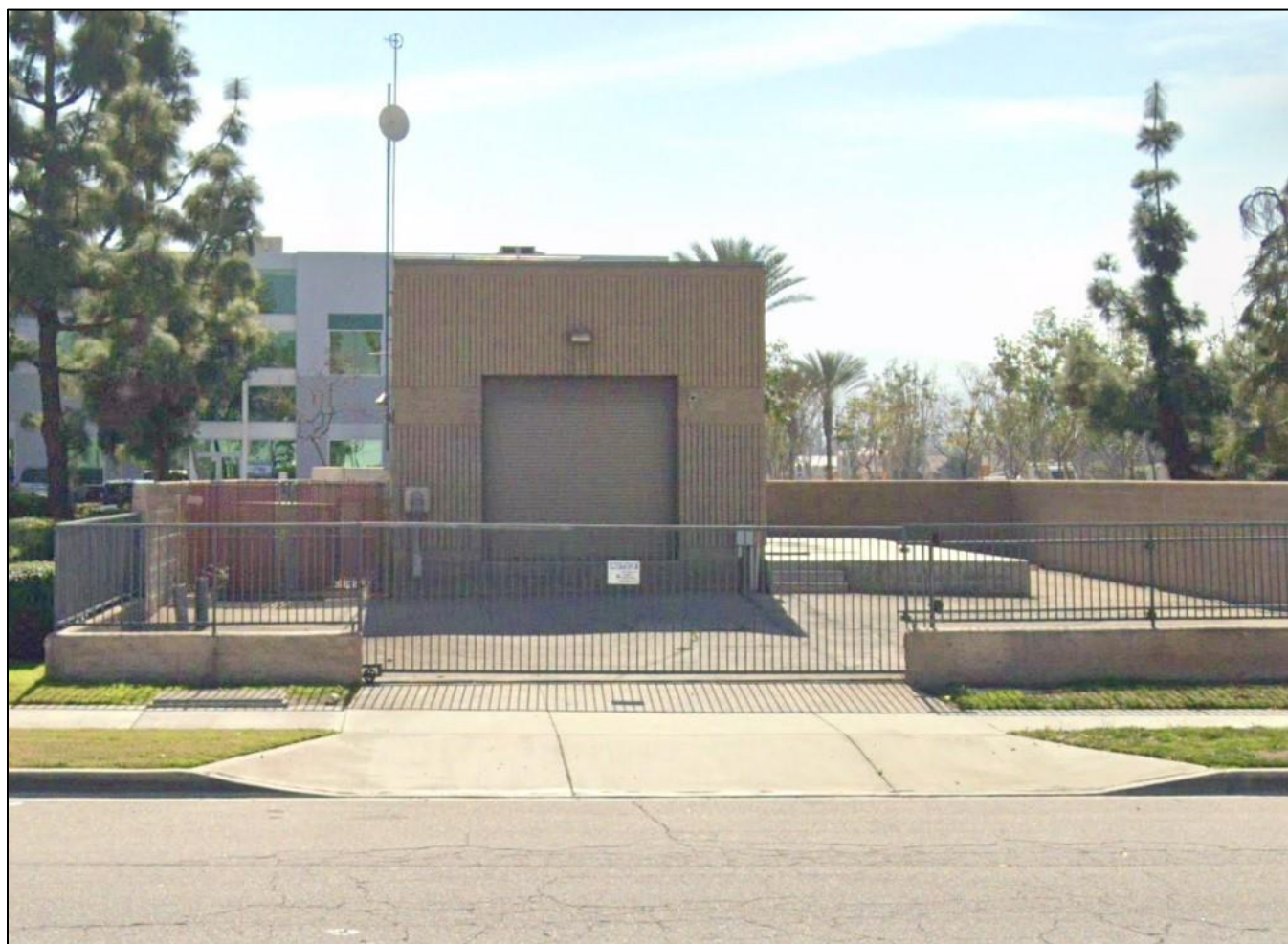

Figure 2.6: Street View of Mountain View Lift Station



2.5 Sewer Flow Patterns

The City does not have recent sewer collection system flow monitoring data. However, data from the WWTP influent flow meter was available to assess overall sewer flow patterns in the City’s collection system. Hourly influent flow meter data was obtained from the WWTP from March through September 2020 to evaluate wet weather and dry weather flow patterns, respectively. **Figure 2.7** presents a typical 24-hour dry weather flow pattern at the City’s WWTP. Systemwide average dry weather flow (ADWF) as measured at the WWTP is estimated at 5.8 MGD based on average flows for the month of August 2020. Figure 2.6 also shows one-minute WWTP influent flow meter data from the maximum wet weather influence day measured, which was the March 12, 2020 wet weather event. As evidenced in the graph, the WWTP influent flow meter measures to a maximum of 10 MGD. It is assumed that flow was greater than 10 MGD from approximately 3:30 pm to 6:30 pm that day. The WWTP influent flow meter was not able to measure flows above 10 MGD.

Figure 2.7: WWTP Influent Flow 24-Hour Dry Weather (August 7-8, 2020) and Wet Weather (March 12, 2020) Diurnal Curves

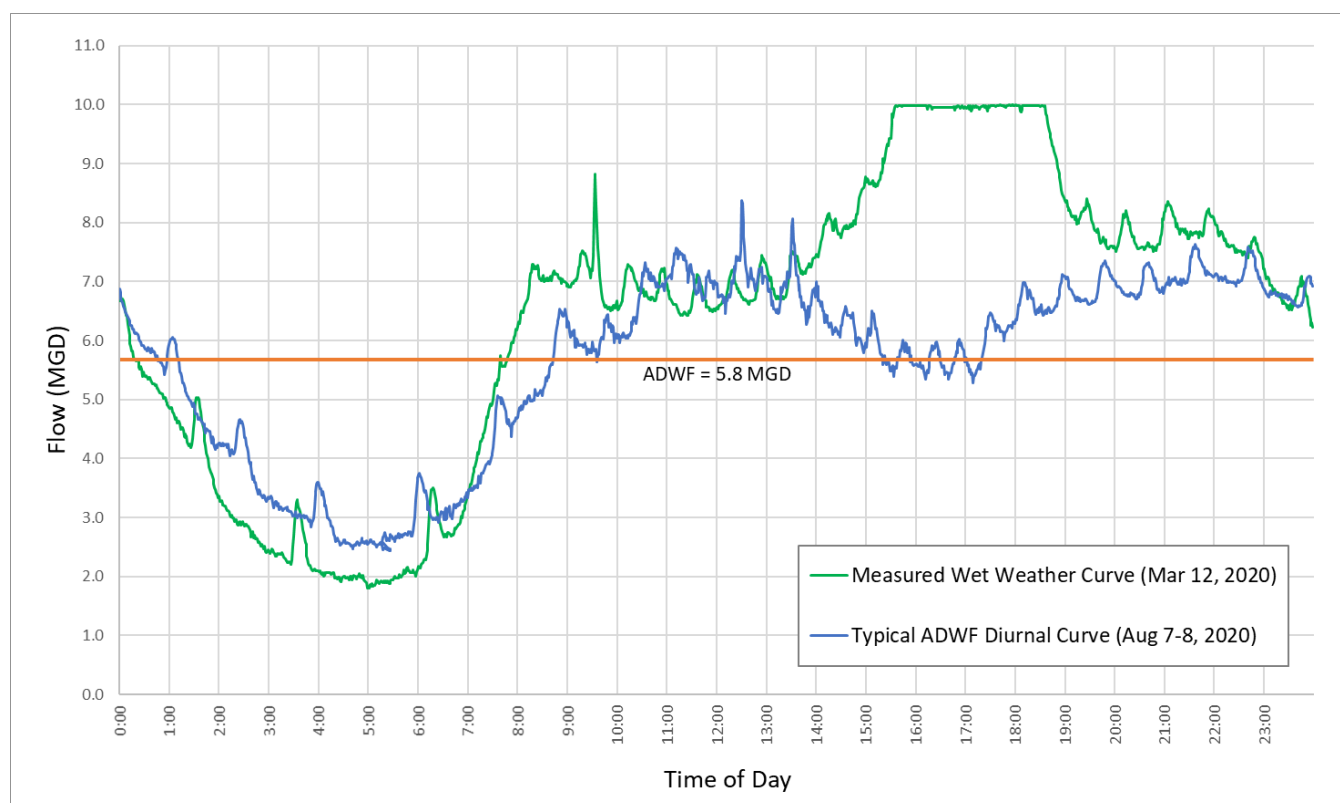

2.6 Sewer Treatment

The City of Redlands WWTP system provides for the collection, treatment, and disposal of municipal sewage. The system was constructed in 1962 and the most recent facility rehabilitation occurred in 2021. The WWTP has a permitted annual average flow of 9.5 million gallons per day (MGD). Currently, the WWTP operates two parallel treatment systems, a membrane bioreactor (MBR) process with the capability to produce up to 6.0 MGD of recycled water and a conventional activated sludge (CAS) process with a capacity of 3.5 MGD. Typical influent

average daily flow is approximately 5.8 MGD. More detail on the City's sewer treatment program can be found in Section 5.

2.7 Land Use

Table 2.6 summarizes the distribution of various land uses within the City's sewer collection system service area, which extends beyond the City boundary and into San Bernardino County. **Figure 2.8** presents the land use map of the sewer service area based on the most recent City data provided.

Table 2.6: Land Use Summary

Land Use Type	Area (acres)	Percentage of Total City Area
Single Family Residential ¹	8,095	26%
Multi-Family Residential	590	2%
Commercial	1,063	3%
Industrial	1,831	6%
Public/Institutional ²	5,394	18%
Open Space/Recreation ³	11,155	36%
Agricultural	2,553	8%
TOTAL	30,681	100%

Notes:

¹ Includes mobile home parks.

² Includes public facilities, transportation, schools, utilities, and right-of-way

³ Includes parking lots, but does not include bodies of water

Figure 2.8: Land Use within Sewer Service Area

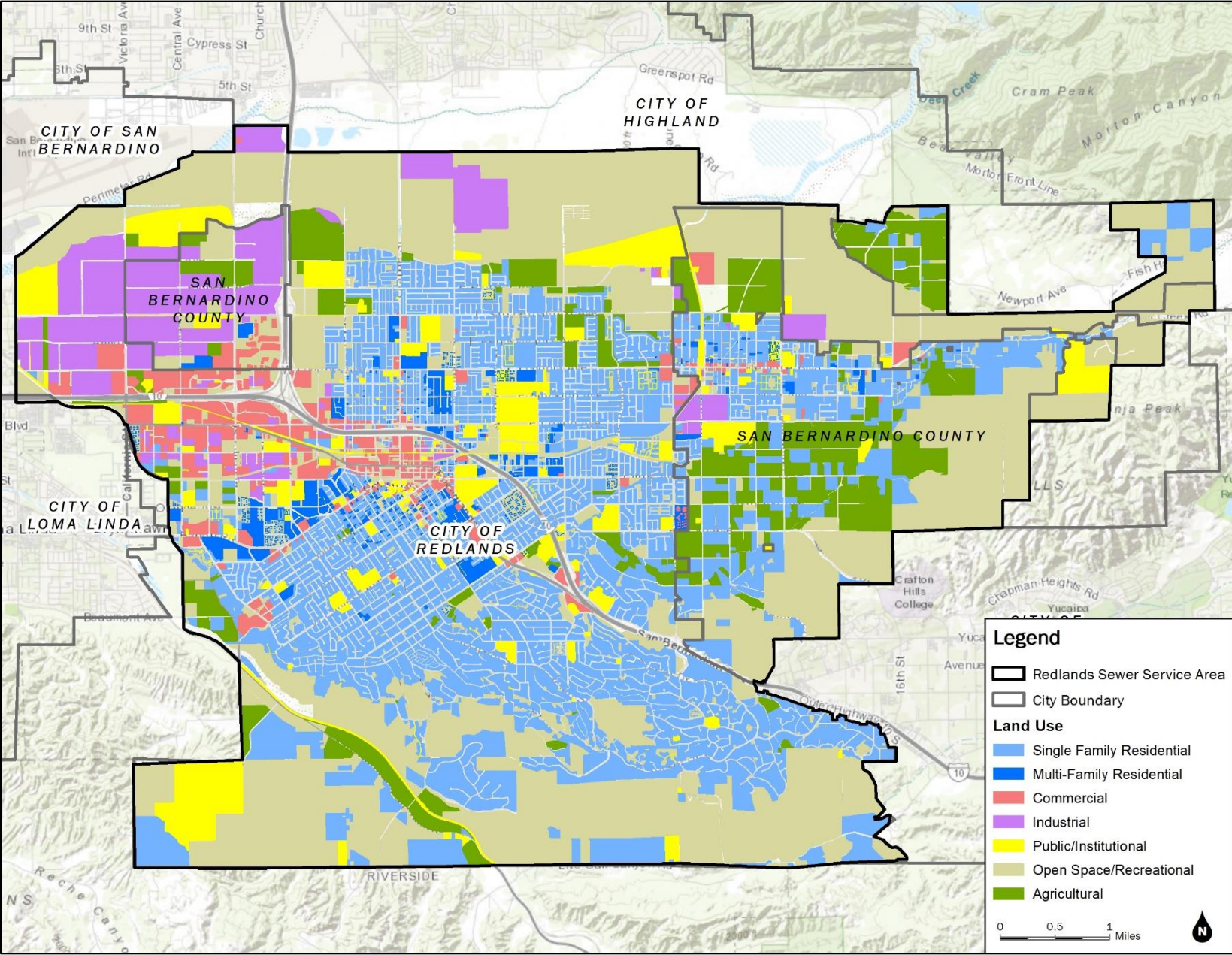



INTENTIONALLY LEFT BLANK

3 Future Flow Projections

3.1 Population Growth Projections

This section describes the City's current and projected population throughout the 2070 planning horizon.

3.1.1 Existing Population

According to the 2019 Community Profile available on the City's website, the current population of the City was estimated at 72,172 in 2019.

3.1.2 Projected Population

Table 3.1 provides future (2025 through 2070) population projections based on population growth estimates provided in the City of Redlands General Plan 2035 (written in 2017), which projected population growth through 2035.

Table 3.1: Existing and Projected Population

Year	2019 ¹	2025 ²	2030 ²	2035 ²	2040 ³	2045 ³	2070 ⁴
Population	72,172	73,500	76,300	79,100	82,200	85,500	90,000

Notes:

¹ Current estimate from City website for 2019.

² Assumed based on 0.8% growth from the City's 2035 General Plan.

³ Assumes 0.8% growth rate from the City's 2035 General Plan continues to 2045.

⁴ Per 2035 General Plan, buildout population is estimated to be approximately 90,000.

3.2 Projected 2030 (Near-Term) Flow Projections

According to data received from City staff, there are 55 development projects currently planned to be built between 2020 and 2030. Of the 55 projects, 22 are residential (totaling approximately 1,869 dwelling units), 20 commercial, seven (7) industrial, two (2) institutional, and three (3) hotels. Additionally, there is one large mixed-use development, the Transit Villages Specific Plan project, consisting of 2,000 high density residential dwelling units, 10.4 acres of commercial use, 1.3 acres of institutional use, and two hotels. Eleven (11) of the projects are redevelopment projects. The location of the development projects included in near-term are shown in **Figures 3.1** and **3.2**. **Appendix A** provides additional detail on each of the 55 near-term development projects shown in the following figures.

To estimate sewer generation from planned development projects, sewage flow factors were developed for each land use type, based on information from neighboring agencies and industry standards. **Table 3.2** presents the unit sewage flow factors applied to 54 of the 55 near-term developments (the Transit Villages Specific Plan development has its own unit sewage flow factors listed in a subsequent table). The projected sewage load of each near-term development project was used in conjunction with 2020 measured flows to create the hydraulic model near-term (2030) loading scenario, as described in more detail in Chapter 4.

Figure 3.1: Near-Term Development Projects Location Map

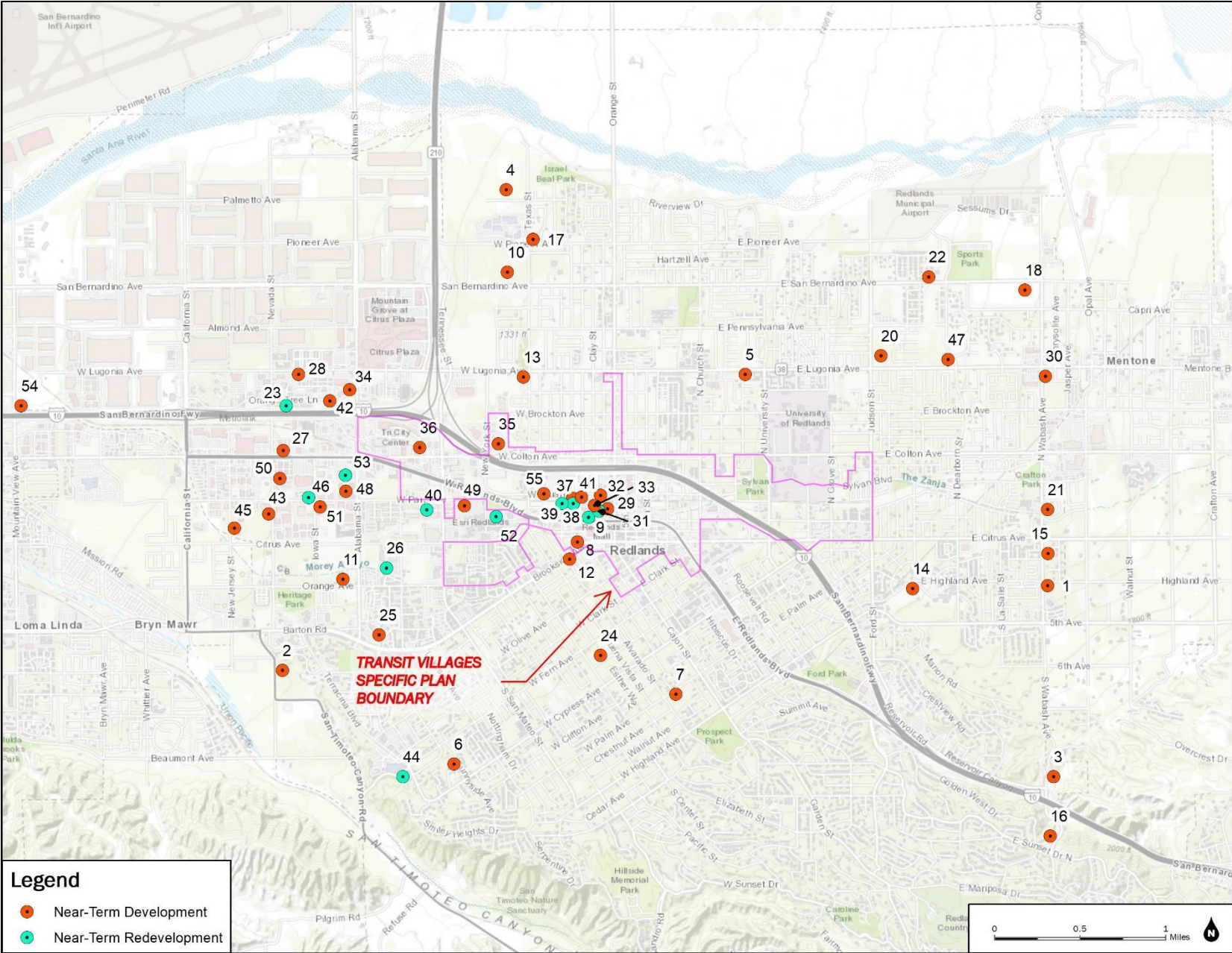

Figure 3.2: Near-Term Development Projects Location Map (Downtown Redlands Area)

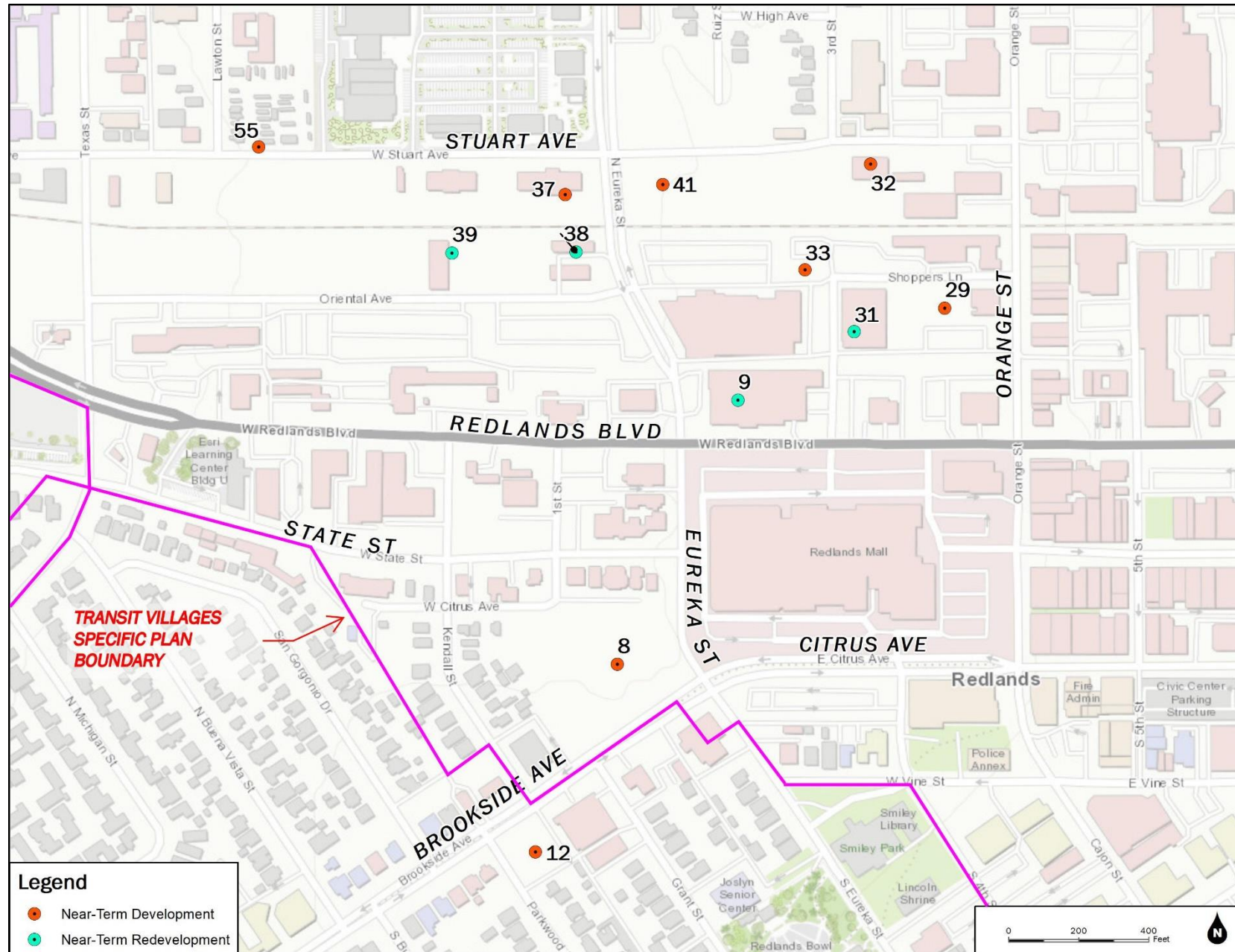

Table 3.2: Unit Sewage Flow Factors

Land Use	Unit Flow Factor		
	gpd/DU	DU/acre	gpd/acre
High Density Residential	120	30	-
Medium Density Residential	165	15	-
Single Family Residential	210	3	-
Hotel	110		-
Institutional	-		1,000
Commercial	-		3,000
Industrial	-		3,200

Notes:
gpd = gallons per day
DU = dwelling unit

The total projected near-term sewage loads from the 55 planned developments are summarized in **Table 3.3**.

Table 3.3: Additional Loads from Near-Term Developments

Development Type	Dev't Count	Dev't Acreage	Total No. DUs	Total Hotel Rooms	ADWF (MGD)
High Density Residential	2	1.5	177	-	0.02
Medium Density Residential	5	37.32	683	-	0.11
Single Family Residential	15	342.1	1,009	-	0.21
Hotel	3	6.04	-	288	0.03
Institutional	2	21.4	-	-	0.02
Commercial	20	36.3	-	-	0.11
Industrial	7	41.5	-	-	0.13
Transit Villages Specific Plan ¹	1	75.6	2,000	219	0.47
Totals	55	561.76	3,869	507	1.1

Notes:

¹ Transit Villages Specific Plan development is further described in Tables 3.4 & 3.5.

Note that the Transit Villages Specific Plan projected load of 0.47 MGD is 43% of the total projected loads of all near-term developments combined (1.1 MGD). The ADWF of Transit Villages used sewage flow factors from draft Transit Villages Specific Plan, as shown in **Table 3.4**. **Table 3.5** breaks down the different land use types and associated ADWF of the Transit Villages Specific Plan Development.

Table 3.4: Transit Villages Unit Sewage Flow Factors¹

Land Use	Unit Flow Factor	
	gpd/DU	gpd/acre
High Density Residential (HDR)	210	-
Hotel	100 ²	-
Institutional	-	4,536
Commercial	-	2,178

Notes:

gpd = gallons per day

DU = dwelling unit

¹ Source: Table 8-3 Draft Transit Villages Specific Plan

² Hotel unit factor is 100 gpd per room

Table 3.5: Transit Villages Specific Plan Development

Development Type	Acreage	Size (DU)	Size (Rooms)	ADWF (MGD)
High Density Residential (HDR)	63.9 ¹	2,000	-	0.42
Hotel		-	219	0.02
Institutional	1.3	-	-	0.01
Commercial	10.4	-	-	0.02
Totals	75.6	2,000	219	0.47

Notes:

¹ Transit Villages Specific Plan does not differentiate between the HDR and Hotel areas.

Using the estimated 2020 ADWF of 5.8 MGD from WWTP influent flow meter data, the addition of the estimated loads from the 55 developments anticipated to be built by 2030 projects a system-wide ADWF of approximately 6.9 MGD in 2030. While approximately 11 of the 55 projects are redevelopment (replacement of existing sewer loads), the full 1.1 MGD of anticipated ADWF was used to augment existing flows to provide a conservative sewer flow growth estimate.

3.3 Projected 2045 (Long-Term) Flow Projections

The City's existing and projected populations in Table 3.1 were used to calculate the percentage increase in population from 2019 to 2045 (i.e. the population growth factor). This population growth factor of 1.18 (calculated as the 2045 population of 85,500 divided by the 2019 population of 71,172) was multiplied across the existing (2020) collection system ADWF to estimate the increase in sewer loading due to a general infill scenario throughout the service area. The resulting increase in ADWF through 2045 due to infill was summed with the total near-term (2030) development ADWF in Table 3.3 to determine the total projected 2045 ADWF sewer loading.

3.4 Projected 2070 (Ultimate) Flow Projections

As with the 2045 (Long-Term) projections, the projected ultimate sewer flows were determined using a population growth factor, based on the percentage increase in population from 2019 to 2070 in Table 3.1. The population growth factor of 1.25 (calculated as the 2070 population of 90,000 divided by the 2019 population of 71,172) was multiplied across the existing (2020) collection system ADWF to estimate the increase in sewer loading due to a general infill scenario throughout the entire service area. The resulting projected increase in ADWF through 2070 due to infill was summed with the near-term (2030) development ADWF to produce the total projected 2070 (ultimate) ADWF sewer loading.

3.5 System Flow Summary

Wet weather flows were estimated for each scenario using the 2020 wet weather flow scenario as the base wet weather flow rate, as captured by the March 12, 2020 wet weather event, and adding the increase in ADWF for each planning period described in the previous sections. For example, the estimated 2030 wet weather flow scenario is equal to the measured 2020 AWWF of 6.5 MGD plus the increase in ADWF between 2030 and 2020 of 1.1 MGD; for a total estimated 2030 AWWF of 7.6 MGD. **Table 3.6** summarizes the ADWF and AWWF in each sewer model loading scenario, from existing (2020) to projected ultimate (2070).

Table 3.6: Existing and Projected Sewer Flows

Year	ADWF (MGD)	AWWF (MGD)
2020	5.8	6.5
2030	6.9	7.6
2045	7.7	8.4
2070	8.0	8.7

4 Collection System Capacity Analysis

The capacity of the sewer system is analyzed with a hydraulic model and results are evaluated with respect to established and verified design criteria to identify capacity deficiencies. This section describes the design and evaluation criteria, the collection system hydraulic model development and the results of the existing and future capacity evaluations of the City’s sewer collection system. The evaluation method employs the use of the Innovyze® InfoSewer hydraulic modeling software, which performs hydraulic calculations within extended period simulations (EPS).

4.1 Design Criteria

Design and evaluation criteria provide the standards against which the existing system is evaluated. These criteria are also the basis for planning of new facilities to improve existing service or to handle future wastewater flows. The design criteria recommended for use in this Master Plan Update are based on the 1998 City of Redlands Wastewater Collection System Master Plan’s sewer analysis criteria, criteria from similar and neighboring sewer agencies, as well as industry standards. The recommended sewer design and evaluation criteria for this study are summarized in **Table 4.1**. It is noted that diurnal patterns used in the hydraulic analysis are based on historical dry and wet weather peak flows observed from WWTP influent flow data, as previously presented in Section 2 and discussed in more detail at the end of this section.

Table 4.1: Design and Evaluation Criteria

Gravity Main Criteria	Minimum pipe diameter	8-inches
	Minimum allowable velocity at peak dry design flow	2 ft per sec
	Manning’s Roughness Coefficient	0.013
Depth-to-Diameter Ratio for Gravity Mains	For sewer mains ≤ 12-inch	0.50
	For sewer mains > 12-inch	0.75
Lift Station Criteria	Minimum Number of Pumps	2
	Minimum Pump Capacity	Duty pumps capable of handling PWWF
	Standby Capacity	100% of the largest pump capacity
	Emergency Storage Capacity ¹	6 hours of ADWF
Velocity for Force Mains	Minimum allowable velocity	2.5 ft per sec
	Maximum allowable velocity	8 ft per sec

Note:

¹ Emergency storage capacity calculated based on volume between lag pump start level and max high-water level in the wet well.

The most common capacity evaluation criterion for gravity sewers is the ratio of depth of flow divided by diameter (d/D), which is calculated in the hydraulic model based on Manning’s Equation. The capacity of each gravity sewer is based on the relative depth of flow within the respective pipeline reach. Gravity sewers are not typically

designed to flow full, as unoccupied space at the top of the pipe is used for conveyance of sewage gases and to provide contingent capacity for wet weather inflow and infiltration (I&I). Pipeline sizing is typically based on the pipeline flowing 75% full at the PWWF if the pipe is larger than 12-inches in diameter ($d/D = 0.75$). For a pipeline with a diameter of 12-inches or smaller, a d/D factor of 0.50 is used.

Manning's coefficient of friction factors for pipelines vary with the material and the age of the pipe. A roughness factor as indicated by a Manning's coefficient ("n") of 0.013 is commonly used to evaluate existing gravity sewers and for projection of future sizing needs. Studies have indicated that this value provides a conservative estimate of the average friction factor of pipelines over their useful life.

In the design of sewer lift stations, it is required that spare pumping units be included for mechanical reliability. A wastewater facility must be capable of conveying peak wet weather flows with the largest operating unit out of service. Lift stations are typically equipped with two or more pumps, including one pump of the largest size as a standby unit, and have a secondary or emergency power source consisting of either installed generators or a connection for a portable generator. In lieu of emergency backup power, a lift station may have the ability to overflow to another facility with sufficient capacity to accommodate excess flows. Force mains are evaluated based on maintenance of a minimum or maximum allowable flow velocity, recommended to vary between 2.5 and 8.0 fps. Velocities less than 2.5 fps may result in deposition in the force main, while velocities greater than 8.0 fps can damage the pipeline through excessive abrasion.

4.2 Pipeline Evaluation

As stated in the previous section, the design criteria for gravity sewers provides unoccupied space at the top of the pipe for conveyance of sewage gasses and to provide contingent capacity for wet weather inflow and infiltration. In this Master Plan, the PWWF analysis assumes the timing of peak I&I rates coincide with the PDWF, and the duration of the PWWF condition is brief. When gravity pipelines are evaluated to determine if there is adequate capacity under the PWWF condition, separate pipeline evaluation criteria are often used to determine the permissible flow level before the pipeline should be upsized. These criteria are often referred to as "trigger" criteria. Based on criteria from the City's 1998 master plan, consistent with those established by other agencies, gravity sewers are permitted to flow up to 100% full ($d/D = 1.0$) at the PWWF before improvement projects will be identified.

4.3 Hydraulic Model Development

The principal tool utilized in the capacity analysis is a hydraulic model that simulates flow conditions, such as wastewater depth, flow rate, and velocity within the City's wastewater collection system. The City had GIS data prepared as part of the 1998 Wastewater Collection System Master Plan. As part of this master planning effort, the available GIS data was converted to InfoSewer® modeling software, which is an ArcGIS-based computer program developed by Innowatze® that allows for direct importation of the existing sewer GIS data maintained by the City. Existing sewer GIS data imported into the model includes pipelines and manholes.

Due to the absence of a significant number of invert elevations in the existing GIS data for pipelines under 10-inches in diameter, the hydraulic model was developed for larger diameter (10-inches and greater) pipelines only, plus a few key sections of 8-inch diameter pipe. These pipelines constitute the reaches with the highest amounts of wastewater flow and therefore the higher potential impact in the event of a sewer overflow. Controls in the model were added at the sewer lift station, as well as the two diversion structures in the model, to ensure modeled flows matched field conditions. Additionally, sewer as-builts were used to verify or update the model for areas where the existing data created hydraulic conditions not typical of a gravity fed sewer system.

4.3.1 Dry Weather Flow Loading

Recent collection system flow monitoring data was not available for loading and calibration of the hydraulic model. In order to allocate flows appropriately, average dry weather wastewater flows measured at the WWTP in August 2020 were distributed proportionately through the existing system based on water usage data from the City’s water billing database for calendar years 2017, 2018 and 2019. Therefore, areas with higher water usage were assumed to have higher relative wastewater generation. Once distributed, modeled flows at the WWTP discharge location in the model were calibrated to measured WWTP influent flows to ensure total dry weather sewer flows in the system were consistent with real world data. This calibration is described in Section 4.3.3.

4.3.2 Wet Weather Flow Loading

As with the dry weather flow loading, wet weather flow monitoring data within the collection system were not collected in the field. Modeled flows at the WWTP location in the model were calibrated to measured WWTP influent flows to ensure total wet weather sewer flows in the system were consistent with real world data on March 12, 2020. This calibration is described in the following section.

4.3.3 Model Calibration

Model calibration is a process to ensure model outputs, including average flows, peak flows, and diurnal flow patterns, are consistent with field measured data. For this hydraulic analysis, because collection system flow monitoring data was not available upstream of the WWTP, model calibration was achieved by comparing and adjusting average dry and peak wet weather flows and 24-hour diurnal flow curves used in the model until the flow patterns within the model output replicated field flow monitoring results at the WWTP influent flow meter for both existing dry and wet weather scenarios. Existing dry weather conditions were based on WWTP influent flow meter data from August 2020, while existing wet weather conditions were based on WWTP influent flow meter data from the March 12, 2020 wet weather day. The hydraulic model was considered calibrated when both hourly flows and 24-hour flows were within 10% of field measurements.

Table 4.2: Sewer Hydraulic Model Calibration Results

2020	WWTP Field Measured Flow (MGD)	WWTP Modeled Flow (MGD)	Percentage Difference
ADWF	5.8 ¹	5.8	0%
PDWF	8.1 ²	8.1	0%
AWWF	6.4 ³	6.5	2%
PWWF	12.0 ⁴	12.1	1%

Notes:

¹ Based on average flows measured from August 1 through August 31, 2020.

² Value based on average of daily peak flows measured from August 1 through August 31, 2020.

³ Value based on average flows measured on March 12, 2020 wet weather day.

⁴ Actual measured PWWF on March 12, 2020 was 10 MGD due to limitations of the WWTP influent flow meter, though flow trajectories implied this value was higher. With concurrence with City staff, a value of 12 MGD was used to calibrate the hydraulic model for PWWF.

The following 24-hour flow graph shown on **Figure 4.1** presents the field measured and resultant model dry weather flows at the WWTP in the 2020 dry weather hydraulic model scenario.

Figure 4.1: 24-Hour WWTP Dry Weather Calibration

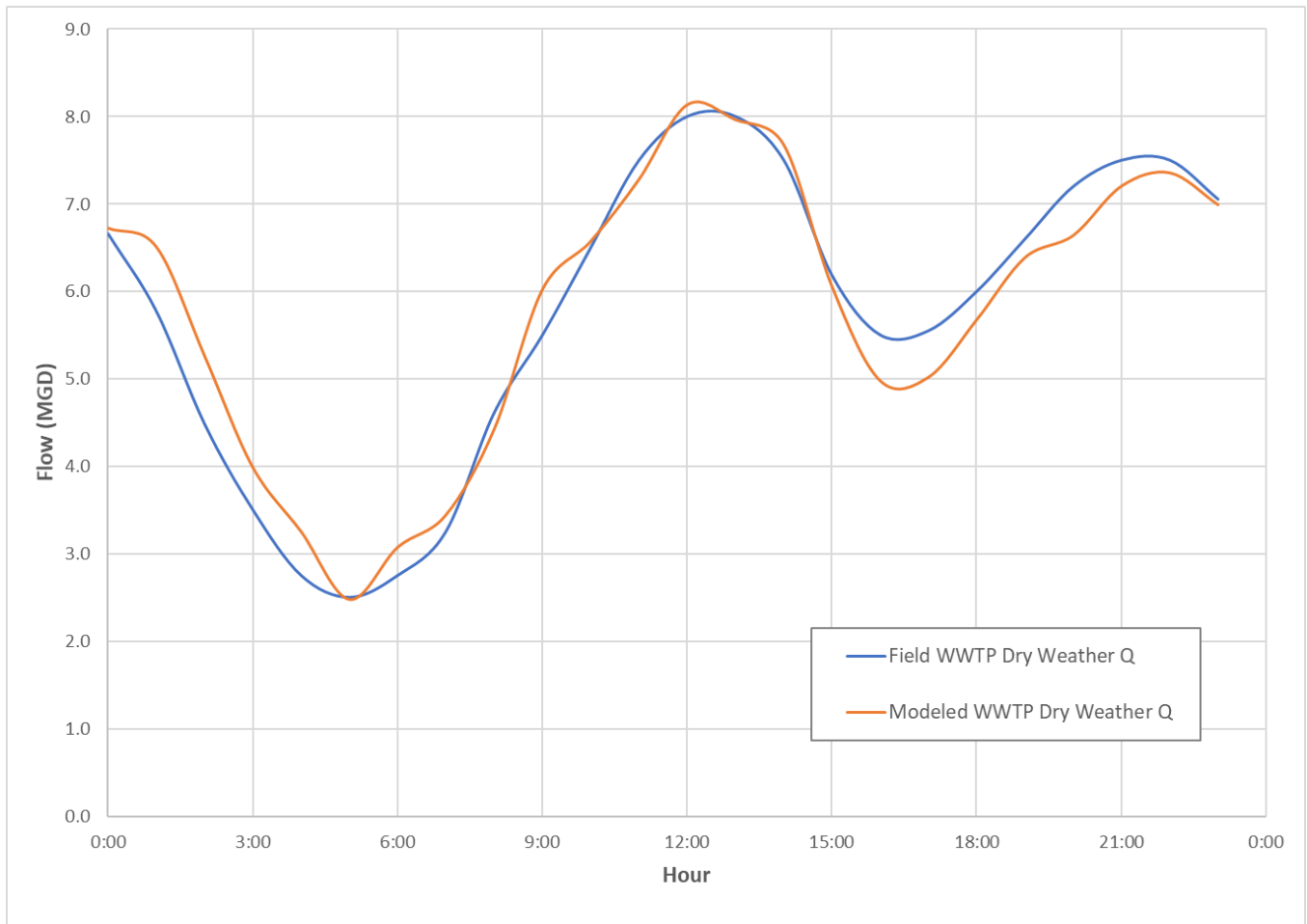

The following 24-hour flow graph (**Figure 4.2**) shown presents the field measured, estimated, and modeled wet weather flows at the WWTP in the 2020 wet weather hydraulic model scenario. Note that the WWTP inflow meter cannot measure flows above 10 MGD, though flow trajectories implied this value was higher; therefore, with concurrence with City staff the peak flow was estimated at to be 12 MGD and to occur between the hours of 3:00 PM and 6:00 PM.

Figure 4.2: 24-Hour WWTP Wet Weather Calibration

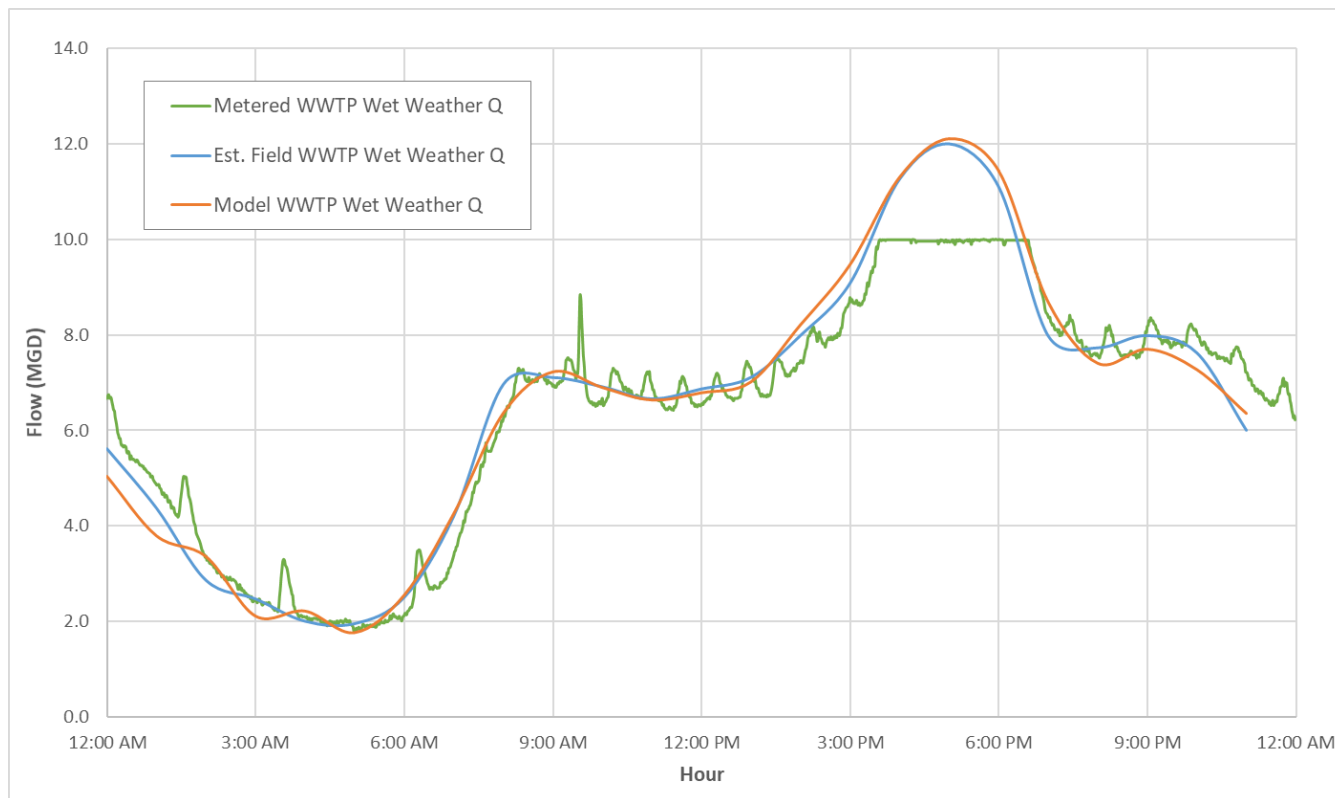

4.4 Capacity Analysis

The following sections summarize the results of the existing (2020), near-term (2030), long-term (2045) and buildout (2070) capacity analyses for the City’s wastewater collection system. Capacity analyses, and sizing of collection system pipelines, are based on an anticipated maximum peak wet weather flow (PWWF) condition; therefore, the PWWF loading values presented in Chapter 3 were used for these analyses. Results of lift station and forcemain analyses are presented in Section 4.4.5.

4.4.1 Existing (2020) Flow Capacity Evaluation

A capacity analysis of the existing collection system was performed under 24-hour peak wet weather flow (PWWF) loading conditions. An extended period simulation (EPS) was run on the system. Maximum depth over diameter (d/D) ratios for all pipes were compared against the d/D of 1.0 (full pipe) trigger criteria discussed in Section 4.2. Pipes that reach the trigger criteria were flagged for potential upsizing as a CIP project. Three (3) pipeline reaches were found to exhibit a d/D of 1.0 in the existing (2020) PWWF analysis, as presented in **Figure 4.3**. Each site is shown in more detail in **Figures 4.4, 4.5 and 4.6**. The recommended upsizing for the pipes listed in **Table 4.3** were analyzed under buildout (2070) PWWF conditions and found to meet the gravity main criteria listed in Table 4.1.

Initially, the recommended upsizing for the pipeline running between Palmetto Ave and San Bernardino Ave (east of Alabama St) was 36-inches. However, capacity analysis of long-term (2045) peak wet weather flow conditions revealed additional segments of pipe at this location reaching the d/D of 1.0 trigger criteria. To avoid mobilizing two capacity improvement projects at the same location, the recommendation includes the full length of deficient pipelines found in both scenarios. Additionally, due to the pipeline being located within an industrial site, it is recommended the pipeline be re-routed to be located withing roadways. The new proposed route for this stretch of pipe allowed for increased slope. A model simulation of the system with the new proposed alignment and the recommended upsizing confirmed flow velocities did not drop below 2 fps under existing conditions.

Table 4.3: Recommended Existing (2020) System Capacity Improvements

Project ID	Location	Ex. Diameter (inch)	PWWF Max d/D	Length (LF)	Recommended Upsizing (inch) ¹
P-1	Cajon St, between Cypress Ave and Fern Ave	10"	1.0	1,350	12"
P-2	Cajon St, south of E Citrus Ave	12"	1.0	100	15"
P-3	Alley east of Alabama St, between San Bernardino Ave and Palmetto Ave	24" and 30"	1.0	3,100	24" (920 LF) 36" (2700 LF) ²
TOTAL				4,550	-

Notes:

¹ Recommended upsizing based on accommodating projected buildout (2070) PWWF sewer loads.

² Due to this pipeline currently being located within the driveway of an industrial building, a new alignment is proposed for this section of pipe, as detailed in further detail in Chapter 6.

Figure 4.3: Results of Existing (2020) PWWF Capacity Evaluation

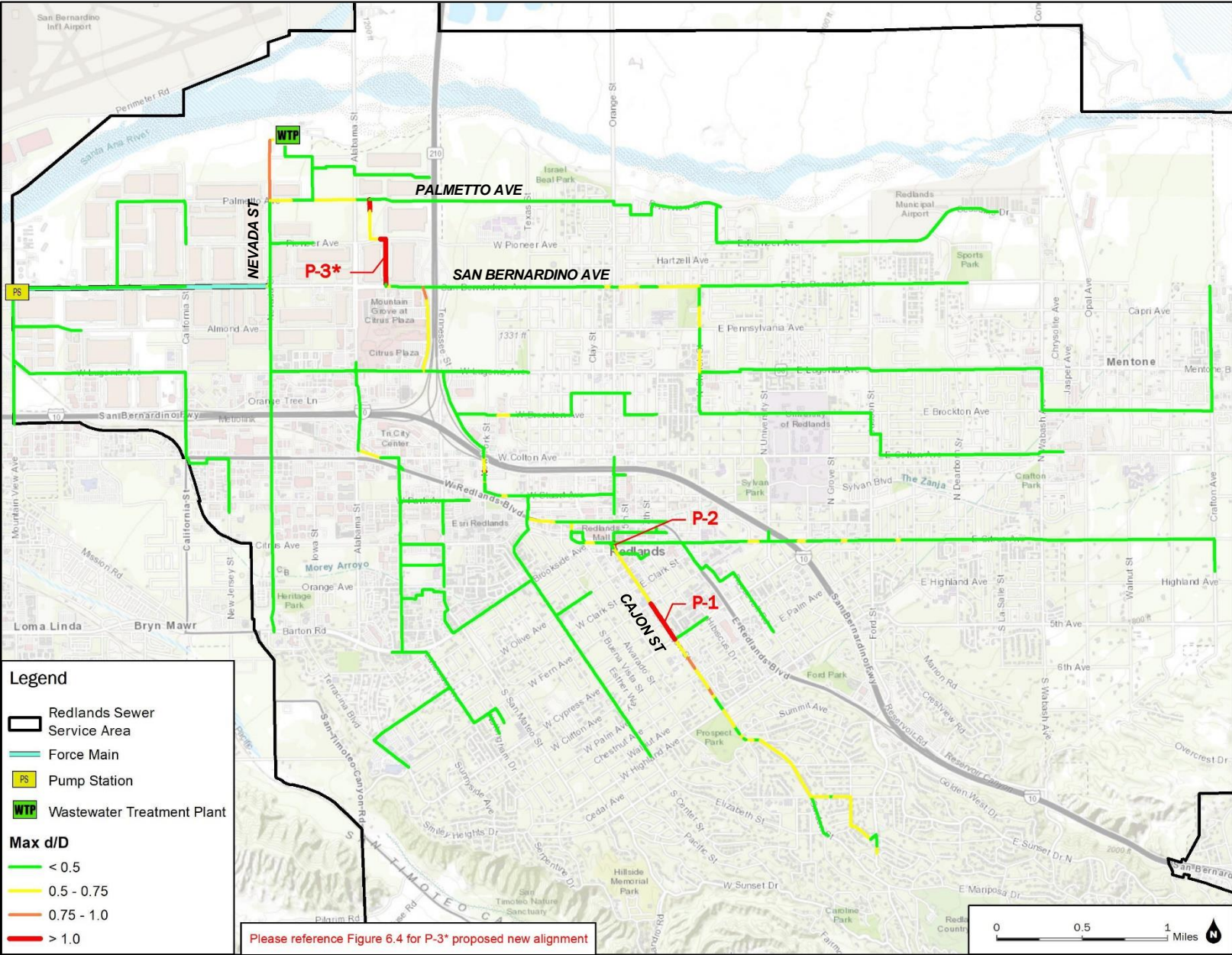

Figure 4.4: Cajon St (Between Cypress Ave and Fern Ave) Capacity Evaluation

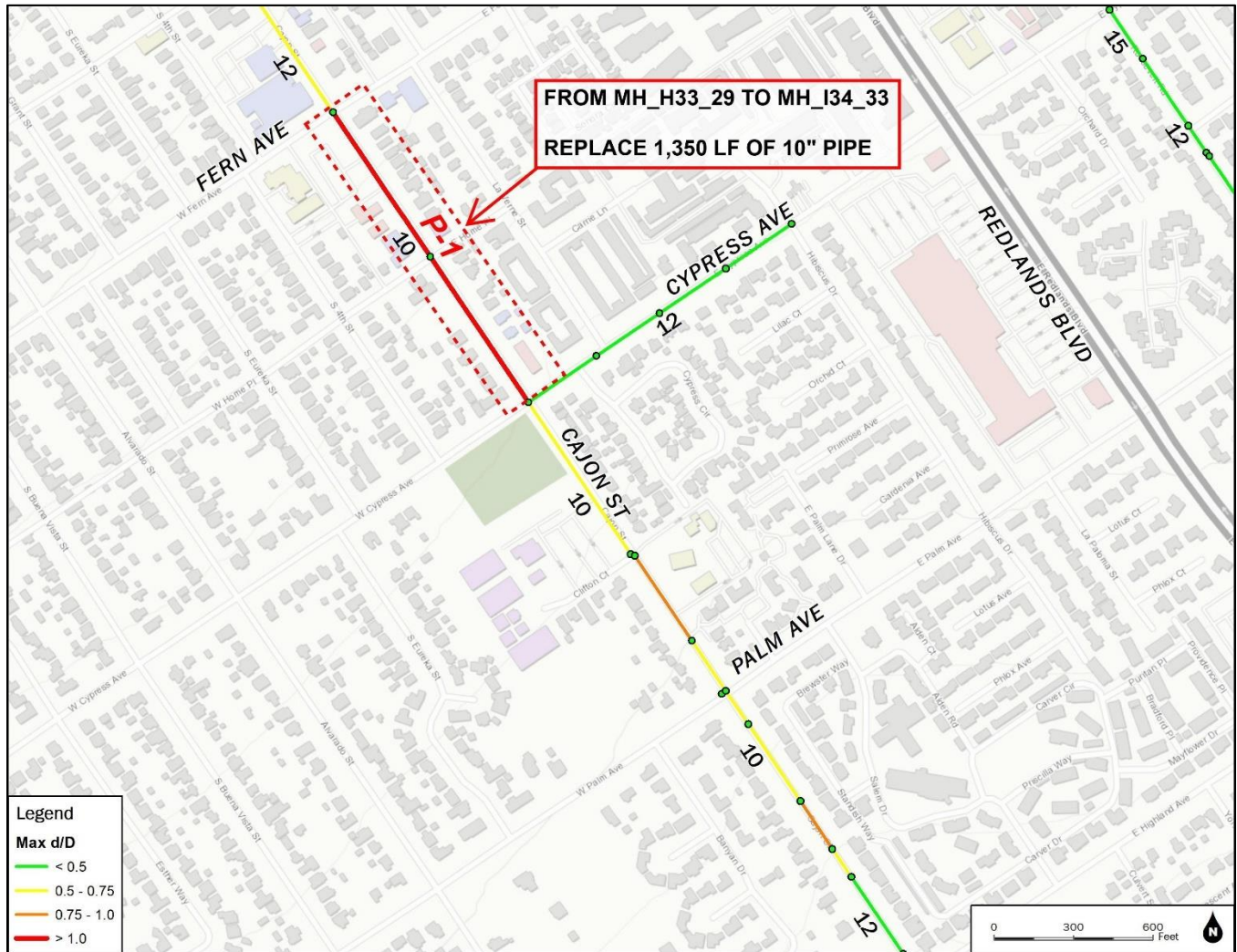

Figure 4.5: Cajon St (South of E Citrus Ave) Capacity Evaluation

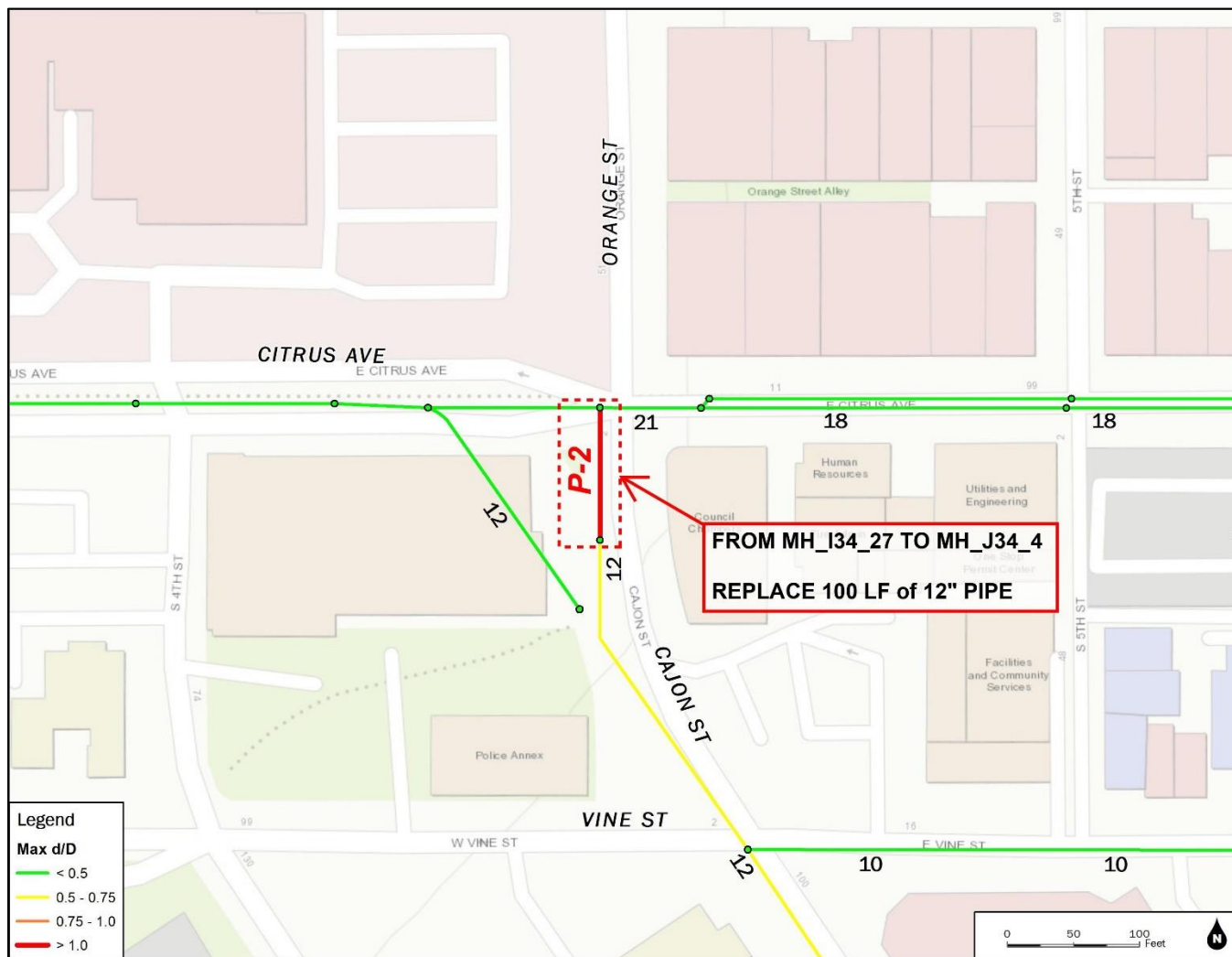
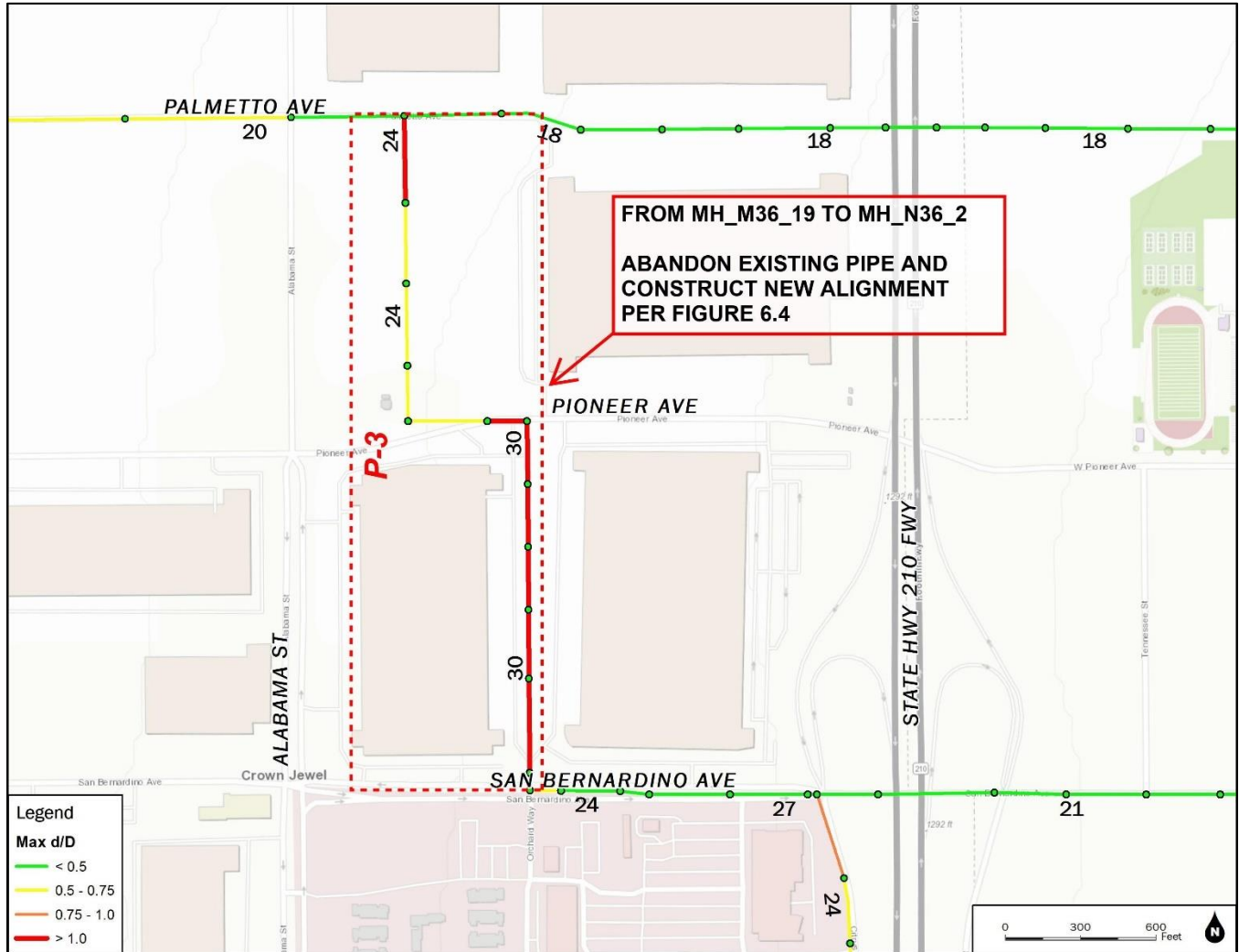

Figure 4.6: Alley East of Alabama St (Between San Bernardino Ave and Palmetto Ave) Capacity Evaluation



4.4.2 Near-Term (2030) Flows Capacity Evaluation

The existing (2020) capacity improvements listed in Table 4.3 were incorporated into the collection system, and a capacity analysis was performed under near-term (2030) peak wet weather flow loading conditions. An EPS was run on the system. Maximum depth over diameter (d/D) ratios for all pipes were compared against the d/D of 1.0 trigger criteria discussed in Section 4.2. Results of the near-term (2030) PWWF analysis with existing (2020) improvements are presented in **Figure 4.7**. These results indicate that three (3) additional reaches, beyond those identified in the existing (2020) PWWF scenario, exceeded the trigger criterion of d/D of 1.0, as shown in **Figures 4.8, 4.9 and 4.10**. As with the existing (2020) evaluation, the recommended upsizing for the pipes listed in **Table 4.4** were analyzed under buildout (2070) PWWF conditions and found to meet the gravity main criteria in Table 4.1.

Note: Figure 4.8 identifies an 8-inch pipe with a max d/D of 0.40 at Brockton Ave and Herald St that the City recommended for upsizing.

Note: Figure 4.7 shows a short pipe at the inlet of the collection system at the south end of Ford St exhibits a maximum d/D of 1.0 under near-term (2030) PWWF conditions. This pipe was not flagged as a capacity improvement project because the system was assumed to have all adjacent residential loads (picked up by 8-inch sewer pipes) begin at the south end of Ford St and would not take into account the peak hour dampening effect that would normally be seen in the collection system.

Table 4.4: Recommended Near-Term (2030) System Capacity Improvements

Project ID	Location	Ex. Diameter (inch)	PWWF Max d/D	Length (LF)	Recommended Upsizing (inch)
P-4	Brockton Ave at 6 th St & Herald St	8	1.0	700	10
P-5	Citrus Plaza Dr, south of San Bernardino Ave	24	1.0	350	27
P-6	Nevada St, north of Palmetto Ave	27	1.0	1,900	30
TOTAL				2,950	-

Figure 4.7: Results of Near-Term (2030) Capacity Evaluation with 2020 Improvements

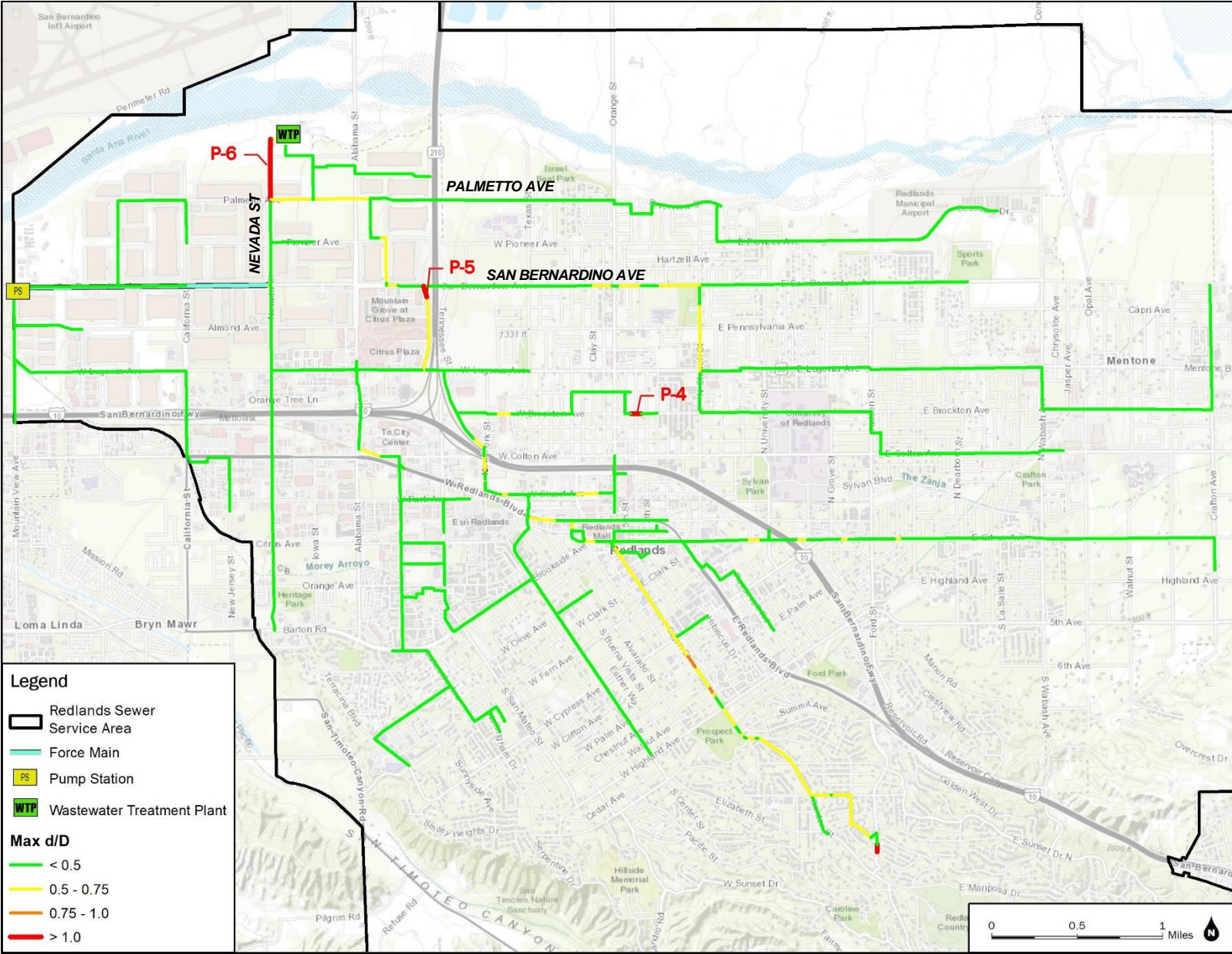

Figure 4.8: Brockton Ave at 6th St & Herald St Capacity Evaluation

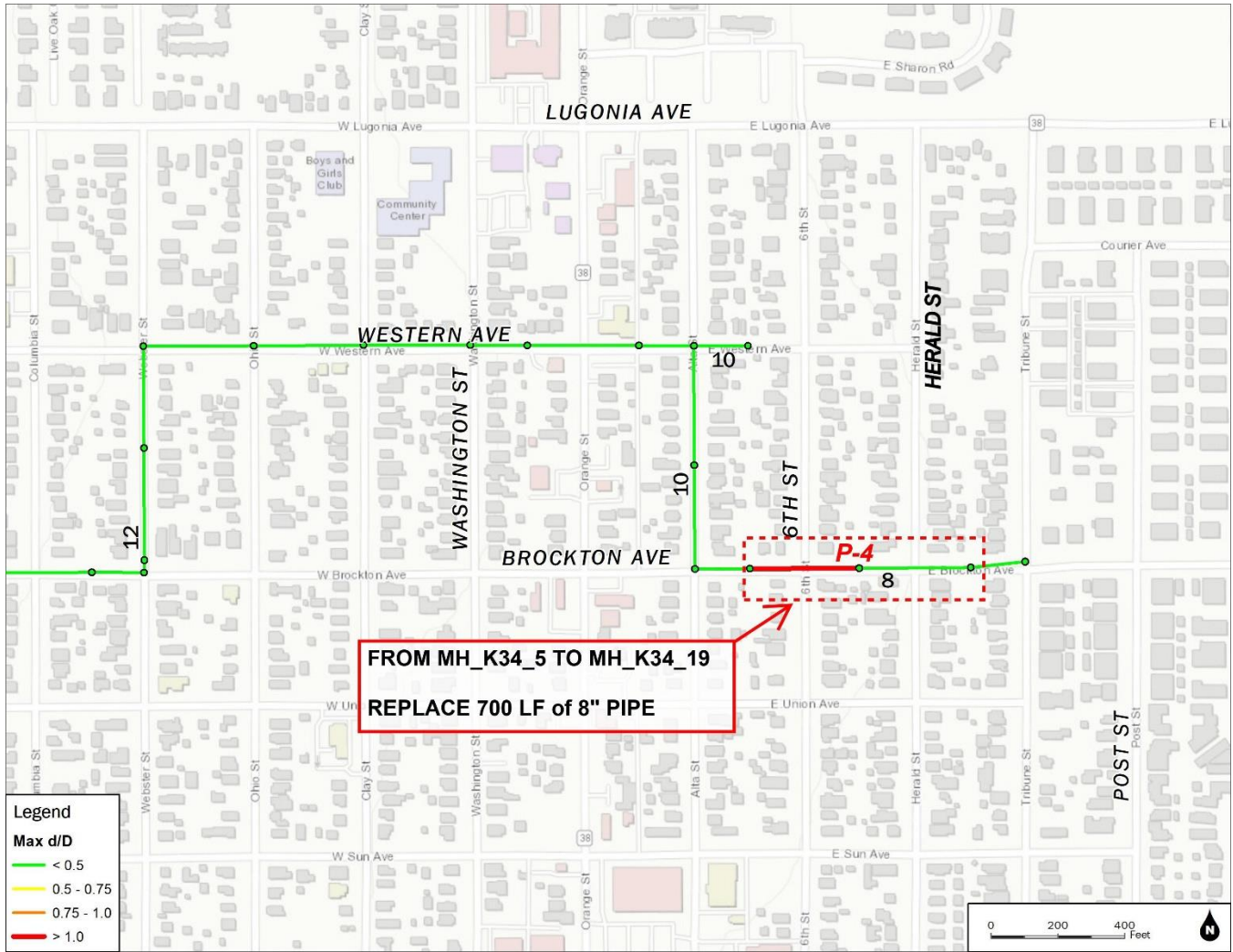

Figure 4.9: Citrus Plaza Dr (South of San Bernardino Ave) Capacity Evaluation

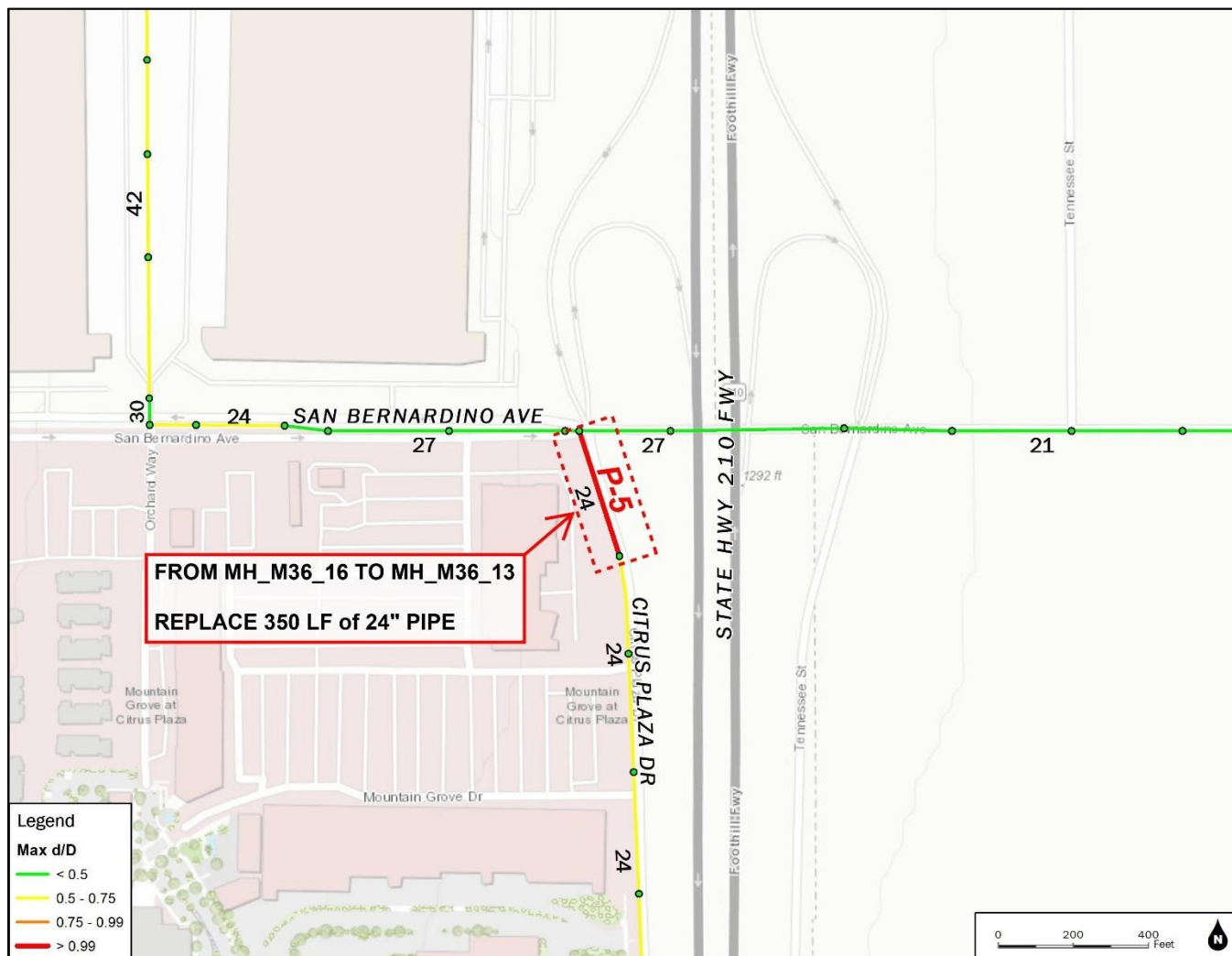
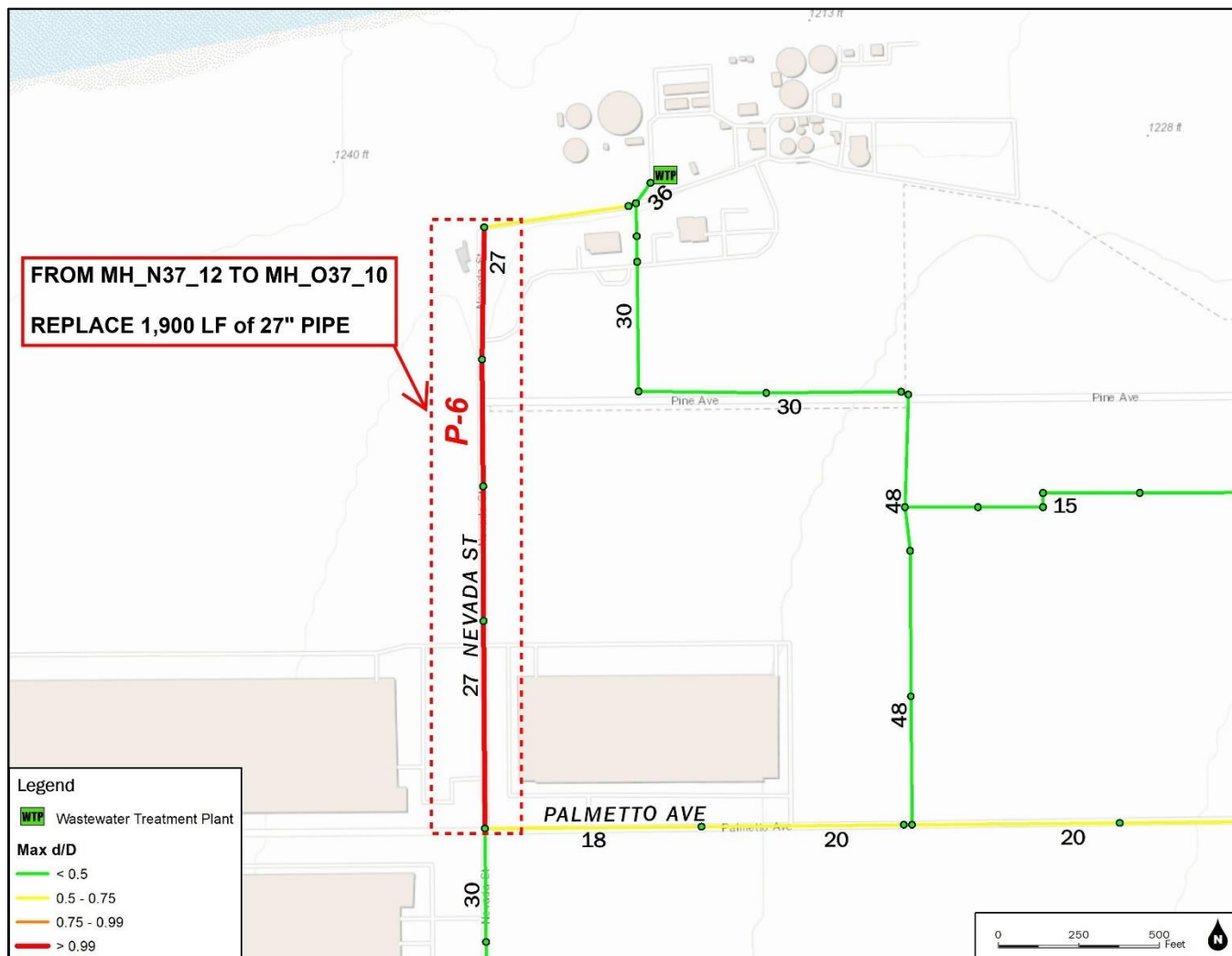

Figure 4.10: Nevada St (North of Palmetto Ave) Capacity Evaluation



4.4.3 Long-Term (2045) Capacity Evaluation

The existing (2020) and near-term (2030) capacity improvements listed in Tables 4.3 and 4.4 were incorporated into the collection system, and a capacity analysis was performed under long-term (2045) peak wet weather flow loading conditions. An EPS was run on the system. Maximum depth over diameter (d/D) ratios for all pipes were compared against the d/D of 1.0 trigger criteria discussed in Section 4.2. Results of the long-term (2045) PWWF analysis with existing (2020) and near-term (2030) capacity improvements are presented in **Figure 4.11**. These results indicate that two (2) additional reaches beyond those identified in the existing (2020) and near-term (2030) PWWF scenarios exceeded the trigger criterion of d/D of 1.0, as presented in **Figures 4.12** and **4.13**. As with the previous scenarios discussed in this section, the recommended upsizing for the pipes listed in **Table 4.5** were analyzed under buildout (2070) PWWF conditions and found to meet the gravity main criteria in Table 4.1.

Table 4.5: Recommended Long-Term (2045) System Capacity Improvements

Project ID	Location	Ex. Diameter (inch)	PWWF Max d/D	Distance (LF)	Recommended Upsizing (inch)
P-7	South Ave, between Garden St and Franklin Ave	8	1.0	300	10
P-8	Cajon St, between 600 feet north of Highland Ave and Cypress Ave	10	1.0	2,100	12
TOTAL				2,500	-

Figure 4.11: Results of Long-Term (2045) Capacity Evaluation with 2020 and 2030 Improvements

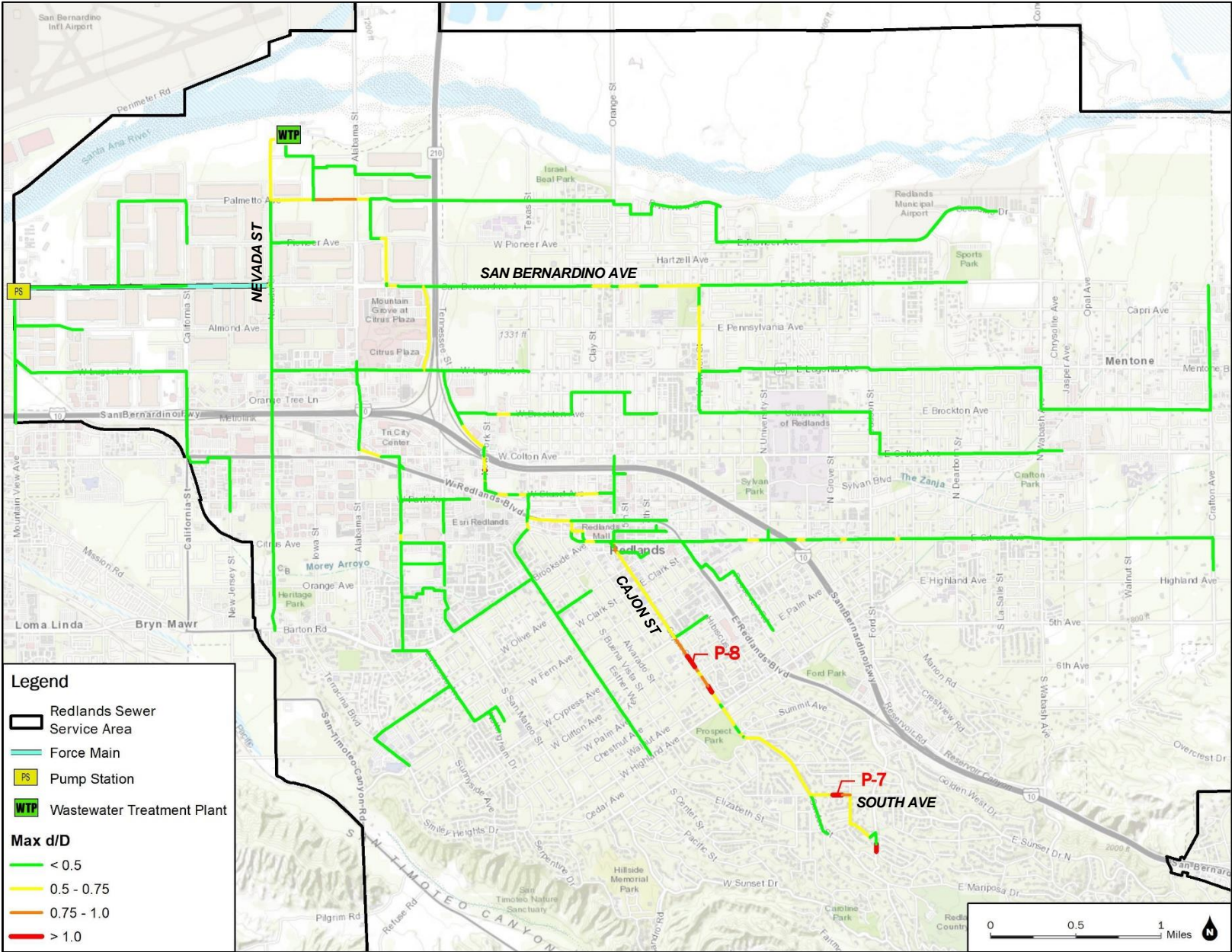

Figure 4.12: South Ave (Between Garden St and Franklin Ave) Capacity Evaluation

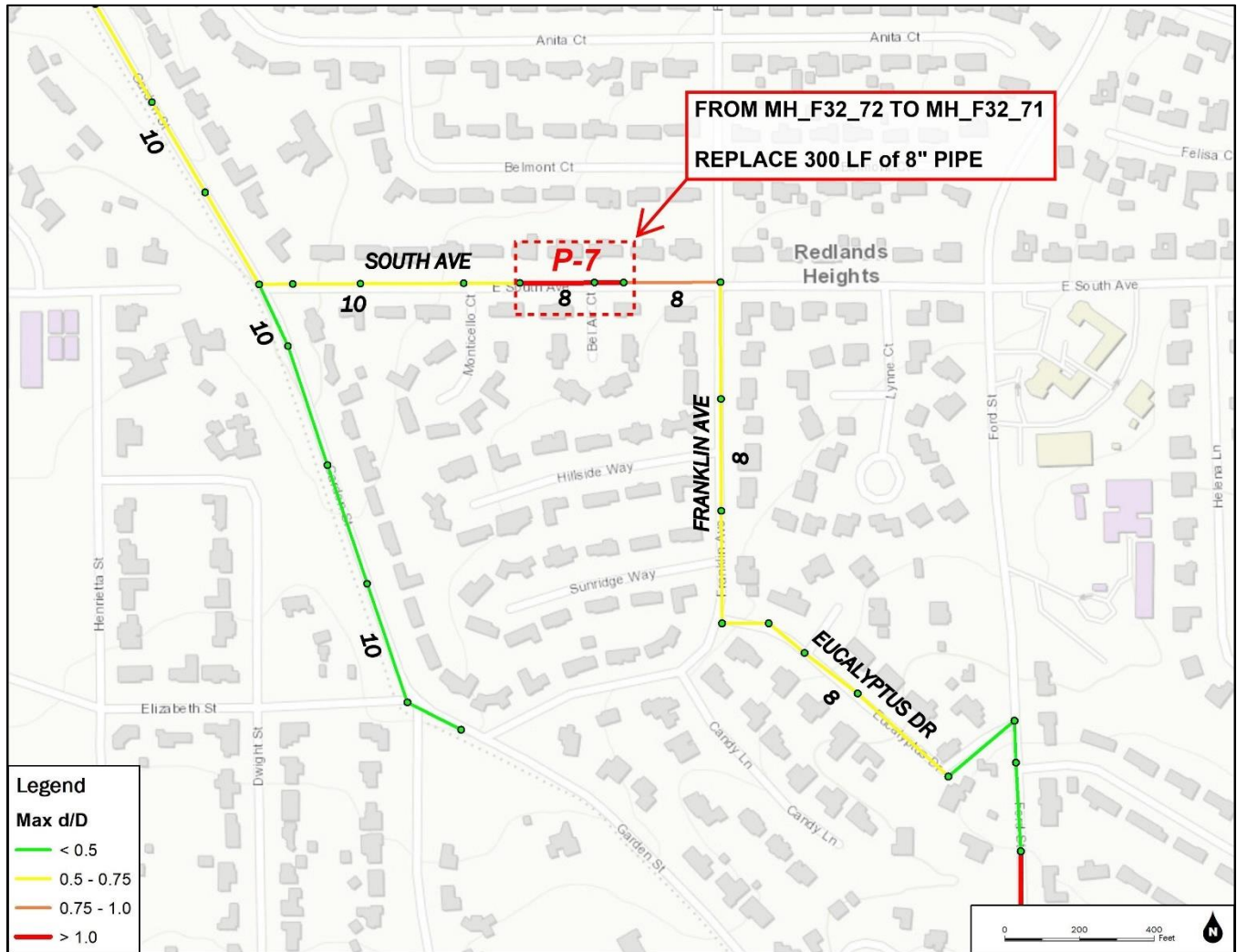
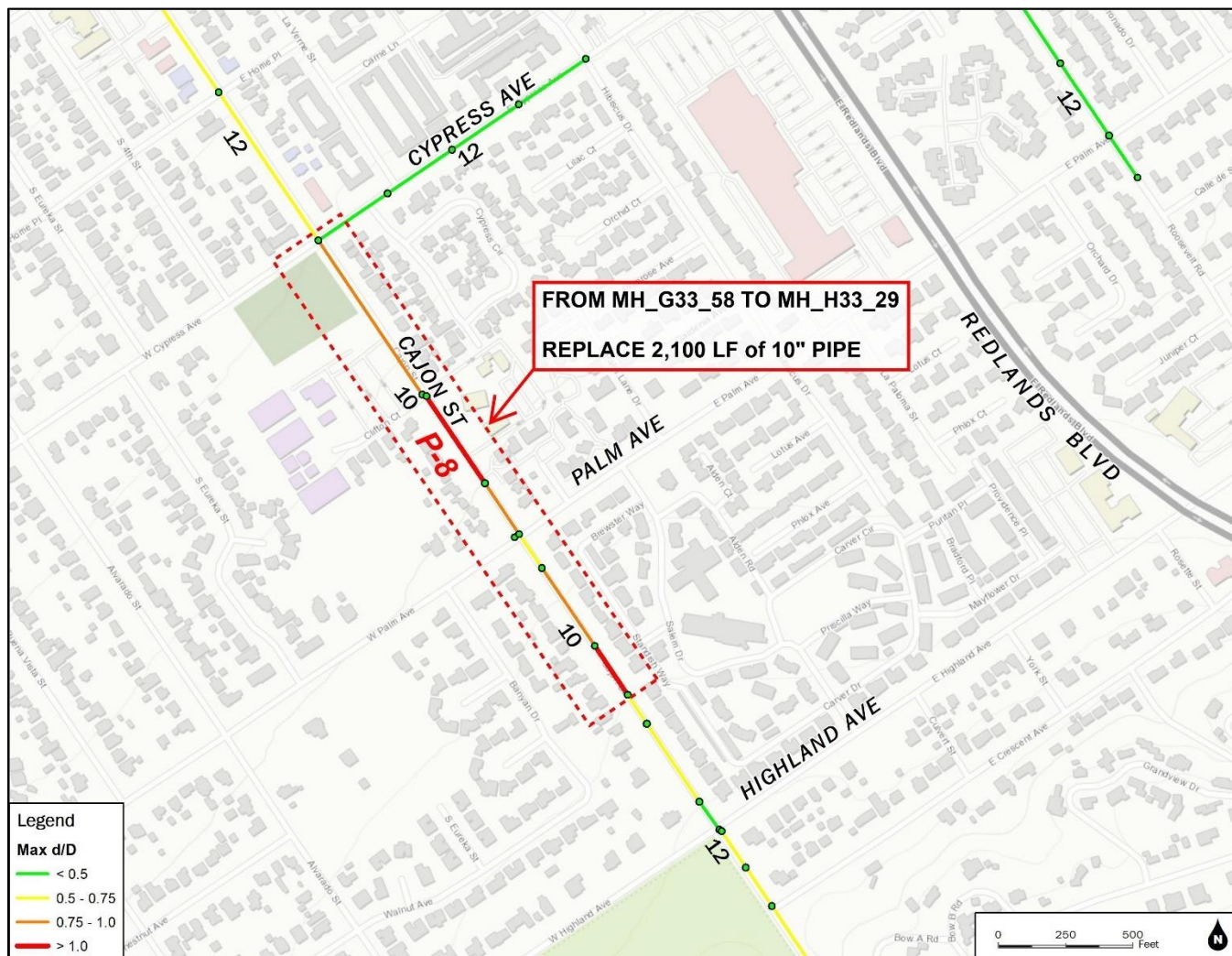

Figure 4.13: Cajon St (Between 600 feet North of Highland Ave and Cypress Ave) Capacity Evaluation



4.4.4 Buildout (2070) Flows Capacity Evaluation

The existing (2020), near-term (2030), and long-term (2045) capacity improvements listed in Tables 4.3, 4.4, and 4.5 were incorporated into the collection system, and a capacity analysis was performed under anticipated buildout (2070) peak wet weather flow loading conditions. An EPS was run on the system. Maximum depth over diameter (d/D) ratios for all pipes were compared against the d/D of 1.0 trigger criteria discussed in Section 4.2. Results of the buildout (2070) PWWF analysis with existing (2020), near-term (2030), and long-term (2045) capacity improvements are presented in **Table 4.6** and **Figure 4.14**. These results indicate that two additional pipelines beyond those identified in the previous PWWF scenarios exceeded the trigger criterion of d/D of 1.0, as presented in more detail in **Figures 4.15** and **4.16**.

Table 4.6: Recommended Buildout (2070) System Capacity Improvements

Project ID	Location	Ex. Diameter (inch)	PWWF Max d/D	Distance (LF)	Recommended Upsizing (inch)
P-9	South Ave at Franklin Ave	8	1.0	300	10
P-10	Cajon St, north of Vine St	12	1.0	300	15
TOTAL				600	-

Figure 4.14: Results of Buildout (2070) Capacity Evaluation with 2020, 2030, and 2045 Improvements

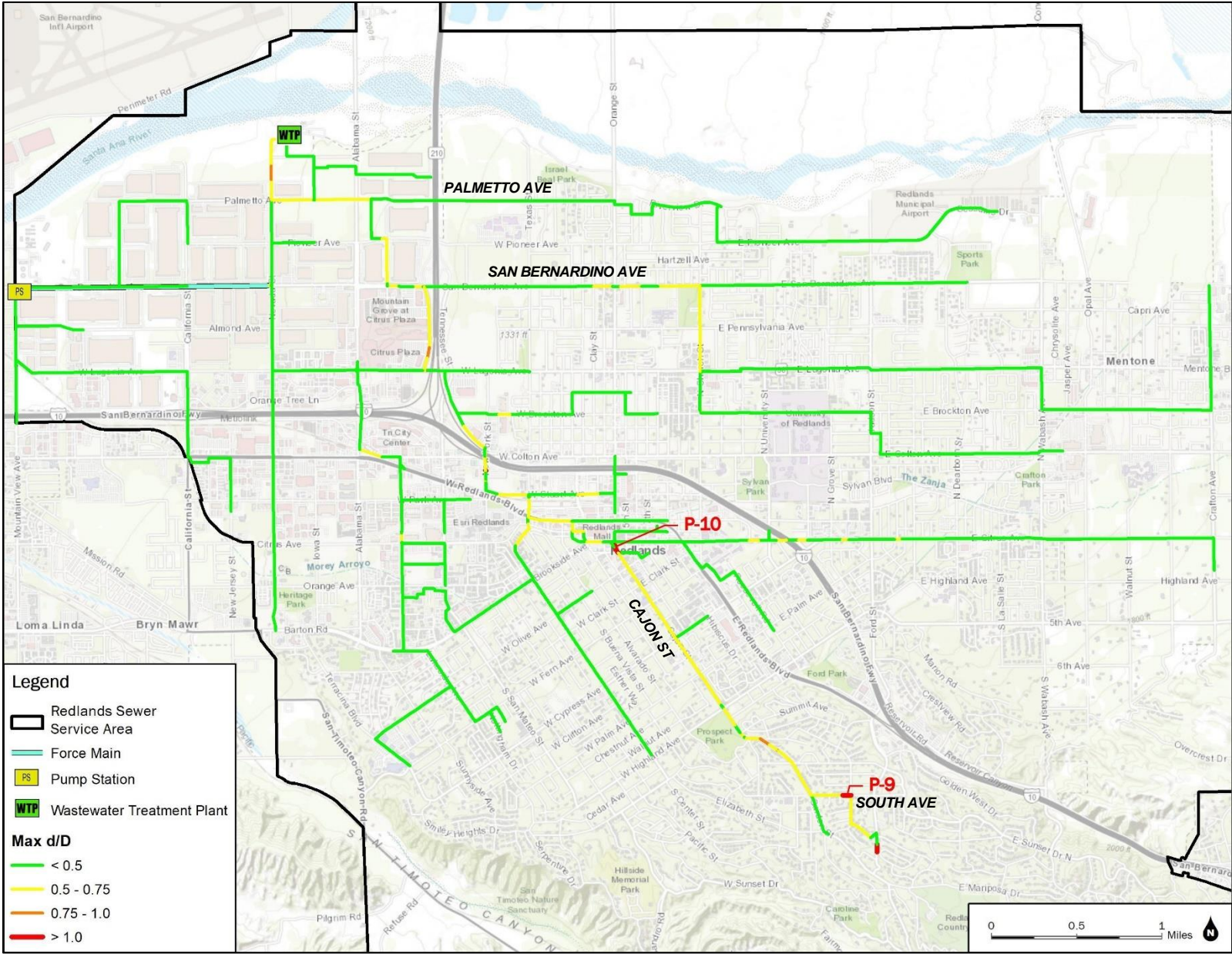

Figure 4.15: South Ave at Franklin Ave Capacity Evaluation

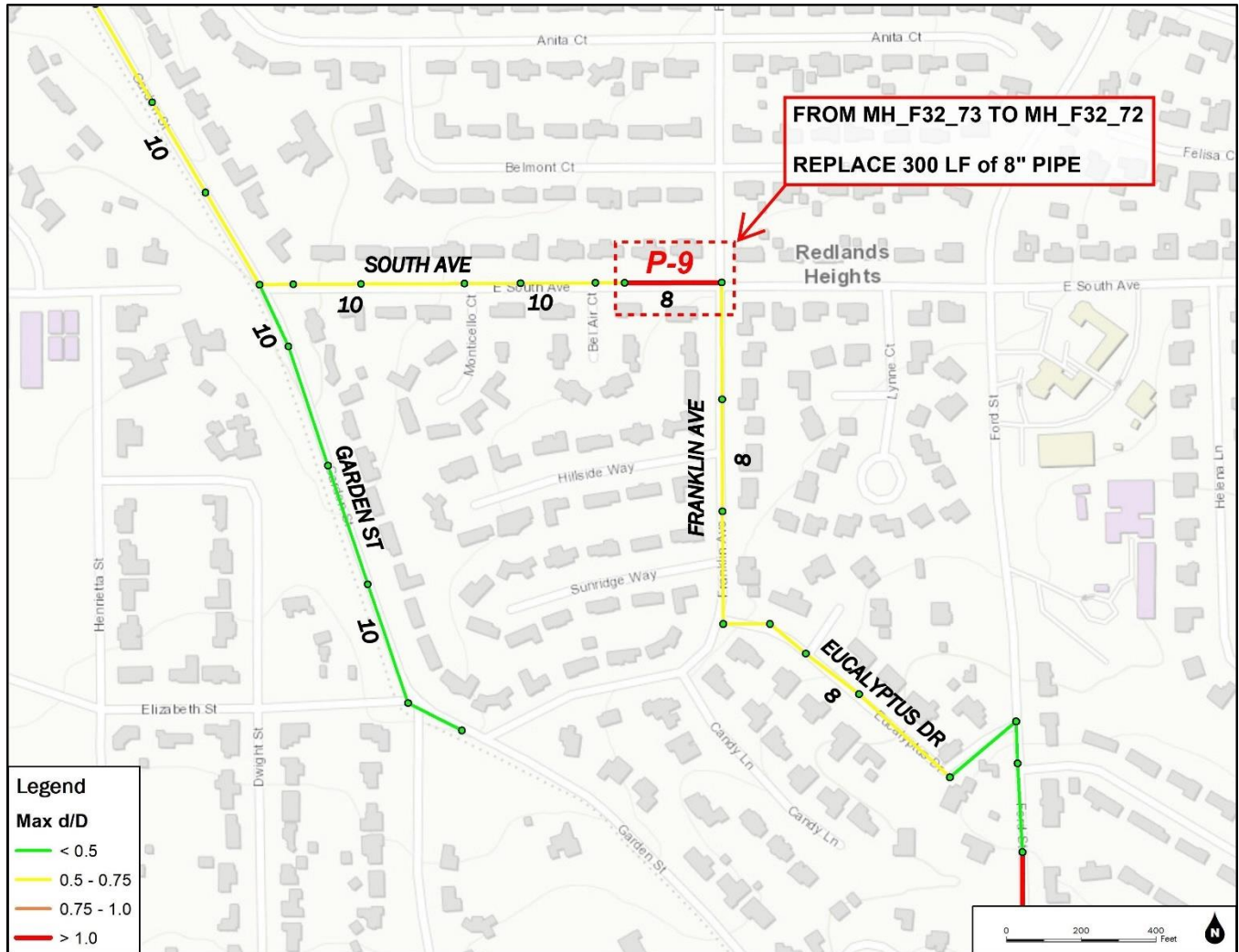
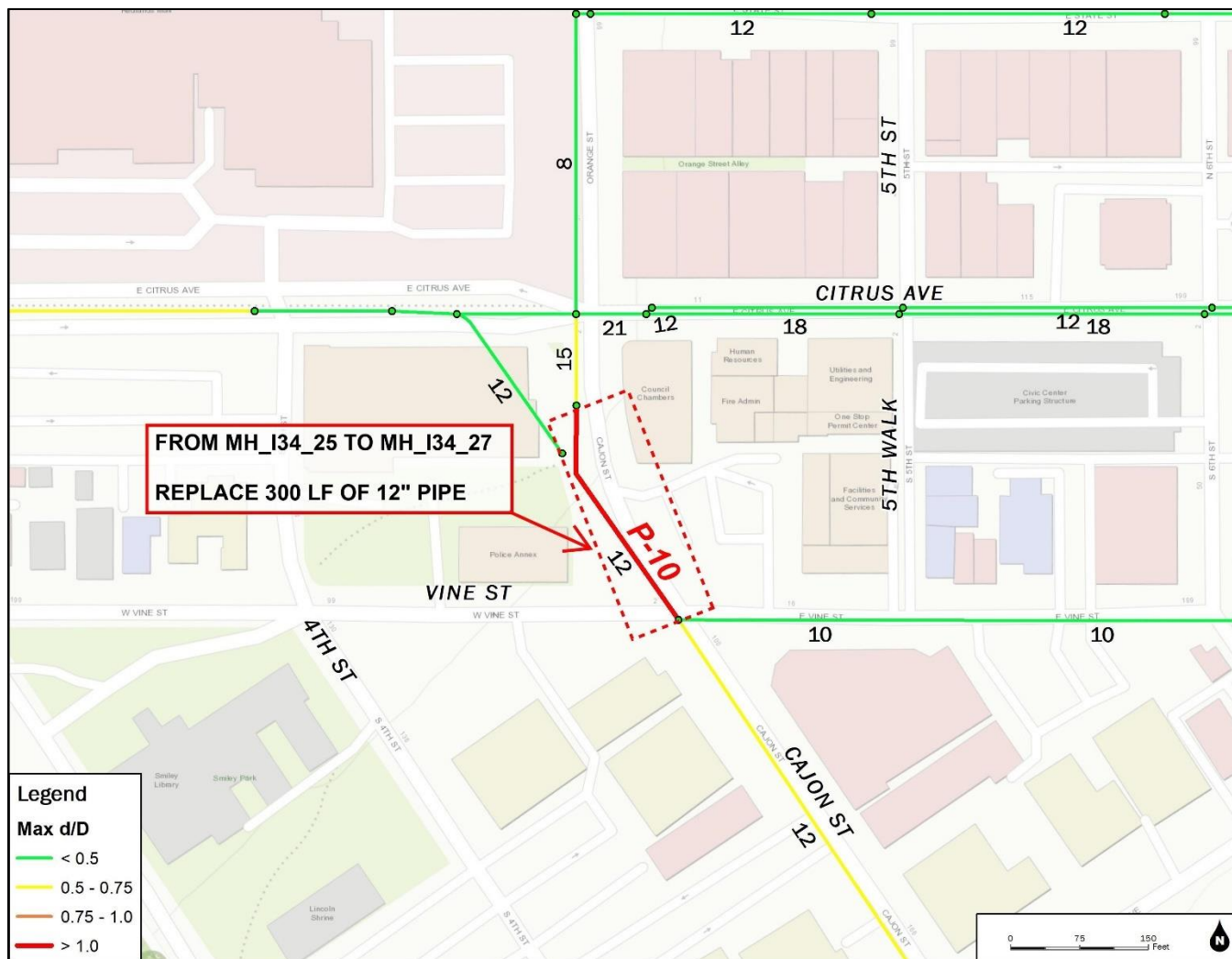

Figure 4.16: Cajon St at Vine St Capacity Evaluation



4.4.5 Lift Station and Forcemain Analysis

The San Bernardino/Mountain View lift station has two (2) pumps, each with a design point of 4.0 MGD at 140 feet, a 0.057 MG wet well and a hookup for a portable backup generator. A capacity analysis was performed for the lift station pumps and wet well based on the criteria listed in Table 4.1, as presented in **Tables 4.7** and **4.8**. The pump capacity analysis compared existing firm pump capacity of the lift station to the projected PWWF influent into the lift station, based on the hydraulic model. The firm capacity of the lift station is the capacity with the largest pump taken out of service. The model results presented in Table 4.7 indicate that with the largest pump out of service, the San Bernardino/Mountain View lift station is capable of handling PWWF throughout buildout of the system.

When the pump is in operation, flow through the 12-inch forcemain produces a velocity of 4.2 fps. Flow through the 14-inch forcemain produces a velocity of 3.7 fps. Both the 12-inch and 14-inch forcemain velocities fall within the 2.5 to 8 fps velocity requirements listed in Table 4.1.

Per the design criteria in Table 4.1, the lift station wet well should ideally have sufficient emergency volume to accommodate 6 hours of ADWF. Emergency volume is defined as the volume of wet well capacity between the maximum high-water level of the wet well (18-ft depth) and lag pump on setting (12-ft depth). As presented in Table 4.8, the existing wet well does not meet the design criteria for emergency storage of 6 hours of ADWF; however, in the event of a power outage, there is an existing overflow discharge pipe that can convey excess sewage flow from the San Bernardino/Mountain View lift station to the San Bernardino Wastewater Facility. Currently, the wet well provides approximately 2.5 hours of emergency storage. As development continues, that storage duration is projected to drop to approximately 1.5 hours.

Table 4.7: PWWF San Bernardino/Mountain View Lift Station Capacity Analysis

Model Scenario Timeframe	Capacity (MGD)		Total Capacity		Firm Capacity		PWWF (MGD)	Capacity Deficient
	Pump No. 1	Pump No. 2	(gpm)	(MGD)	(gpm)	(MGD)		
Existing (2020)	4.0	4.0	5,556	8.0	2,778	4.0	0.41	No
Near-Term (2030)	4.0	4.0	5,556	8.0	2,778	4.0	0.50	No
Long-Term (2045)	4.0	4.0	5,556	8.0	2,778	4.0	0.55	No
Buildout (2070)	4.0	4.0	5,556	8.0	2,778	4.0	0.57	No

Table 4.8: ADWF San Bernardino/Mountain View Wet Well Capacity Analysis

Model Scenario Timeframe	Total Wet Well Volume ¹ (MG)	Operational Volume ² (MG)	Emergency Volume ³ (MG)	ADWF (MGD)	Required Emerg. Storage Capacity ⁴ (MG)	Emerg. Volume Deficiency (gal)	Duration of Emerg. Storage Provided (hrs)	Capacity Deficient ⁵
Existing (2020)	0.045	0.025	0.02	0.19	0.05	27,500	2.5	Yes
Near-Term (2030)	0.045	0.025	0.02	0.30	0.08	55,000	1.6	Yes
Long-Term (2045)	0.045	0.025	0.02	0.32	0.08	60,000	1.5	Yes
Buildout (2070)	0.045	0.025	0.02	0.33	0.08	62,500	1.5	Yes

Notes:

¹ Total Wet well volume is based on maximum high-water elevation of 1,087.6 ft indicated on wet well as-built.

² Operational volume includes the volume below the lag pump on setting of 12 ft.

³ Emergency storage is calculated as total wet well volume minus the operational volume.

⁴ Required emergency storage capacity is 6 hours of ADWF per Table 4.1

⁵ In the event of a power outage, excess sewage above the wet well emergence volume will be discharge to the existing wet well overflow pipe.

There may be an opportunity for optimization of this lift station. The City currently operations the pumps at a reduced speed (approximately 62.5%), which is not efficient; smaller pumps may be warranted. An optimization study may demonstrate opportunities for the City to improve lift station operation and reduce costs.

4.4.6 Capacity Analysis Summary

The following **Table 4.9** summarizes the existing and projected sewer flows at the wastewater treatment plant under both dry and wet weather conditions.

A summary of the recommended improvements for each phase of capacity evaluation are summarized in **Table 4.10** and shown graphically in **Figure 4.17**. Note: Due to model calibration being based only on the WWTP influent flow meter rather than system-wide flow monitoring, it is recommended the City conduct a system-side flow program to confirm capacity restrictions are occurring.

Table 4.9: Existing and Projected Sewer Flows

Year	ADWF (MGD)	PDWF (MGD)	AWWF (MGD)	PWWF (MGD)
2020	5.8	8.1	6.5	12.0
2030	6.9	10.4	7.6	12.9
2045	7.7	10.9	8.4	14.2
2070	8.0	11.6	8.7	15.0

Table 4.10: Summary of Recommended System Capacity Improvements (All Phases)

Phase	Project ID	Location	Ex. Diameter (inch)	Distance (LF)	Recommended Upsizing (inch)
Existing (2020)	P-1	Cajon St, from Fern Ave to Cypress Ave	10	1,350	12
	P-2	Cajon St, south of E Citrus Ave	12	100	15
	P-3	Palmetto Ave to San Bernardino Ave, east of Alabama St	24 and 30	3,100	42
Near-Term (2030)	P-4	Brockton Ave at 6 th St & Herald St	8	700	10
	P-5	Citrus Plaza Dr, South of San Bernardino Ave	24	350	27
	P-6	Nevada St, north of Palmetto Ave	27	1,900	30
Long-Term (2045)	P-7	South Ave, between Garden St and Franklin Ave	8	300	10
	P-8	Cajon St, between 600 feet north of Highland Ave and Cypress Ave	10	2,100	12
Buildout (2070)	P-9	South Ave at Franklin Ave	8	300	10
	P-10	Cajon St, North of Vine St	12	300	15
TOTAL				10,500	-

Figure 4.17: Recommended Capacity Improvements (All Phases)

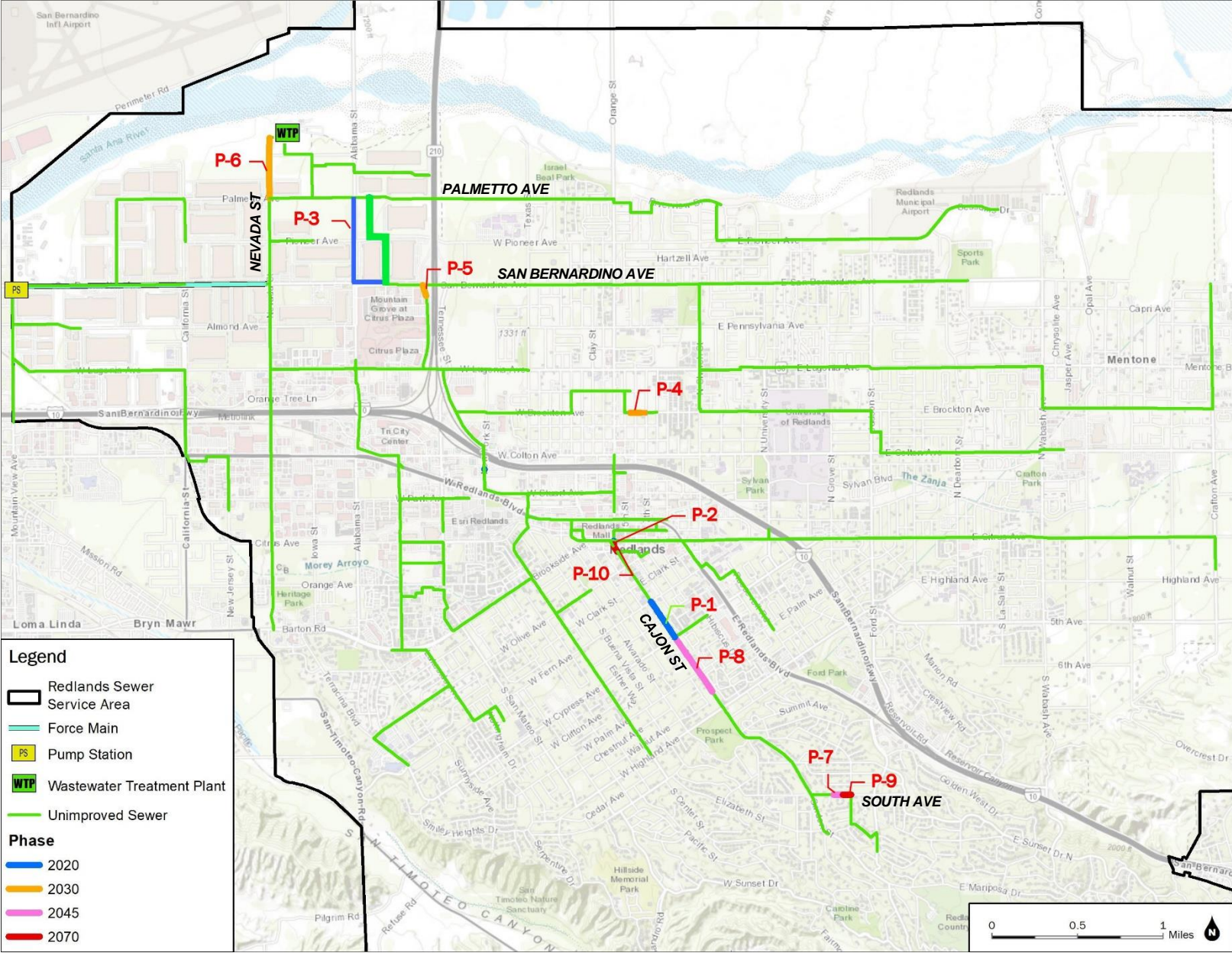

INTENTIONALLY LEFT BLANK

5 WWTP Process Evaluation

The City's collection system conveys raw wastewater to the City's WWTP for treatment. The plant was originally constructed in 1962 and has been upgraded several times, most recently in 2021. At the time of this report, the City is in the process of design and construction of another round of major process upgrades at the WWTP to improve facility reliability and performance.

In this section, a high-level WWTP treatment processes evaluation is performed with a focus on near-, mid-, and long-term capacity. Individual unit process capacities are evaluated under current loading conditions as well as for loadings at the planning horizons detailed in **Section 4**. Results from the evaluation are intended to assist the City to determine potential near-term, long-term, and buildout upgrade needs and operations & maintenance (O&M) considerations for the WWTP. Information regarding existing WWTP infrastructure and operating conditions was obtained from the record drawings, data provided by the City, the 2020 Task 1 Comprehensive Condition Assessment Final Report, and City staff input.

The section is organized as follows:

- Process overview
- Summary of regulatory permits
- Individual unit process performance evaluation
- Effective capacity evaluation
- 72-hour power outage evaluation
- Potential sites for future WWTP expansion
- Cost benefit analysis for the use of digester gas and landfill gas in cogeneration system

5.1 Process Overview

The City of Redlands WWTP system provides for the collection, treatment, and disposal of municipal sewage. The system was constructed in 1962 and the most recent facility rehabilitation occurred in 2003. The WWTP has a permitted annual average flow of 9.5 million gallons per day (MGD). Currently, the WWTP operates two parallel treatment systems, a membrane bioreactor (MBR) process with the capability to produce up to 6.0 MGD of recycled water and a conventional activated sludge (CAS) process with a capacity of 3.5 MGD. Typical influent average daily flow is approximately 6 MGD.

The WWTP treatment process consists of preliminary, primary, secondary treatment (conventional activated sludge system and MBR), chlorine contact disinfection used only for the MBR system to achieve disinfected secondary 2.2 recycled effluent, as defined by the California Code of Regulations Title 22. The MBR secondary effluent is provided to the Mountainview Power Company to serve as recycled water for cooling towers and to a nearby landfill for dust control. Effluent is also used by other approved downstream users for irrigation and agricultural users. Excess recycled water is sent to the effluent pump station and co-mingles with the secondary CAS effluent before being discharged to the percolation ponds. The secondary CAS effluent is discharged to percolation ponds without being disinfected. Sludge wasted from the primary and secondary clarifiers, is thickened in Dissolved Air Floatation Tanks (DAFTs), digested in anaerobic digesters, and then dewatered using centrifuges. The WWTP process flow diagram and site layout are shown in **Figure 5.1**, **Figure 5.2** and **Figure 5.3**, respectively.

Figure 5.1: Liquids Process Flow Diagram

Courtesy of Task 1 Comprehensive Condition Assessment Final Report, October 2020.

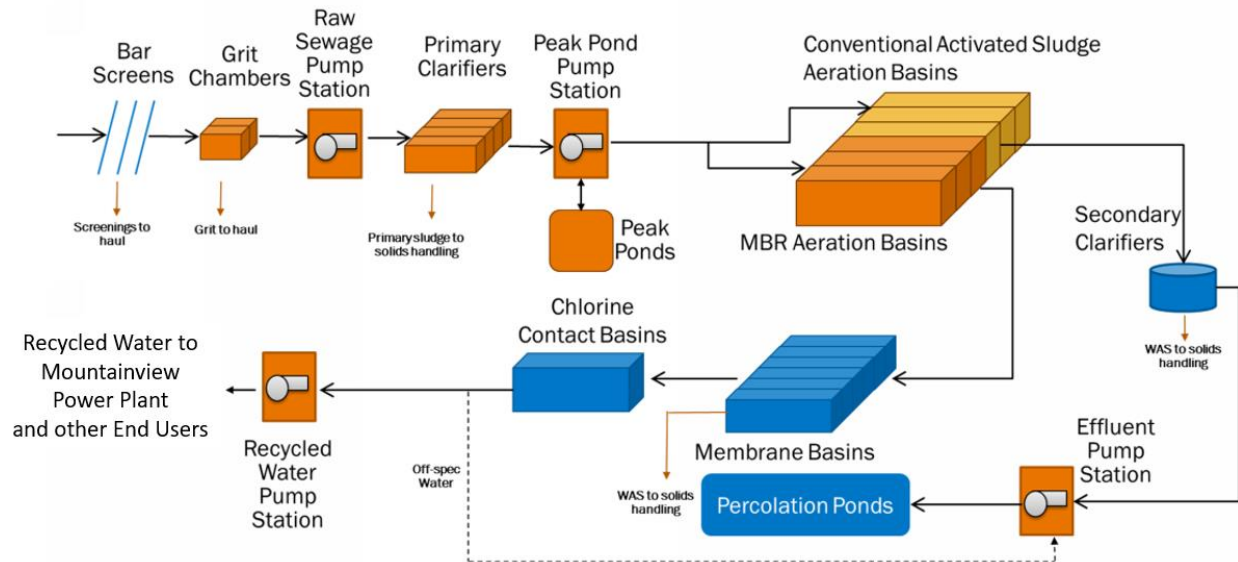

Figure 5.2: Solids Process Flow Diagram.

Courtesy of Task 1 Comprehensive Condition Assessment Final Report, October 2020.

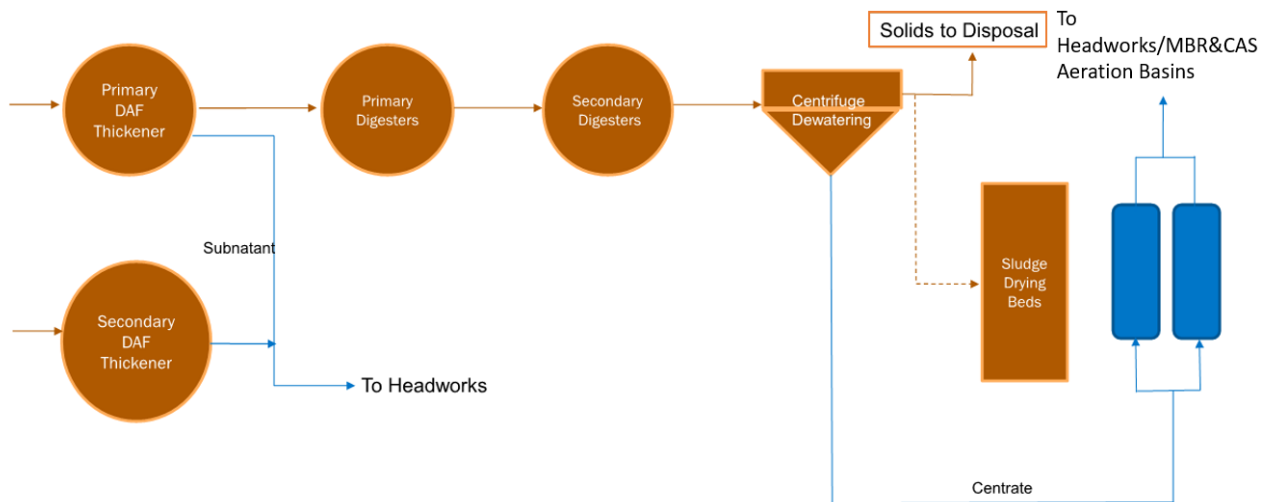
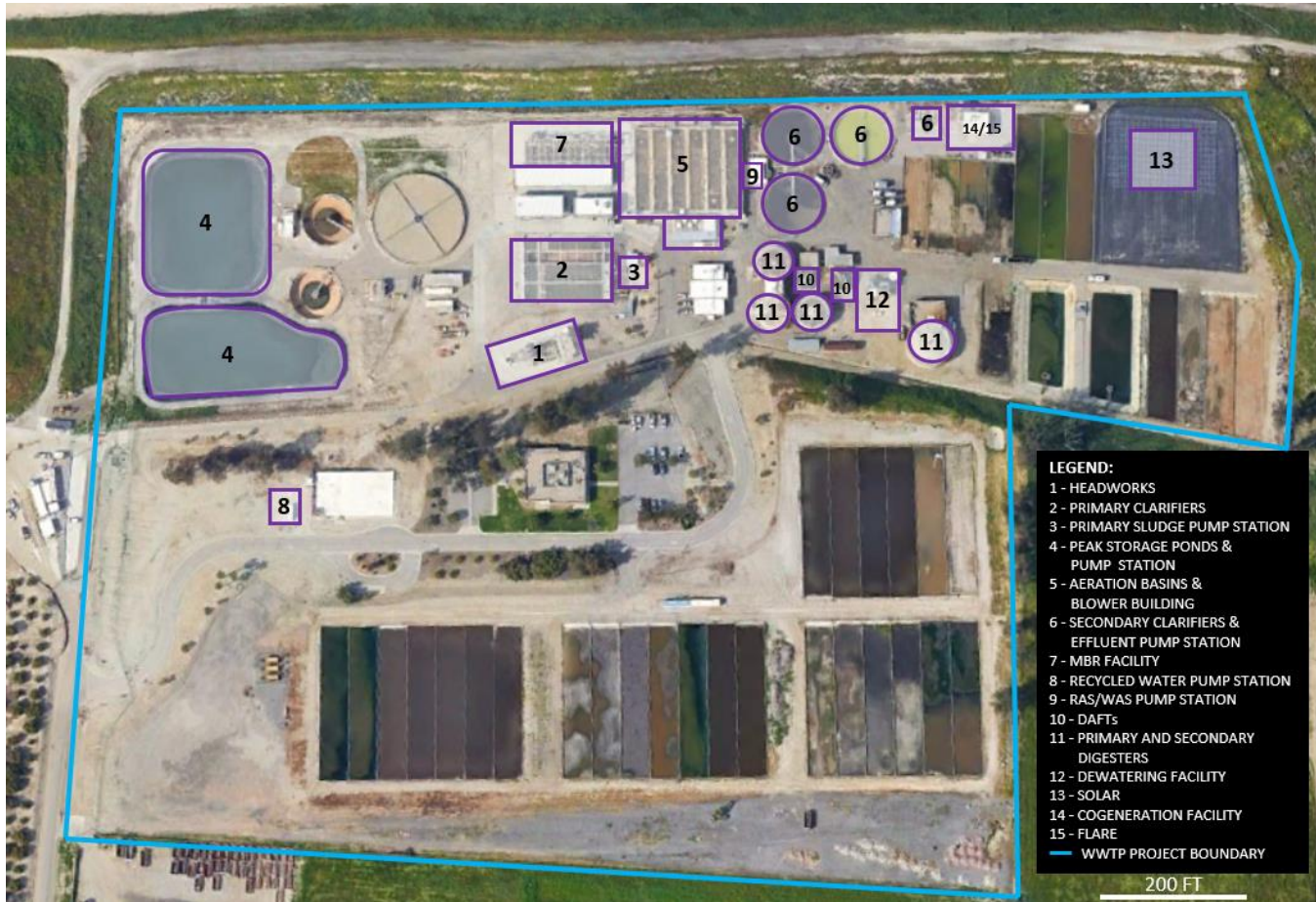

Figure 5.3: Existing WWTP Site Layout.



5.1.1 Previous Studies

The project team was provided with the following previous report, record drawings, and other relevant records from the City for review. **Table 5.1** details the name, brief description, and year of the previously completed study.

Table 5.1: Summary of Previous Report

Document Name	Description
<p>City of Redlands: Task1 Comprehensive Condition Assessment Final Report</p> <p>Year Completed: 2020</p>	<p>Contents: In October 2020, the City performed a comprehensive condition assessment evaluation of the wastewater treatment unit operations, equipment, aboveground pipelines, electrical, instrumentation and controls, structural, civil, and subsurface utilities components of the WWTP. The assessment identified key treatment process performance parameters and capacities, as well as the remaining lifetime of the existing unit treatment processes before performing any major upgrades. Additionally, it was determined that the conventional treatment process will be phased out and the MBR system will be expanded during the second phase of plant upgrades.</p>

5.2 Summary of Regulatory Permits

The WWTP is regulated by two sets of permits: the Waste Discharge and Producer/User Water Recycling Requirements (WDRs), Board Order No. R8-2006-0008 and Mountainview Power Company Discharge Requirements. The WDR permit includes discharge requirements for conventional effluent which is discharged to the percolation ponds as well as for the reclaimed effluent used for recycled water by the Mountainview Power Company. The Mountainview Power Company imposes additional requirements for recycled water which are stricter than the WDR recycled water requirements. The WDR and Mountainview Power Company permits are detailed in **Table 5.2** and **Table 5.3**, respectively.

Table 5.2: Conventional and Recycled Water Effluent Discharge Requirements

Parameter	Units	Conventional Effluent	Recycled Water ¹	Notes
BOD ₅	mg/L	30	20	Avg. Monthly
	mg/L	-	30	Avg. weekly
TSS	mg/L	30	20	Avg. monthly
	mg/L	-	30	Avg. weekly
pH	std units	6-9	6-9	Instantaneous min. - Instantaneous max.
TDS	mg/L	440 or water supply + 250	440	-
TIN	mg/L	10	-	12-month flow weighted running avg.
Turbidity	NTU	-	0.2	More than 5% of the time in any 24-hr period
	NTU	-	0.5	Any time
Coliform	MPN/100 mL	-	2.2	Weekly avg.
	MPN/100 mL	-	23	More than one sample in any 30-day period
	MPN/100 mL	-	240	Any time
CCB CT	mg-min/L	-	450	-
CCB Modal Contact time	min	-	90	Peak dry weather design flow

Notes:

¹ Based on City of Redlands Wastewater Treatment Plant "Task 1 Comprehensive Condition Assessment Final Report - October 2020"

Table 5.3: Mountainview Power Company Discharge Requirements

Parameter	Units	Recycled Water ¹	Notes
BOD ₅	mg/L	<5	90% of the time
	mg/L	<10	100% of the time
TSS	mg/L	<2	90% of the time
	mg/L	<5	100% of the time
pH	mg/L	6-8.5	Instantaneous Min. - Max.
TDS	mg/L	<500	-
NH ₃ -N	mg/L	<1	90% of the time
	mg/L	<2	100% of the time
TIN	mg/L	<12	-
COD	mg/L	<35	90% of the time
	mg/L	<45	100% of the time
PO ₄	mg/L	<4	90% of the time
	mg/L	<5	100% of the time
Silica	mg/L	<25	90% of the time
	mg/L	<30	100% of the time
Coliform	MPN/100 mL	2.2	Weekly Avg.
	MPN/100 mL	23	More than one sample in any 30-day period
Chlorine residual	mg/L	0.5	Min.
	mg/L	5	Spiking
Temperature	degrees F	<90	-

Notes:

¹Based on City of Redlands Wastewater Treatment Plant "Task 1 Comprehensive Condition Assessment Final Report - October 2020"

5.3 Process Performance and Capacity Evaluation

This section summarizes individual unit process performance and capacity. Unit process performance is evaluated by analyzing process flowrates and water quality data and comparing the data to both plant design criteria and typical industry ranges. In addition, process capacities and deficiencies at current and future conditions are evaluated to identify plant reliability.

5.3.1 Individual Unit Process Performance

A process performance overview for the WWTP is provided in **Table 5.4**. Average values of the data are provided as available, along with design criteria, M&E typical ranges, and regulatory limits. Data was obtained between September 2019 and August 2020 unless otherwise noted. Design criteria were taken from the process capacity evaluation performed by Parsons in October 2020.

Table 5.4: Redlands WWTP Process Performance Summary

Parameter	Units	Value		Metcalf & Eddy Typical Range	Regulatory Limit for Conventional Effluent
		WWTP in Operation	Design Criteria ⁴		
Plant Influent					
Total Plant Influent Flowrate	MGD	6.0	9.5	-	-
Influent COD	mg/L	-	863	600 - 900	-
Influent tBOD	mg/L	-	382	200 - 400	-
Influent BOD ₅	mg/L	302	344	200 - 400	-
Influent TSS	mg/L	293	391	195 - 389	-
Influent VSS	mg/L	-	340	-	-
Influent Ammonia	mg/L	40	50	12 - 45	-
Influent TKN	mg/L	61	76	20 - 75	-
Influent Alkalinity	mgCaCO ₃ /L	-	305	200	-
Primary Treatment					
COD Removal	%	-	40%	-	-
Primary Effluent BOD	mg/L	234	-	-	-
BOD Removal	%	22%	33%	20 - 40	-
Primary Effluent TSS	mg/L	100	-	-	-
TSS Removal	%	65%	65%	45 - 65	-
Primary Effluent Ammonia	mg/L	36	-	-	-
Ammonia Removal	%	-	5% of VSS removed	-	-
Conventional Aeration Basins					
Influent Flowrate	MGD	3.3	3.5	-	-
RAS Flowrate	gpm	2,200	1,800 - 2,200	-	-
Secondary Effluent BOD	mg/L	13	-	<30	-
Secondary Effluent TSS	mg/L	9	-	-	-
MLSS	mg/L	2,200	3,000	2,000 - 4,000	-
SVI	mg/L	161	-	-	-
Ammonia	mg/L	<1	-	<3	-
Nitrate	mg/L	<9	-	-	-
TIN	mg/L	<10	-	-	-
Dissolved Oxygen (DO)	mg/L	-	-	1.5 - 2	-
MBR					
Influent Flowrate	MGD	2.8	6	-	-
BOD	mg/L	2.1	-	-	-
TSS	mg/L	0.4	-	-	-
MLSS	mg/L	7,800	8,000	6,000 - 10,000	-
SVI	mg/L	-	-	-	-
Ammonia-N	mg/L	<1	-	-	-
Nitrate	mg/L	<8	-	-	-
TIN	mg/L	-	-	-	-

Table 5.4: Redlands WWTP Process Performance Summary

Parameter	Units	Value		Metcalf & Eddy Typical Range	Regulatory Limit for Conventional Effluent
		WWTP in Operation	Design Criteria ⁴		
Secondary Clarifiers					
Sludge Blanket	ft	-	2	-	-
Chlorine Disinfection for MBR					
Flowrate	MGD	2.8	6.6	-	-
Chlorine Residual (Plant Effluent)	mg/L	-	-	-	0.5 / 5
MBR Turbidity	NTU	<1.0	-	-	2 / 5 / 10
Effluent to Percolation Ponds (CAS)					
Effluent Flowrate	MGD	3.3	3.5	-	-
Effluent TSS	mg/L	8.8	-	30 / 45	30
Effluent VSS	mg/L	-	-	-	-
Effluent COD	mg/L	-	-	-	-
Effluent BOD ₅	mg/L	13.5	-	25 / 40	30
Effluent NH ₃	mg/L	1.8	-	-	-
pH	std units	-	-	6.0 – 9.0	6.0 – 9.0
Effluent TDS	mg/L	-	-	-	440 or water supply +250
Effluent TIN	mg/L	-	-	-	10
Turbidity	NTU	-	-	75 / 100 / 225	-
Reclaimed Effluent from MBR (to Mountainview Power Plant)					
Effluent Flowrate	MGD	0.9	1.7	-	-
TSS	mg/L	0.4	1	-	<2 / <5
TOC	mg/L	-	5	-	-
COD	mg/L	-	10	-	<35 / <45
BOD	mg/L	2	2	-	<10
Ammonia-N	mg/L	0.2	0.04	-	<1 / <2
Nitrate	mg/L	-	8.2	-	-
TIN	mg/L	-	8.2	-	<12
PO ₄ -P	mg/L	-	1.2	-	-
Silica	mg/L	-	22.5	-	<25 / <30
PO ₄	mg/L	-	3.6	-	<4 / <5
Turbidity	NTU	-	0.1	-	2 / 5 / 10
Solids Thickening (DAFTs) and Dewatering (Centrifuges)					
Primary DAFT Thickened Solids	%	1.4	-	Up to 2	-
WAS DAFT Thickened Solids	%	4.4	-	Up to 2.5	-
Dewatering Cake Solids	%	18	-	10 – 35	-
Anaerobic Digesters					
Digester Feed Flow (avg. combined)	gpd	38,368	-	-	-
Primary Digester Temperature	degrees F	95-105	-	-	-

Table 5.4: Redlands WWTP Process Performance Summary

Parameter	Units	Value		Metcalf & Eddy Typical Range	Regulatory Limit for Conventional Effluent
		WWTP in Operation	Design Criteria ¹		
Primary Digester HRT	days	13-26 (varies)	14.5	15 days for Sludge Class B	-
Primary Digester VSS	lb/d	5,815	-	-	-
Primary Digester TS	%	0.02	-	-	-
Primary Digester Alkalinity	ppm	3,679.5	-	-	-
Primary Digester Volatile Acid / Alkalinity	-	0.01	-	-	-
Biogas Production	ft ³ /d	92,150	-	-	-
Specific Gas Production	ft ³ /lb VSS	-	-	12 - 18	-

Notes:

¹ Based on City of Redlands Wastewater Treatment Plant "Task 1 Comprehensive Condition Assessment Final Report - October 2020"

The WWTP operating parameters are shown in Table 5.5.

Table 5.5: Redlands WWTP Operating Parameters

Parameter	Units	WWTP Operation	Design Criteria ¹	Metcalf & Eddy Typical Range
Preliminary Treatment				
Number of Bar Screens Online	#	2 of 2	-	-
Avg. Design Flow per Bar Screen	MGD	3	4.8	-
Number of Grit Chambers Online	#	2 of 2	-	-
Avg. Flow per Grit Chamber	MGD	3	9.5	-
Grit Chamber Detention Time (Peak)	min	2.1	2.4	2-5
Airflow per Grit Chamber	SCFM/LF	-	-	3-8
Air Supplied to Each Chamber	SCFM/each	38	38	-
Raw Sewage Lift Station Pumps Online	#	3 of 4	-	-
Capacity, each	gpm	-	4,200	-
Primary Treatment				
Number of Clarifiers Online	#	4 of 4	4 of 4	-
Avg. Flowrate	MGD	6	9.5	-
Clarifier 1 & 2 Surface Overflow Rate (ADWF) ¹	gpd/ft ²	693	1,100	800-1200
Clarifier 3 & 4 Surface Overflow Rate (ADWF) ¹	gpd/ft ²	480	760	800-1200
Primary Sludge Thickness	ft	-	2-3	5-9
Avg. Primary Sludge Flow	gpm	20	-	-
Conventional Aeration Basins				
Number of Aeration Basins Online	#	6 of 6	6 of 6	-
Avg. Flowrate	MGD	3	3.5	-
MLSS	mg/l	2,200	3,000	2,000-4,000

Table 5.5: Redlands WWTP Operating Parameters

Parameter	Units	WWTP Operation	Design Criteria ¹	Metcalf & Eddy Typical Range
MLVSS	mg/l	1,600	2,400	1,600-3,200
Total Conventional Volume	MG	1.01	1.01	-
Anoxic Percentage of Total Volume	%	25	25	20-40
Avg. MCRT	days	14.5	7.2	3-15
F:M _{TOTAL} (MM BOD)	lb BOD/lb MLVSS/d	-	0.33	0.2-0.4
F:M _{TOTAL} (Avg. BOD)	lb BOD/lb MLVSS/d	-	0.28	0.2-0.4
Secondary Clarifiers				
Number of Clarifiers Online	#	3 of 3	-	-
Side Water Depth	ft	15	15.0	11-20
Surface Overflow Rate (ADWF)	gpd/sf	147	183.0	400-700
Solids Loading (ADWF)	lb/ft ² /h	9	14.8	24-36
Avg. RAS Flow	gpm	2,200	-	-
Avg. WAS Flow	gpm	50	35	-
MBR				
Number of Tanks Online	#	6 of 6	-	-
MLSS	mg/l	7,800	8,000	8,000-12,000
MLVSS	mg/l	6,240	6,400	4,800-8,000
Avg. Flowrate	MGD	2.8	6	-
Total MBR Aeration Volume	MG	1.01	1.01	-
Anoxic Percentage of Total Volume	%	25	25	20-40
Avg. MCRT	days	22	11	3-15
F:M _{TOTAL} (MM BOD)	lb BOD/lb MLVSS/d	-	0.21	0.2-0.4
F:M _{TOTAL} (Avg. BOD)	lb BOD/lb MLVSS/d	-	0.18	0.2-0.4
Avg. RAS Flow	gpm	8,290	-	-
Avg. WAS Flow	gpm	60	60	-
CHLORINE CONTACT BASINS				
Number of Tanks Online	#	1 of 1	-	-
Total Volume	MG	0.56	0.56	-
Avg. Flowrate	MGD	2.8	6.6	-
MBR Modal Contact Time	min	-	120	-
MBR Contact Time	mg-min/L	450	450	-
DAFT				
Number of DAFT	#	2 of 2	-	-
WAS Solids Loading Rate	lb/ft ² /h	-	0.96 ²	Up to 2
PS Solids Loading Rate	lb/ft ² /h	-	1.71 ²	Up to 2.5
ANAEROBIC DIGESTERS				

Table 5.5: Redlands WWTP Operating Parameters

Parameter	Units	WWTP Operation	Design Criteria ¹	Metcalf & Eddy Typical Range
Number of Primary Digesters ²	#	3	-	-
Primary Digester Volume (combined)	MG	0.99	0.99	-
Number of Secondary Digesters	#	1 of 1		
Secondary Digester Volume	MG	0.26	0.26	-
Primary Digesters HRT	d	13-26 (varies)	14.5	15-20
Primary Digester VS Loading Rate	lb VS/cf-d	-	0.19	Up to 0.2
Secondary Digester HRT	d	-	3.80	-
Secondary Digester VS Loading Rate	lb VS/cf-d	-	0.49	-
Temperature	F	95-105	-	85-100
Estimated Volatile Solids Destruction	%	0.3	0.5	-
Avg. Gas Production	ft ³ /d	92,150	-	-
Specific Gas Production	ft ³ /lb VSS	-	-	12-18
CENTRIFUGE				
Number of Centrifuges ¹	#	1 of 2	-	-
Digested Sludge Flow	gpm	175 ¹	190	-
Solids Loading Rate	lb/hr	-	2150	-
Notes:				
¹ Based on "Task 1 Comprehensive Condition Assessment Final Report – October 2020"				
² There is two-stage digestion process. The first stage consists of 3 primary digesters and the second stage consists of a secondary digester used as a holding tank				

5.3.2 Effective Capacity

Effective process capacity and potential deficiencies at current and future conditions are summarized in **Table 5.6**. The assessment of the existing capacity of all unit operations and components of the WWTP and design criteria are based on past studies, record drawings, review of current operations, and flow model output (see **Section 4**).

Table 5.6: Redlands WWTP Effective Capacity

Unit Process	Avg. Flow Projections (MGD)				
	ADF Permitted Capacity	Current (2019-2020)	Near-Term (2030)	Long-Term (2045)	Buildout (2070)
Headworks	9.5	6	7	7.8	8.1
Raw Sewage PS	9.5	6	7	7.8	8.1
Primary Clarifiers	9.5	6	7	7.8	8.1
Peak Ponds (Flow Equalization)	9.5	6	7	7.8	8.1
Aeration Basins (CAS)	3.5	3.25	3.25	3.25	3.25
Aeration Basins (MBR)	6	2.8	3.8	4.6	4.9
Fine Screens (not existing)	-	-	-	-	-
MBR System	6	2.8	3.6	4.4	4.8

Table 5.6: Redlands WWTP Effective Capacity

Unit Process	Avg. Flow Projections (MGD)				
	ADF Permitted Capacity	Current (2019-2020)	Near-Term (2030)	Long-Term (2045)	Buildout (2070)
Chlorine Contact Tanks	6.6	2.8	3.6	4.4	4.8
Recycled Water PS	6.6	1.8	-	-	-
Effluent PS	9.5	6	7	7.8	8.1
Percolation Ponds (TBD)	-	-	-	-	-
DAF Thickeners	9.5	-	7	7.8	8.1
Digesters	9.2	-	7	7.8	8.1
Centrate Management (TBD)	-	-	-	-	-
Centrifuges (TBD)	-	-	-	-	-
Digester Gas Facilities (TBD)	-	-	-	-	-

5.4 72-Hour Power Outage Evaluation

This section describes a 72-hr power outage evaluation, indicates the potential deficiencies in WWTP structure, and provides operational strategies to mitigate plant failure in case of an outage.

5.4.1 Existing Backup Power Generators

The City has an existing 1,250 kW diesel-powered backup generator on standby to meet WWTP power demand during a power outage. According to the 2020 Comprehensive Condition Assessment Report, the existing standby generator was installed in 2015. Based on the information provided by the City, the standby generator can supply 100% of the plant’s electrical services at 100% load in case of an emergency or power outage. Historically, the longest continuous usage of the backup generator has been no longer than 8 hours. During the longest event, centrifuges were not in operation, so electrical load was not at 100%.

5.4.2 Existing Protocols

Currently there is a written Standard Operating Procedure (SOP) for plant describing how to operate and maintain the facility in emergency working conditions during a 72-hr power outage. The existing SOP can be found in **Appendix B**.

5.4.3 Existing Operational Challenges

Based on the City’s operations experience, the list of anticipated key operational challenges and issues in the event of a 72-hr power outage is described below:

- Possible wasting to beds due to the load on the generator being unable to support centrifuge operation
- Maintaining blower operations for MBR & Conventional process
- Maintaining process control
- Telemetry problems
- Valve functioning
- Running SCADA

- Drainage of UPS batteries for power to computers, PLC, SCADA, & HMI
- Maintaining generator & fuel supply
- Maintaining sodium hypochlorite disinfection dosage
- Lighting at night
- Maintaining adequate temperatures for digesters during winter season

5.4.4 Mitigation Strategies

- Install CHP/cogeneration system to provide onsite, back-up generated electricity in order to support facility needs during a power outage and also offset energy costs during normal operations.
- Install solar panels with battery storage to provide sustainable power source to support energy needs during a power outage and offset energy costs during peak demand time operations.
- Utilize waste heat from CHP for process heat (i.e. hot water, steam, and other types of process heat) to supplement temperature for digesters. This could potentially decrease system operation time and increase digester efficiency, as well as save energy.

5.5 Potential Sites for Future WWTP Expansion

This section details potential sites which may be used for any future WWTP expansion, which is either detailed in this report or may be suggested in the future. These sites are identified by letters (A-F) in **Figure 5.4**. This includes areas for MBR expansion, EQ basin expansion, a contractor staging zone, onsite recycled water storage, and a cogeneration system.

Figure 5.4: Potential Areas of Expansion

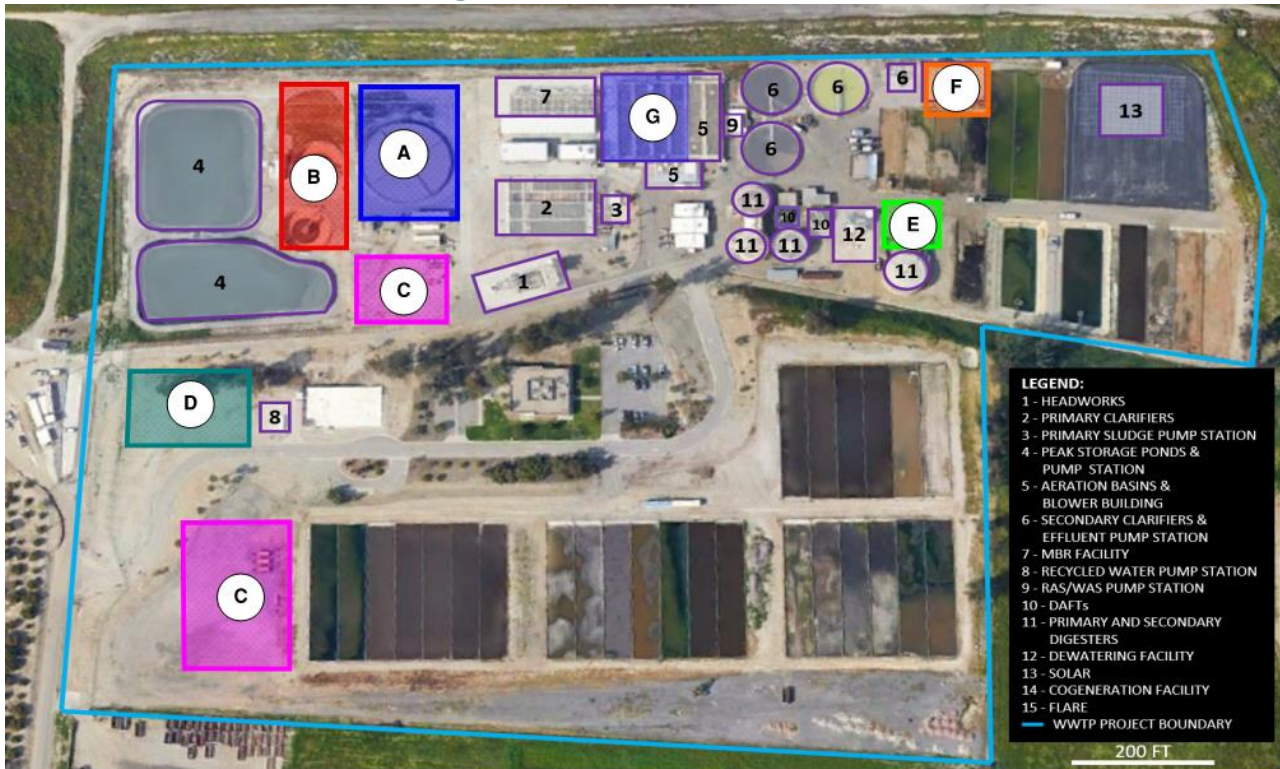

POTENTIAL FUTURE EXPANSION AREAS

- (A) AREA FOR MBR EXPANSION AND FINE SCREENS
- (B) USE CLARIFIER AREA FOR FUTURE EQ BASIN EXPANSION
- (C) USE FOR POTENTIAL CONTRACTOR STAGING AREA
- (D) USE DESIGNATED AREA FOR FUTURE RECYCLE WATER STORAGE
- (E) USE DESIGNATED AREA FOR NEW SLUDGE HANDLING EQUIPMENT
- (F) USE DESIGNATED AREA FOR NEW COGENERATION EQUIPMENT
- (G) USE ACTIVATED SLUDGE BASINS FOR FUTURE MBR EXPANSION

5.6 Cogeneration Cost-Benefit Analysis

The purpose of this section is to evaluate the potential of using WWTP-generated biogas for onsite power generation utilizing a pre-packaged, containerized CHP/cogeneration system. A 20-year life-cycle cost analysis on the use of landfill and digester-produced gas for cogeneration is presented. A comparison is made between baseline and cogeneration operating costs under a normal (90% operational usage) and a worst-case (75% operational usage) scenario, although the focus is on the worst-case scenario. The life-cycle cost analysis finds that cogeneration is more cost-efficient under projected higher electricity rates even in the worst-case scenario.

5.6.1 Background on Cogeneration

Anaerobic digesters and landfills generate biogas, is a mixture of gasses including methane and carbon dioxide. The methane in biogas can be captured and used to produce electrical and thermal energy at a WWTP using a combined heat and power (CHP) system, providing a reliable and resilient source of power for WWTPs. CHP systems increase energy security by producing energy at the point of use and reduce overall plant energy costs from outside sources. Additionally, CHP systems function to reduce the carbon footprint of WWTP's by capturing the energy in GHG emissions and offset grid power generation emissions that provide grid energy. CHP systems consist of equipment such as gas treatment tanks, engine generators, heat recovery equipment, and electrical interconnections. Typical CHP systems are internal combustion engines, microturbines, gas turbines, or fuel cell

modules. The general characteristics of each type of CHP system are provided in **Table 5.7** and a typical process flow diagram block is provided in **Figure 5.5**.

Table 5.7: CHP Engine Types and Specifications

CHP Technology	Size	Electric Conversion Efficiency with Higher Heating Value	CO ₂ Emissions (lbs per MWh)
Internal Combustion	100 kW – 5 MW	28% – 29%	410 – 1,030
Microturbines	30 kW – 400 kW	23% – 26%	1,540 – 1,780
Gas Turbines	1 – 5.5 MW	21% – 28%	890 – 1,450
Fuel Cells	250 kW modules	36% – 42%	-

The technologies described in Table 5.7 convert biogas into electric power. The energy in the fuel that is not converted to electricity is released as waste heat, which may also be harnessed for use at the facility.

In addition to methane and carbon dioxide, digester biogas contains hydrogen sulfide (H₂S), siloxanes, nitrogen, hydrogen, and water vapor that can significantly decrease the performance of CHPs. High H₂S concentrations can cause equipment corrosion and increased maintenance costs. Therefore, prior to feeding biogas to CHP systems, gas pre-treatment is required. The gas pre-treatment involves integrated control systems which typically consist of a gas cleanup skid, compressor, cooling, heat exchanger, and flare in order to properly control and maintain the performance of CHP systems. The design of gas cleaning systems can vary and therefore, this aspect needs to be considered during the design process. Refer to **Appendix C** for the most common techniques available for gas-pretreatment. Most gas treatment units are skid mounted and can be installed outdoor or under a shelter.

Figure 5.5: Typical Process Flow Diagram for Cogeneration

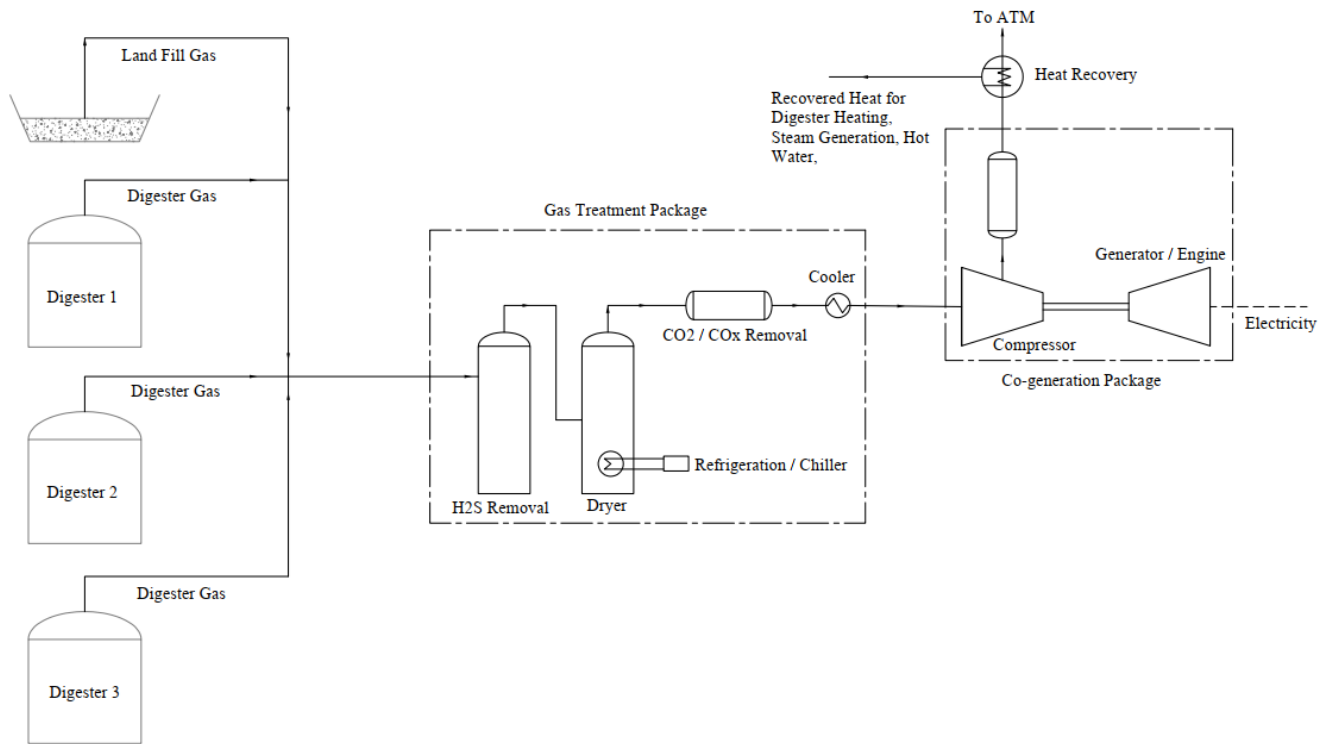

5.6.2 Opportunity for Cogeneration at Redlands WWTP

Historically, there was one 1-MW rated cogenerator at the WWTP which was installed in 2003 and remained in operation until 2009. In 2009, the cogenerator stopped operating due to exceeding AQMD emission standards. According to the Task 1 Comprehensive Condition Assessment Final Report, the existing cogeneration equipment is currently inoperable. Presently the plant does not utilize any energy recovery through cogeneration and biogas from the onsite landfill and anaerobic digesters is flared off. Current heat exchangers are fueled by digester gas. Natural gas is used in absence of digester gas or as a supplemental fuel source.

The quantity of biogas being produced presents an opportunity for a CHP system which would provide onsite generated electricity and thermal energy to the plant. Therefore, Dudek performed an evaluation and life-cycle analysis of a standalone, containerized, packaged cogeneration unit that converts biogas and landfill gas into electric heat and power. The new packaged unit consists of a gas conditioning/cleaning package, engine/generator, engine controls, radiators, Continuous Emissions Monitoring (CEMs) unit, Selective Catalytic Reduction (SCR)/oxidation catalyst, exhaust stack, and prechamber gas compressor. Refer to **Appendix D** for details. All relevant air quality emission levels e.g. NO_x concentrations, would be reduced to comply with SCAQMD accepted levels using the SCR system and urea, and emissions monitored with a CEM device, as a CEM unit is currently required by the SCAQMD. A gas conditioning pre-treatment system would remove moisture, H₂S, siloxanes, and other critical organic compounds to improve efficiency.

5.6.3 Life-Cycle Cost Analysis Model

A 20-year life-cycle cost model was prepared for two scenarios 1) 75% operational usage of cogeneration system (conservative scenario), and 2) 90% operational usage of cogeneration system (expected scenario). Equipment suppliers verified these scenario assumptions as reasonable. Both scenarios are compared with the existing conditions of having no cogeneration system in place. The life-cycle cost model parameters are shown in **Table 5.8**. Capital costs (e.g. construction costs) and O&M costs are estimated based on vendor equipment quotations and third-party vendor service and installation fees. Unit O&M costs are escalated by an annual inflation rate of 3% (Table 5.8). Capital cost estimate is shown in **Table 5.10**. O&M includes savings on electrical costs from onsite power generation. The present worth values of the annual loan payments and annual O&M costs are discounted at a rate of 6% (Table 5.8). The life cycle cost analysis compares scenarios based on their present worth value. O&M includes savings on electrical costs from onsite power generation.

Table 5.8: Lifecycle Cost Model Inputs

Parameter	Units	Value
Starting Year	-	2021
Ending Year	-	2041
Loan Duration	yr	20
Loan Interest Rate	%/yr	3
Discount Rate	%/yr	6
Inflation Rate	%/yr	3
O&M Escalation Rate ¹	%/yr	1
Electricity Cost, Year 2021 ²	\$/kWh	0.13

Notes:
¹ Escalation rate provided by the third-party
² Electricity cost obtained based on 2020-2021 electricity bills data provided by the City.

5.6.3.1 Baseline Conditions

The WWTP doesn't currently utilize cogeneration. Biogas coming from two-stage digestion process and landfill is flared off. Based on the Monitoring and Summary process evaluation data from March 2020 – February 2021, approximately 219,000,000 cu.ft/year of biogas is flared off. For the purposes of this evaluation, there is no capital cost associated with maintaining the existing system. Additionally, since labor and maintenance costs for operating the current system are unknown, only electrical costs are considered. Refer to **Table 5.9** to see breakdown of estimated annual O&M cost for the existing WWTP.

Table 5.9: O&M Cost Estimate for Existing Conditions

O&M COST ITEM DESCRIPTION	ENGINEERING ESTIMATE	
	UNIT COST	TOTAL
Power, Year 2021	\$	901,435
Total Annual O&M Cost, Year 2021	\$	901,435
20-year Present Worth O&M Cost	\$	13,920,000

5.6.3.2 75% Operational Usage (Conservative Scenario)

In the conservative scenario, the cogeneration system is assumed to operate only 75% of the year. Other major assumptions include:

- General Requirements are estimated based on 5% of total construction cost.

- The prepacked cogeneration unit is containerized to eliminate additional costs for maintaining a building
- The engine is prepackaged/containerized to reduce capital costs, complexity, and risk while having one company as a single point of responsibility for commissioning, maintenance, and long-term service.
- Electrical capital costs are estimated to be 5% of total construction cost.

Table 5.10 and Table 5.11 summarize estimated 75% operating cogeneration scenario capital and year 2021 O&M costs, respectively. Capital costs were developed using a third-party budgetary cost estimate.

Table 5.10: Capital Cost Estimates

CAPITAL COST ITEM DESCRIPTION	ENGINEERING ESTIMATE	
	TOTAL	
	\$/Unit	Net Cost \$
Division 1 - General Requirements		\$ 300,000
General Requirements (5% of overall construction cost)	\$ 300,000	\$ 300,000
Division 11 - Equipment		\$ 4,030,300
Pre-packaged Cogeneration Unit (1,000 kW)	\$ 4,030,300	\$ 4,030,300
Division 15 - Mechanical		\$ 90,000
Stainless Steel Pipes (8")	\$ 120	\$ 60,000
Valves	\$ 30,000	\$ 30,000
Division 16 - Electrical		\$ 460,000
Electrical (5% of overall construction cost)	\$ 300,000	\$ 300,000
Control Panel	\$ 160,000	\$ 160,000
Division 17 - Instrumentation		\$ 75,000
Sensors and Alarms	\$ 75,000	\$ 75,000
	Construction Subtotal	\$ 4,960,000
	Construction Contingency (20%)	\$ 992,000
	Construction Total	\$ 5,950,000

Annual O&M costs were developed for each alternative using a third-party budgetary Gold Long-Term Service Agreement (LTSA) services as a baseline. Major assumptions include:

- Cogeneration system is in operation for 75% of the year.
- Operational fee is \$28/OPH/Engine.
- Single point of responsibility for maintenance.
- Standard services include oil changes, coolant changes, vibration analysis, annual alignment, emission testing verification, engine batteries, minor overhaul, generator reconditioning at overhaul.
- Standard fluids/consumables, and basic analysis kits e.g. engine lubricant oil sample kits are included.

Table 5.11: O&M Cost Estimate for 75% operation

O&M COST ITEM DESCRIPTION	ENGINEERING ESTIMATE	
	UNIT COST	TOTAL
Excess Power Purchased, Year 2021	\$/kWh/yr	\$ 229,179
O&M, Year 2021	\$/yr	\$ 224,240
Total Annual O&M Cost, Year 2021		\$ 453,419
20-year Present Worth O&M Cost		\$ 7,000,000

5.6.3.3 90% Operational Usage (Normal Scenario)

The estimated capital costs for the normal scenario are the same as the conservative scenario (\$5,950,000). However, the annual O&M costs are lower as the cogeneration system operates 90% annually and additional onsite electricity is generated, making the system more cost-effective. All other major assumptions for the O&M in the 90% are the same.

Table 5.12 lists O&M for 90% of operation (normal scenario)

Table 5.12: O&M Cost Estimate for 90% operation

O&M COST ITEM DESCRIPTION	ENGINEERING ESTIMATE	
	UNIT COST	TOTAL
Excess Power Purchased, Year 2021	\$/kWh/yr	\$ 91,672
O&M, Year 2021	\$/yr	\$ 224,240
Total Annual O&M Cost, Year 2021		\$ 315,912
20-year Present Worth O&M Cost		\$ 4,900,000

5.6.4 Summary and Comparison

A payback period for the two alternatives was determined based on capital cost, annual O&M, and any annual energy cost savings compared to the existing treatment system. A summary of these costs and the payback periods is shown in Table 5.13. The most significant cost savings from the cogeneration scenarios comes from the decreased power usage.

Table 5.13: Comparison of major cost items between existing and proposed upgrades over 20 years

Item	Existing Conditions	Conservative Scenario	Normal Scenario
Total Capital Cost	\$0	\$5,950,000	\$5,950,000
Annual Power Usage (kWh)	7,051,660	7,051,660	7,051,660
Annual Power Generation (kWh)	\$0	5,288,700	6,346,500
Annual Cost of Energy to be Purchased (\$)	\$901,435	\$229,179	\$91,672
Annual Cost Reduction (%)	\$0	75%	90%
Annual O&M	\$901,435	\$453,419	\$315,912
Payback Period (years)	0	16	11
Life Cycle (20 years) Savings	\$0	\$965,000	\$3,088,000

In the conservative scenario, the CHP system is capable of generating 5,288,700 kWh, and only 1,762,900 kWh needs to be purchased from the grid. The payback period of the system is expected to be approximately 16 years. By comparison, in the normal scenario the CHP system is capable of generating 6,346,500 kWh, and only 705,200 kWh needs to be purchased from the grid. The total payback period is estimated to be approximately 11 years. Cogeneration can help reduce the current plant electricity costs from nearly \$1 million per year to less than \$100,000 per year.

Note that cost/benefit analysis for cogeneration is using conservative estimates and does not include the additional benefit of waste heat recovery. The City currently heats the anaerobic digesters with boilers. Typically, it is recommended to capture and utilize the waste heat from the generators to heat the digesters, which would lead to additional energy and O&M savings by reducing boiler run times by 75%-90%.

5.7 WWTP Process Evaluation Conclusions and Recommendations

The following conclusions and recommendations are based on the above analysis of process treatment capacity and cogeneration system evaluation. Key takeaways include:

- WWTP unit processes have sufficient capacity to maintain performance and reliability of the plant in the near, mid, and long term. Plant expansion to accommodate additional flows is not anticipated.
- Conservative assessment of the cost/benefit for a cogeneration system suggests that payback would range from 11 to 16 years. This does not include the additional benefit of waste heat recovery to heat the anaerobic digesters, which would reduce the payback period. The project team believes that if a detailed preliminary design is completed a shorter payback period may be achievable when costs are refined. In addition, increases in energy costs over time have not been considered and would also reduce the payback of the facility beyond what is calculated. A cogeneration system with an expected useful life of 20 years would save the City between \$1 million to \$3 million after 20 years, not accounting for savings related to waste heat recovery, if that is utilized.
- The capacity and performance of solids treatment facilities (i.e. digesters, thickening, and dewatering) should be further evaluated. Additional solids handling capacity may be required in the future if the City elects to receive food waste, FOG, and/or if solids loads to the plant increase.

- There is room in the WWTP's footprint for expansion. However, area to expand solids handling and gas handling facilities are tight. Sludge drying beds and/or clarifiers (assuming the conventional activated sludge train is abandoned and MBR is expanded) may be removed to allow for space for future facilities.
- An optimized and engineered cogeneration system would reduce the air pollution and carbon monoxide emissions compared to the status quo of direct flaring of digester gas. Meanwhile, cogeneration would provide a source for heating requirements within the plant.
- The cogeneration system and SCR unit would have environmental benefits, namely greenhouse gas emissions and carbon footprint reduction compared to purchase of grid energy and gas flaring. Utilizing a sustainable source of biogas would contribute towards California's Carbon Zero 2045 initiative. The SCR unit would also reduce other air quality emissions to acceptable SCAQMD regulatory limits.
- The City of Redlands' Climate Action Plan identifies a goal of 10% reduction in GHG emissions from water utilities by 2035. Utilizing the renewable biogas on site for generation would offset net GHG emissions and contribute to meeting both the City and State's climate action goals.
-

6 Recommendations

This section incorporates the findings of previous sections and outlines the estimated costs of the recommended collection system and WWTP improvements. The identified improvements are subsequently prioritized into a recommended list of capital improvement program projects based on pipeline capacity and the WWTP process evaluation.

6.1 Pipeline Capacity Project Recommendations

In Chapter 4, a total of 10 pipeline improvements were identified. Each improvement project was assigned a project ID as presented in **Table 6.1** and shown graphically in **Figure 6.1**. Due to the capacity analysis being based on a hydraulic model calibrated on only the WWTP influent flow meter, it is recommended that system-wide flow monitoring be performed prior to commencing each improvement. The system-wide flow monitoring should ensure a flow meter at each of the recommended pipeline improvement locations noted below.

Please note that while some areas recommended for upsizing in the 1998 SMP were also found in this updated analysis, several were not identified as part of this master plan. This could be due to two factors. First, water conservation efforts within the last twenty years have led to a decrease in sewer flows and therefore less capacity deficiencies. Second, the 1998 analysis did use collection system flow monitoring, which allows for more accurate evaluation of flow volumes in any individual pipe compared to using solely the WWTP influent flow meter measurements allocated by water usage, as done for this study. This is also why it is recommended the City perform flow monitoring prior to commencing the following recommended improvements.

Table 6.1: Recommended Pipeline Capacity Projects

Project ID	Phasing	Project Description ¹
P-0	2021-2030	System-wide Flow Monitoring Program (up to 30 meters)
P-1	2021-2030	Install 1,350 LF of 12-inch pipe on Cajon St, from Cypress Ave to Fern Ave
P-2	2021-2030	Install 100 LF of 15-inch pipe on Cajon St, directly south of E Citrus Ave
P-3	2021-2030	Install 920 LF of 24-inch pipe on San Bernardino Ave and 2,700 LF of 36" inch pipe on Alabama St
P-4	2021-2030	Install 700 LF of 10-inch pipe on Brockton Ave at 6 th St & Herald St
P-5	2021-2030	Install 350 LF of 27-inch pipe on Citrus Plaza Dr, just south of San Bernardino Ave
P-6	2021-2030	Install 1,900 LF of 30-inch pipe on Nevada St, beginning north of Palmetto Ave
P-7 ²	2030-2045	Install 300 LF of 10-inch pipe on South Ave, between Garden St and Franklin Ave
P-8	2030-2045	Install 2,100 LF of 12-inch pipe on Cajon St, between 600 feet north of Highland Ave and Cypress Ave
P-9 ²	2045-2070	Install 300 LF of 10-inch pipe on South Ave at Franklin Ave
P-10	2045-2070	Install 300 LF of 15-inch pipe on Cajon St, just north of Vine St

Note:

¹ It is recommended all capacity restricted areas be flow monitored to confirm capacity restrictions exist.

² These two projects could be combined into one.

Figure 6.2: Results of Cajon St (Between Cypress Ave and Fern Ave) Capacity Improvement Under Existing (2020) Conditions, Sized for Buildout (2070) Conditions

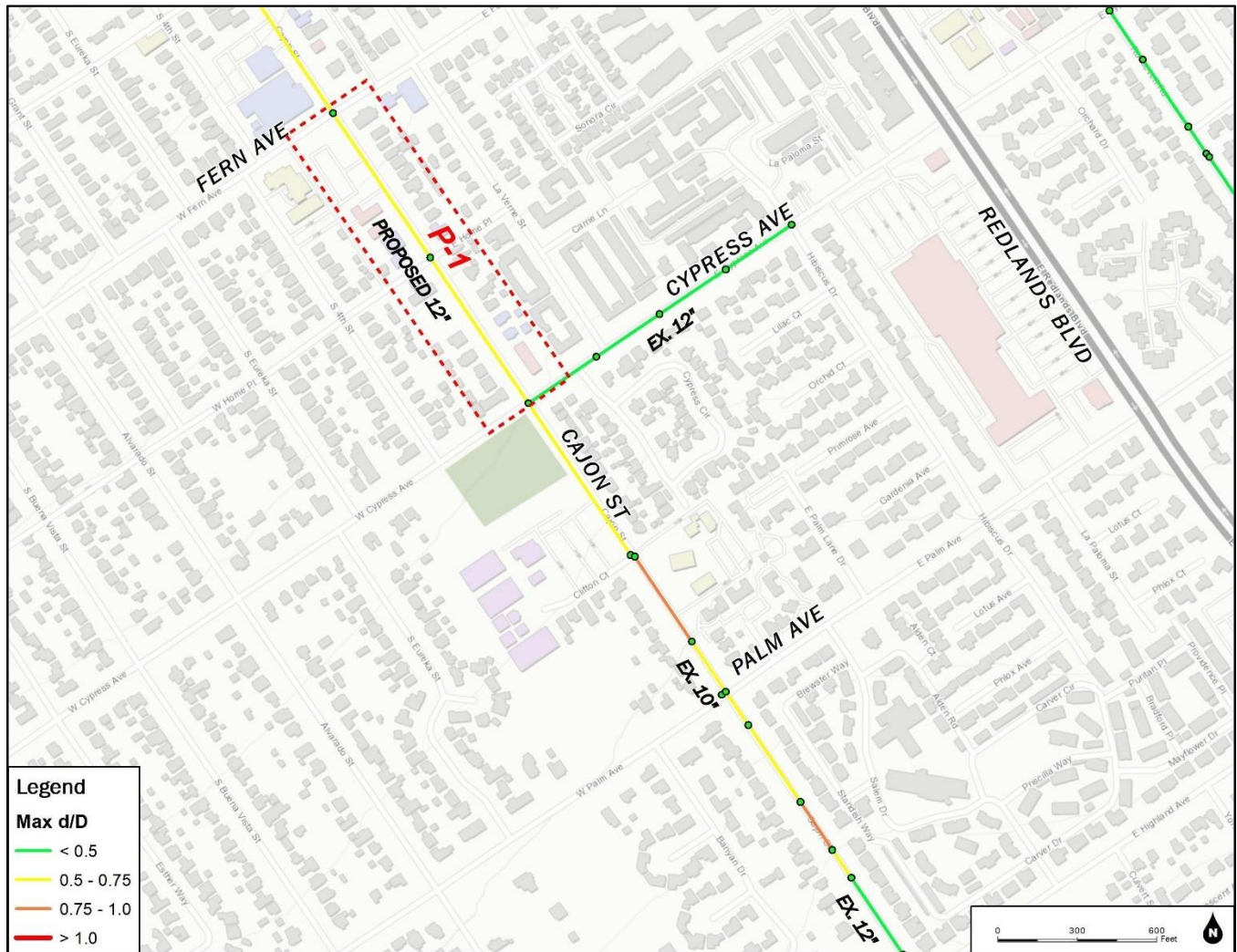

Figure 6.4: Results of Alley East of Alabama St (Between San Bernardino Ave and Palmetto Ave) Capacity Improvement Under Existing (2020) Conditions, Sized for Buildout (2070) Conditions

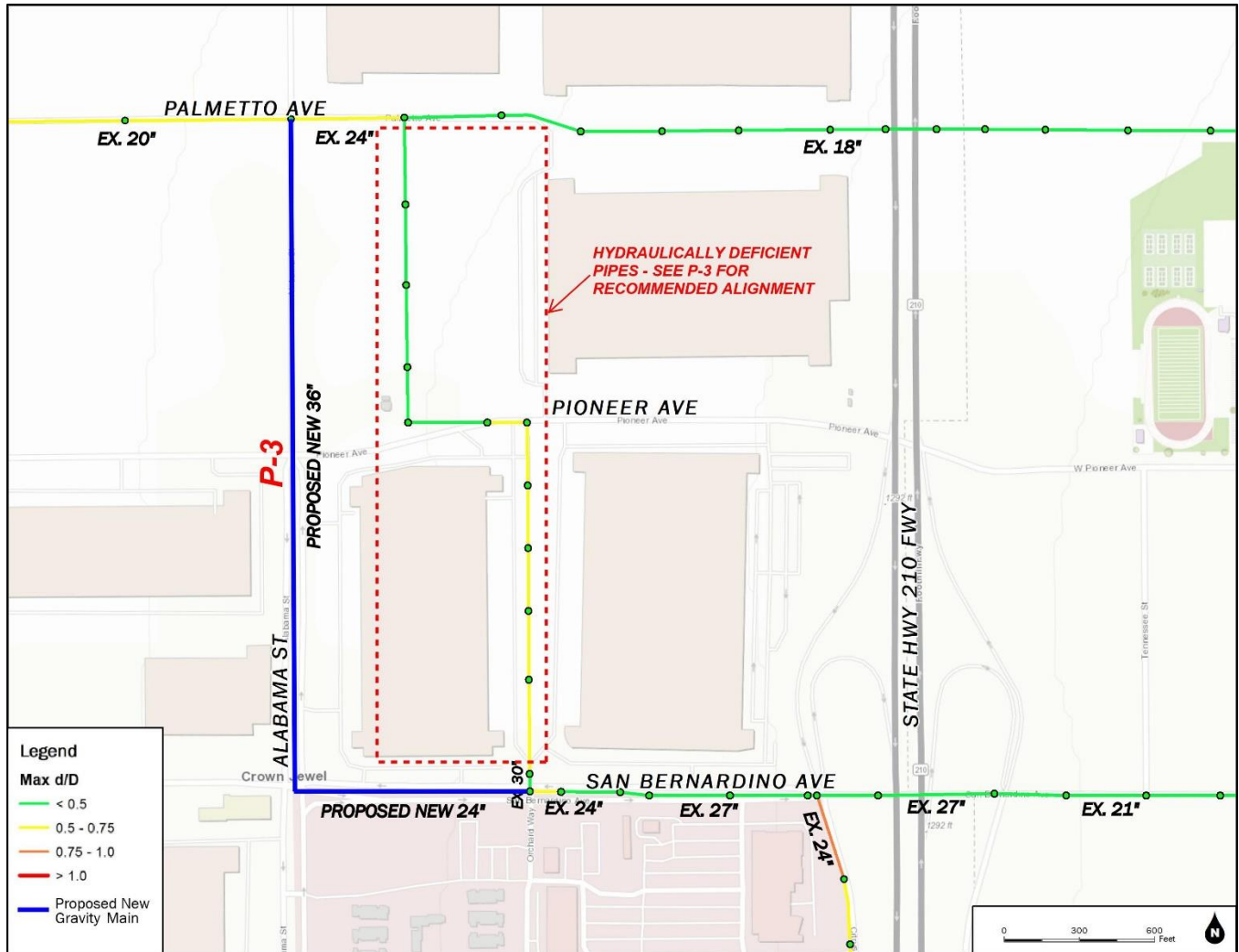

Figure 6.5: Results of Brockton Ave at 6th St & Herald St Capacity Improvement Under Near-Term (2030 Conditions), Sized for Buildout (2070) Conditions

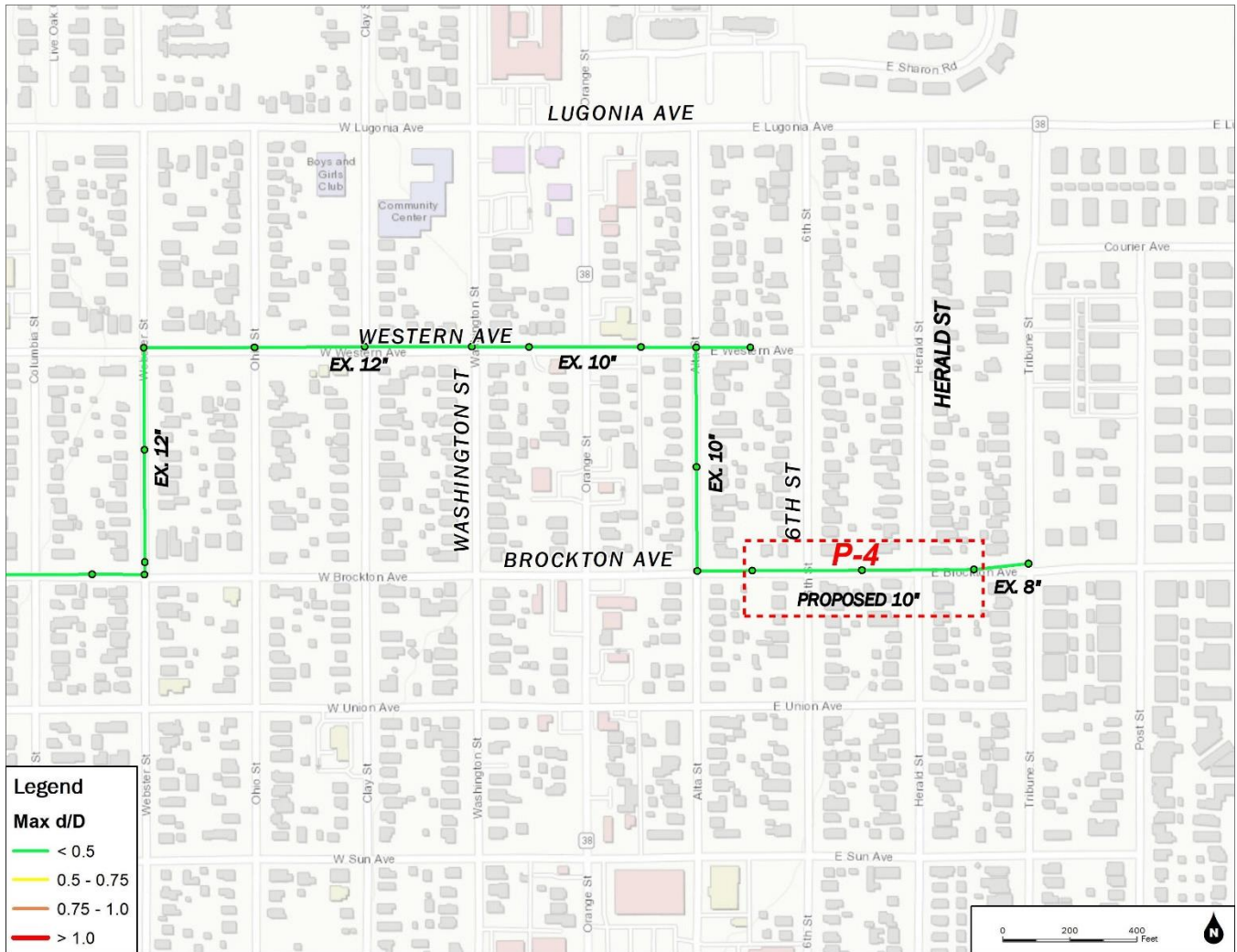

Figure 6.6: Results of Citrus Plaza Dr (South of San Bernardino Ave) Capacity Improvement Under Near-Term (2030 Conditions), Sized for Buildout (2070 Conditions)

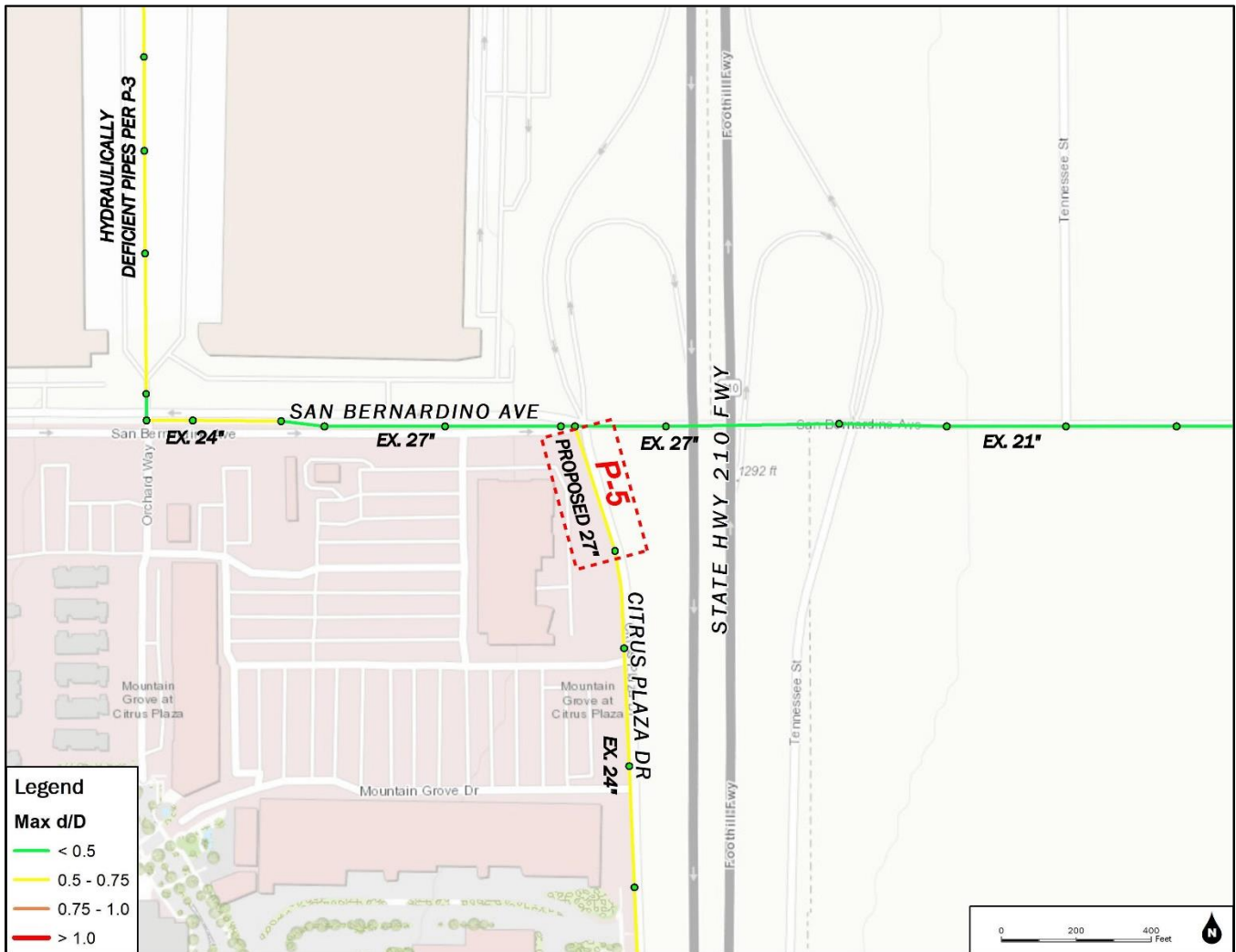

Figure 6.7: Results of Nevada St (North of Palmetto Ave) Capacity Improvement Under Near-Term (2030 Conditions), Sized for Buildout (2070) Conditions

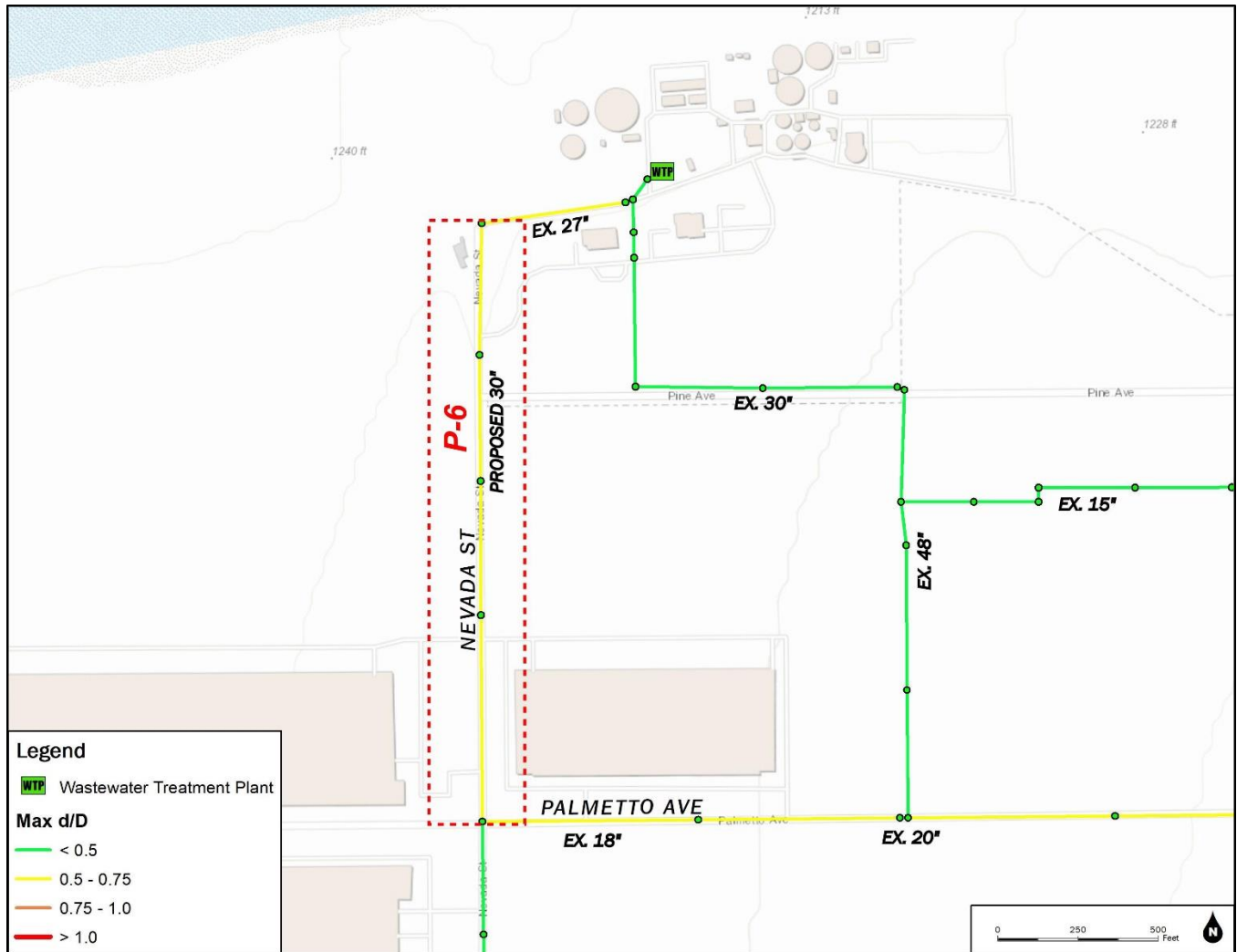

Figure 6.8: Results of South Ave (Between Garden St and Franklin Ave) Capacity Improvement Under Long-Term (2045) Conditions, Sized for Buildout (2070) Conditions

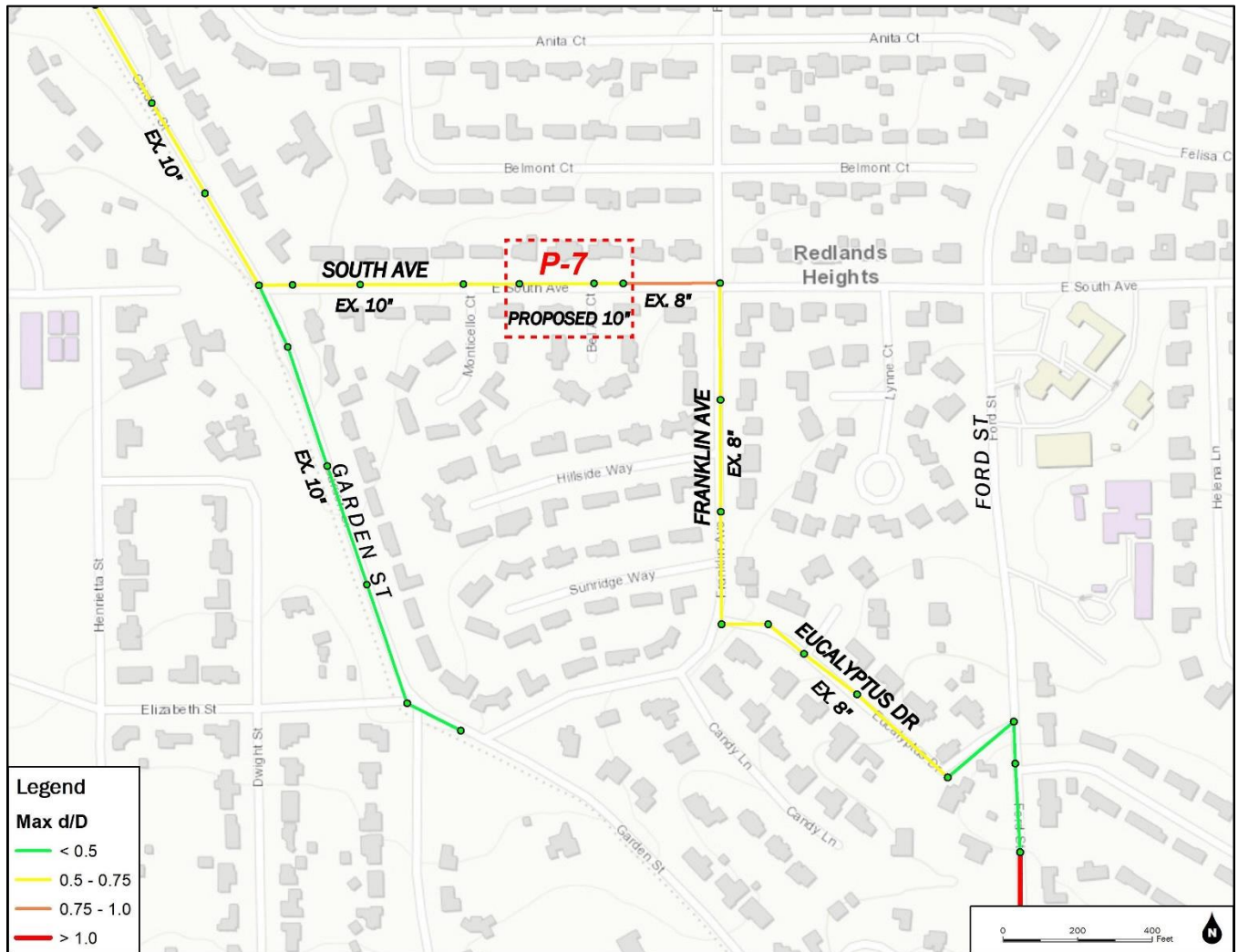

Figure 6.9: Results of Cajon St (Between 600 feet North of Highland Ave and Cypress Ave) Capacity Improvement Under Long-Term (2045) Conditions, Sized for Buildout (2070) Conditions

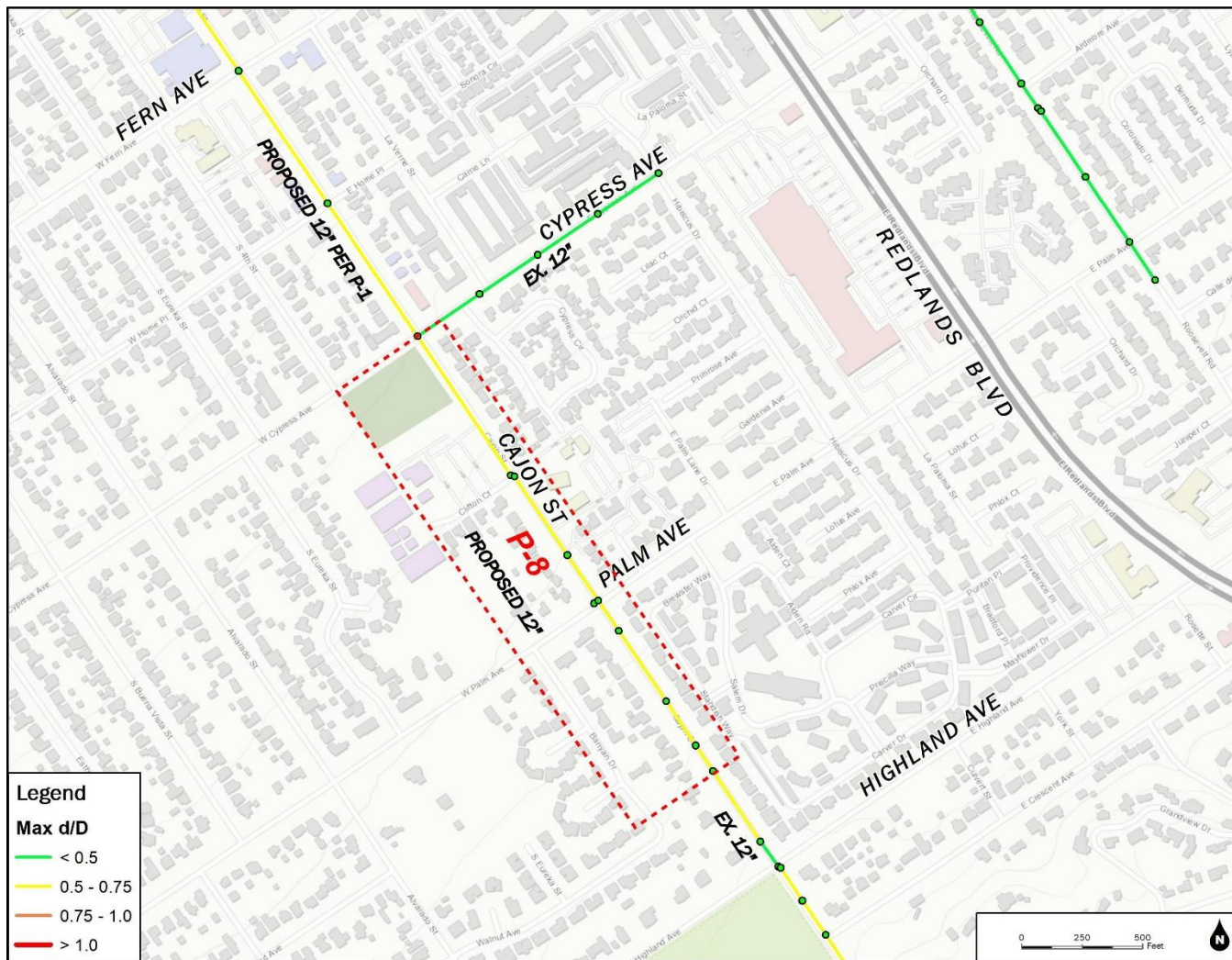

Figure 6.10: Results of South Ave Capacity Improvement Under Buildout (2070) Conditions

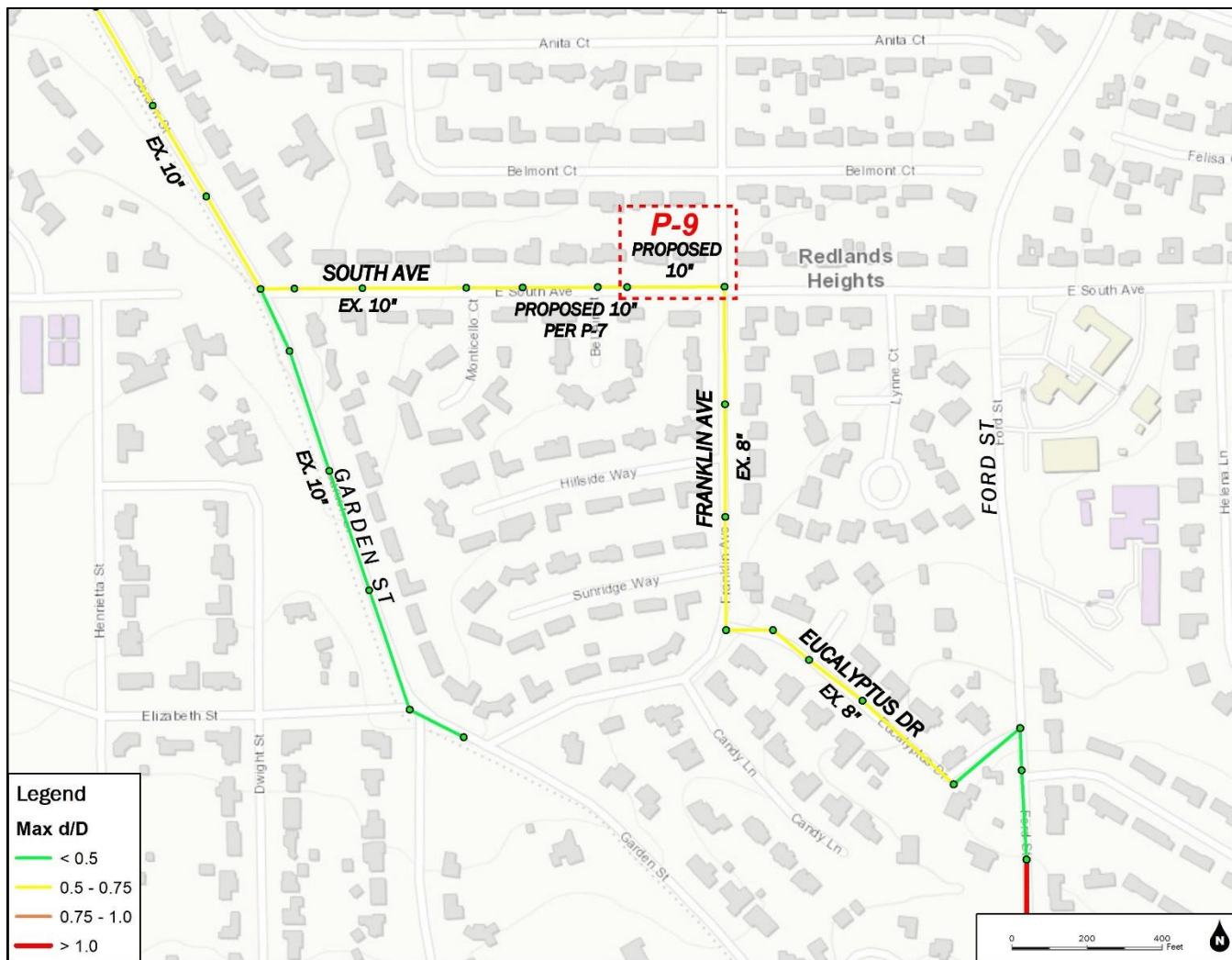
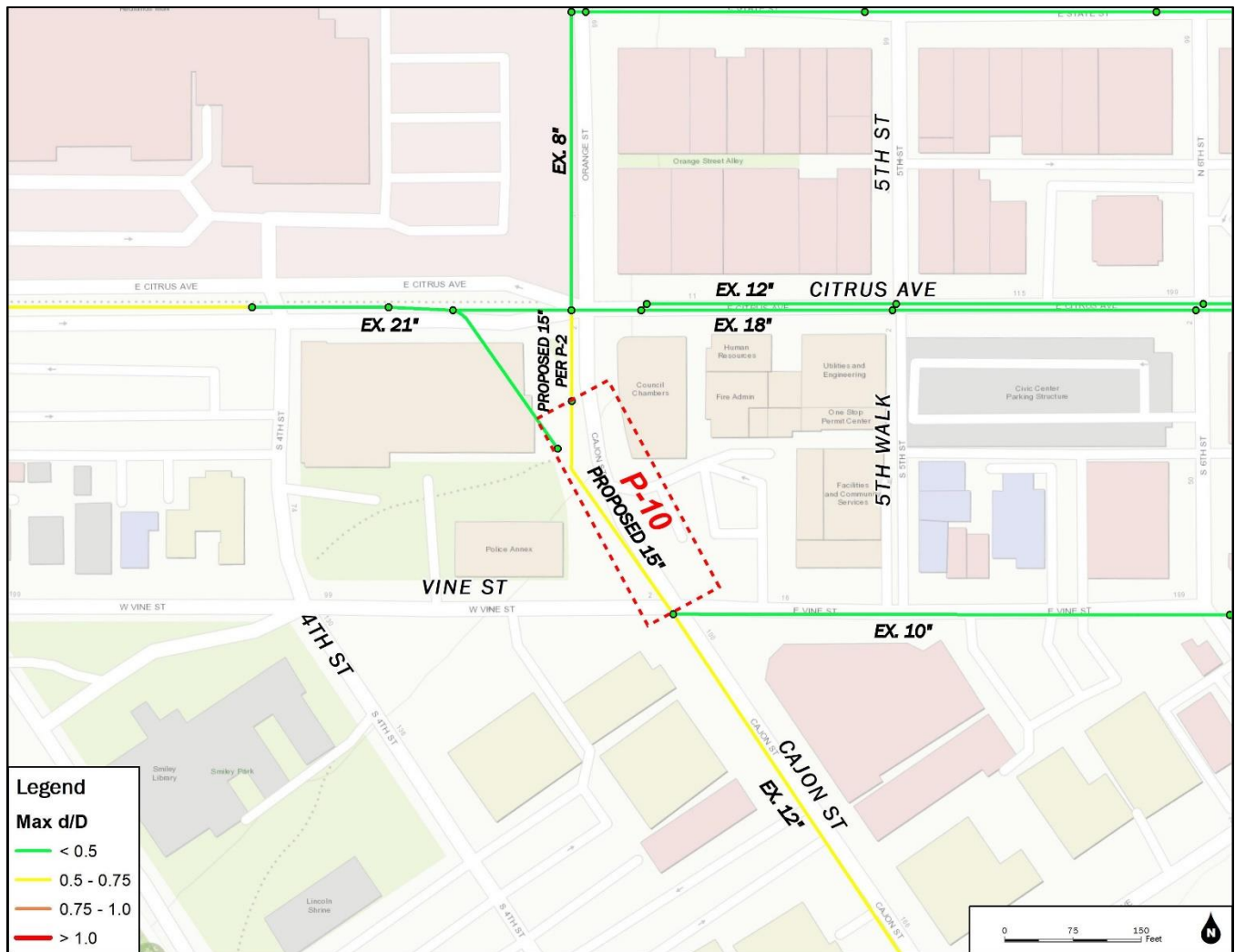

Figure 6.11: Results of Cajon St (North of Vine St) Capacity Improvement Under Buildout (2070) Conditions



6.2 Lift Station Operations Recommendations

It is recommended the City conduct an Optimization Study on the San Bernardino/Mountain View Lift Station to determine if there are opportunities to optimize operations. The existing pumps, sized to efficiently operate at 4 MGD, are operated at 2.5 MGD. Operating the existing pumps at 2.5 MGD is likely causing extra power usage through efficiency losses.

Table 6.2: Lift Station Recommendations

Project ID	Description
LS-1	Lift Station Optimization Study to improve power consumption

6.3 WWTP Process Recommendations

It is recommended that the City develops a solid treatment plan in the event the City elects to receive food waste, FOG, and/or if solids loads to the plant increase. For solids treatment, it is recommended to determine present solid loads and solid handling capacity at the plant. Additionally, it is recommended the City to consider replacing the existing, not-in-use cogeneration system with a new modern system, as this could reduce electricity usage rates by utilizing plant produced biogas. A new, optimized cogeneration system can also significantly reduce air pollution levels from the plant as biogas wouldn't be directly flared off to the atmosphere and would function as a reliable source for any heating process within the plant.

Table 6.3: WWTP Process Recommendations

Project ID	Description
WWTP-1	Solids Management Plan
WWTP-2	Cogeneration Facility Preliminary Design

6.4 Project Cost Summary

The following **Table 6.4** provides a summary of probable construction and project costs associated with each of the above recommended capital improvement projects. A detailed tabulation of each projects cost elements is included in **Appendix E**. Note that due to the varying lengths of the pipeline replacement projects, standard multipliers were not used. Cost ratios are typically higher for shorter replacement projects and reduce as the size of the replacement length increases. Instead, mathematical equations were used to calculate estimated pipeline replacement costs (\$/in-diam/LF) as well as the Engineering multipliers

Table 6.4: Project Cost Summary

Project ID	Project Name	Description	Justification	Project Costs by Planning Period (\$)			
				Existing (2020)	Near-Term (2030)	Long-Term (2045)	Buildout (2070)
Gravity Sewer Projects							
P-0	System-Wide Flow Monitoring	Install thirty (30) flow meters throughout existing sewer system	Confirm the need for each improvement based on real-time flow monitoring data	\$ 162,000	-	-	-
P-1	Cajon St, Cypress Ave to Fern Ave, Pipeline Upsizing	Upsize 1,350 LF of 10-inch to 12-inch	Max d/D is 1.0 under 2020 PWWF	\$ 827,000	-	-	-
P-2	Cajon St at Citrus Ave Pipeline Upsizing	Upsize 100 LF of 12-inch to 15-inch	Max d/D is 1.0 under 2020 PWWF	\$ 141,000	-	-	-
P-3	Alabama St Pipeline Upsizing and Realignment	Install concrete plug to abandon 3,100 LF of existing 24-inch and 30-inch; Build 920 LF of new 24-inch in San Bernardino Ave; Build 2,700 LF of 36-inch in Alabama St	Max d/D is 1.0 under 2020 PWWF	\$ 4,967,000	-	-	-
P-4	Brockton Ave Pipeline Upsizing	Upsize 700 LF of 8-inch to 10-inch	Max d/D is 1.0 under 2030 PWWF	-	\$ 445,000	-	-
P-5	Citrus Plaza Dr Pipeline Upsizing	Upsize 350 LF of 24-inch to 27-inch	Max d/D is 1.0 under 2030 PWWF	-	\$ 671,000	-	-
P-6	Nevada St Pipeline Upsizing	Upsize 1,900 LF of 27-inch to 30-inch	Max d/D is 1.0 under 2030 PWWF	-	\$ 2,452,000	-	-
P-7	South Ave West of Franklin Ave Pipeline Upsizing	Upsize 300 LF of 8-inch to 10-inch	Max d/D is 1.0 under 2045 PWWF	-	-	\$ 233,000	-
P-8	Cajon St between Highland Ave and Cypress Ave Pipeline Upsizing	Upsize 2,180 LF of 10-inch to 12-inch	Max d/D is 1.0 under 2045 PWWF	-	-	\$ 1,136,000	-
P-9	South Ave at Franklin Ave Pipeline Upsizing	Upsize 300 LF of 8-inch to 10-inch	Max d/D is 1.0 under Buildout PWWF	-	-	-	\$ 233,000
P-10	Cajon St at Vine St Pipeline Upsizing	Upsize 300 LF of 12-inch to 15-inch	Max d/D is 1.0 under Buildout PWWF	-	-	-	\$ 346,000
Total Gravity Sewer Projects:				\$ 6,097,000	\$ 3,568,000	\$ 1,369,000	\$ 579,000
Lift Station Projects							
LS-1	San Bernardino/Mountain View LS Optimization Study	Conduct study to evaluation optimization of the MVLS	Pumps consistently operating at reduced speeds	\$ 40,000	-	-	-
Total Lift Station Projects:				\$ 40,000	\$ -	\$ -	\$ -
Wastewater Treatment Plant Projects							
WWTP-1	Solids Management Plan	Determine present solid loads and solids handling capacity at the plant.	Needed in the event the City elects to receive food waste, FOG and/or if solids loads to the plant increase.	\$ 150,000			
WWTP-2	Cogeneration Facility Preliminary Design	Preliminary design of new cogeneration facility for the WWTP.	Estimated 11 year payback period for construction of new Cogen facility.	\$ 300,000			
Total WWTP Projects:				\$ 450,000	0	0	0
TOTAL:				\$ 6,587,000	\$ 3,568,000	\$ 1,369,000	\$ 579,000

Appendix A

Near-Term Developments

APPENDIX A - NEAR TERM DEVELOPMENTS

Dev't Number	Development Name	Status	Location	Redevelopment	APN	Total Acreage of Dev't	Sq. Ft of Dev't Building	SFR (DU)	SFR (DU/acre)	Instit (acre)	Hotel (No. of rooms)	Comm (acre)	Indust (acre)	SFR (DU)	SFR (DU/acre)	MDR (DU)	MDR (DU/acre)	HDR (DU)	HDR (DU/acre)	Mixed Use (acre)	Instit (acre)	Hotel (No. of rooms)	Hotel (acre)	Comm (acre)	Indust (acre)
1	Tract 20378	Submitted	SE corner of Wabash Ave and Highland Ave	No	029-941-118, -119, -120, -121, -123, -124	9.8										120	12.2								
2	Canyon Ranch			No		22								27	1.23										
3	Tract 20320	In Process	Wabash Ave, north of Reservoir Rd and I10	No	017-428-113, -133, -134, -135 & 029-921-311 to-314, -321	65								67	1.03										
4	Citrus Valley SP (Tract 20336)	In Process	North side of Domestic Ave, west of Texas St and east side of I210 fwy	No	016-703-102 to -107, -116	58								317	5.47										
5	Casa Loma Apts (Tract 20126)	Planning Commission 12-16-2020	SW corner of University St and Lugonia Ave	No	121-237-101, -105 to -120											147									
6	Citrus Greens SP (Tract 20283)	In Process	NW Corner of Sunnyside Ave and Linda Vista Ave	No	017-223-107, -105	5								20	4.00										
7	Tract 20305	Historic Commission TBD	301 W. Palm Ave	No	017-323-105	8.8								30	3.41										
8	City Center Mixed Use Project (CUP No. 1138)	In Process	NW Corner of Brookside Ave and Eureka St	No	017-110-101 to -105, 017-121-113 to -121, 017-121-125	3														3					
9	The Grand Apartments	In Process	NE Corner of Redlands Blvd and Eureka St	Yes	016-928-130	1.5												149	99						
10	Tract 20257 (i.e. Heritage SP)	Approved	West side of Texas St, north side of San Bernardino Ave and south side of Pioneer Ave	No	016-709-102, -104, -105, -108	37								207	5.59										
11	LuxView Apts	Approved	North & South side of Orange Ave between Alabama St and Iowa St	No	029-216-708, -711, -712, -713, -718, -725, -803, -816	21.8										328	15.0								
12	Brookside Apts	Approved	317 Brookside Ave	No	017-124-124											8									
13	Liberty Lane Apts	Approved	SW corner Lugonia Ave & Texas St	No	016-902-119	4.72										80	16.9								
14	Tract 20065	Approved	South side of E. Highland Ave, west of Redlands St	No	017-416-125	10								29	2.90										
15	Tract 19956	Approved	East of Wabash Ave, north of Highland Ave, and south of Citrus Ave	No	029-942-101 to -142	18.5		40	2.16																
16	Tract 17080	Approved	West side of S. Wabash Ave, north of E. Sunset Dr and south of I10	No	030-001-209, -210	7								8	1.14										
17	Tract 17022	Approved	NE Corner of W. Pioneer Ave & Texas St	No	016-788-106 to -120	4.3								12	2.79										
18	Tract 16878	Approved	SW Corner of Wabash Ave & E. San Bernardino Ave	No	016-813-201 to -205	41								76	1.85										
19	Tract 16402	Approved	South side of Madeira Ave, approximately 1,750 ft east of Crafton Ave and 350 ft east of Whitewood Dr	No	029-821-109, -139	8.5								26	3.06										
20	Tract 20126	Under Construction	NE corner of Lugonia & Judson	No	016-891-101 to -154, 016-892-101 to -155	39		23	0.59					82	2.10										
21	Tract 19942	Under Construction	East of Wabash Ave, north of Sylvan Blvd	No	029-943-101 to -138	12		13	1.08					21	1.75										
22	Tract 20079	Completed	1485 E. San Bernardino Ave	No		6		14	2.33																
53	Autofit	Submitted	1625 W. Redlands Blvd	Yes		2.51	109,147					2.51													
23	Symbiosis LLC, Medical Transport	Planning Commission 12-16-2020	1801 Orange Tree Ln	Yes		0.34	15,000					0.34													
24	CUP No. 1145	In Process	600 North Place	No	017-301-139	1	12,585											0.0	28						
25	SP 26, Amendment No. 3	Approved	1500 Barton Rd	No		0.09	4,052																	0.09	
26	Redlands Christian School	Approved	125 & 141 Kansas St	Yes		1.91	83,000			1.91															
27	Commission Review & Approval No. 909	Approved	North side of W. Redlands Blvd, approximately 250 feet east of Nevada St	No		1.89	16,714																	1.89	
28	Marrriott Springhill Suites	Approved	Lugonia Ave, between Nevada & Alabama St	No		1.67	55,465															88	1.67		
29	Retail Center	Approved	SW Corner of Orange St & Shoppers Lane	No		0.35	15,200																	0.35	
30	Jack In the Box	Approved/Plan Check	1248 N. Wabash Ave	No		0.07	3,000																	0.07	
31	Redlands Food Hall - Mutual Orange Distributors (MOD) Packinghouse	Approved/Plan Check	330 N. Third St	Yes		0.77	33,676																	0.77	
32	Third Street Retail Building	Approved/Plan Check	31 W. Stuart Ave	No		0.85	36,825																	0.85	
33	Downtown Parking Structure	Under Construction	South side of W. Stuart Ave at Third St	No		3.27	142,460																	3.27	
34	Self-Serve Carwash	Under Construction	SW Corner of Alabama St and Orange Tree Lane	No		1	7,967																	1.00	
35	Commission Review & Approval No. 908	Under Construction	North side of W. Colton Ave, 300 ft east of New York St	No		3.41	62,458																	3.41	
36	Hilton Home2 Suites	Under Construction	1342 Industrial Park Ave (adjacent to I10 off-ramp and west of Tennessee St)	No		1.67	44,540															77	1.67		
37	Packing House District, Phase 2	Under Construction	SW Corner of Stuart Ave & Eureka St	No		3.9	15,250																	3.90	
38	CUP No. 1130	Under Construction	349 N. Eureka St	Yes		0.11	4,730					0.11													
39	CUP No. 1132	Completed	440 Oriental Ave	Yes		0.20	8,520					0.20													
40	Lugonia Station Post Office	Completed	1615 W. Park Ave	Yes		0.55	24,000																	0.55	
41	CUP NO. 1129	Completed	SE Corner of Stuart Ave & Eureka St	No		0.06	2,400																	0.06	
42	Woodspring Suites Hotel	Completed	1700 Orange Tree Ln	No		2.7	48,224				123	2.7													
43	Commission Review & Approval No. 923	In Process	10756 Nevada St	No		1.96	85,430																		1.96
44	Parking Lot Expansion (CUP No. 158)	In Process	SW Corner of Terracina Blvd & Fern Ave	Yes	017-214-107, -108, -111, -115, -116, -119	2.78								-2.78	-1.00										
54	Planned Development No. 4	In Process	NE Corner of Mountain View Ave and I10	No		22	420,000																		22
45	Commission Review & Approval No. 912	In Process	10843 New Jersey St	No		9	179,400																		9
46	Phelps Office Building	City Council 12-15-2020	1702 W. Park Ave	Yes		0.17	7,198																		0.17
47	CUP No. 1136	In Process	NW Corner of E. Lugonia Ave & Dearborn St	No		19.5	161,804														19.5				
48	Commission Review & Approval No. 900	Under Construction	NW Corner of Park Ave & Alabama St	No	029-215-410, -417	3.54	154,000						3.54												
49	ESRI Office Building	Under Construction	South side of Park Ave, between New York St and Tennessee St, adjacent to the existing ESRI campus	No		8.8	110,479																	8.8	
50	Commission Review & Approval No. 891	Completed	614, 624, 634 Nevada St	No		1.3	18,296						1.3												
51	Commission Review & Approval No. 894	Completed	SE Corner Park Ave & Iowa St	No		3.54	154,000																		3.54
52	Preliminary Review No. 1421	Completed	404 New York St	Yes		2.41	105,000					2.41													
55	Transit Villages SP (NewYork/ESRI Station)	Draft complete; EIR being prepared		No		19.2												0.0	489					2.31	
	Transit Villages SP (Downtown Station)			No		30.3													0.0	916			90		2.4
	Transit Villages SP (University Station)			No		26.1													0.0	595		1.29	129		5.69

Appendix B

2021 SOP Plant Power Outage



CITY OF REDLANDS

PLANT POWER OUTAGE

STANDARD OPERATING PROCEDURE

Joseph Hamburger
Wastewater Plant Supervisor

June 2021

Table of Contents

<u>Section</u>	<u>Page</u>
1. Introduction	3
2. Individual Roles and Responsibilities	3
3. Resource Requirements	4
4. Safe Practices and Procedures	4
5. Record Keeping	4
6. Procedure	5

Introduction

This Standard Operating Procedure (SOP) is to assist Operations and or Maintenance staff for a plant power outage. This is a guideline to help restore the wastewater plant back to normal operations and to minimize the possibility of a sewer overflow.

This Standard Operating Procedure (SOP) is designed to provide clear directive by identifying the following:

- Roles and Responsibilities
- Resource Requirements
- Safe Practices and Procedures
- Procedure, Maintain Plant

Roles and Responsibilities

The goal for defining the roles and responsibilities is to ensure that restoring the wastewater plant is conducted in a manner constant with plant safety and City policies and procedures. The major roles and responsibilities of staff can be best described as:

Wastewater Operations Superintendent

- Provide the leadership necessary to ensure the activities listed in the SOP are executed properly and safely.

Wastewater Operations Supervisor

- Assign, supervise, and review the activities listed in the SOP that are performed by Operations Staff.

Wastewater Operations Staff

- Come in to restart wastewater plant equipment.
- Maintain flow and process.
- Oversee safety practices and assist maintenance staff.
- Assist contractors as need, if needed.

Maintenance Supervisor

- Assign, supervise, and review the activities listed in the SOP performed by Maintenance Staff.
- Have maintenance staff restore any equipment failures
- Maintain standby generator.

Maintenance Staff

- Maintain standby generator and supply fuel when needed.
- Restore all failed equipment.

Collection Supervisor

- Assign collection staff to assist with Vactor truck, sewer overflows if needed.

Collection Staff

- Stop and clean-up all sewer overflows.

Contractor, TESCO, SUEZ, & Southern California Edison (SCE) Power Plant

- Restore all failed equipment that city staff could not put online.
- Restore SCADA issues.
- Restore MBR.
- Abide by City safety policies.
- Operations will notify SCE Power Plant at 800-655-4555

Resource Requirements

Personnel

- Wastewater Operations Superintendent
- Wastewater Operations Supervisor
- Wastewater Operations Staff
- Maintenance Supervisor or Foreman
- Collections Supervisor
- Maintenance Staff
- Collections Staff

Equipment Requirement

- Fuel for Generator

Personal Safety Equipment Requirements

- Safety glasses
- Gloves rubber or Latex
- Safety shoes

Safe Practices and Procedures

It is the responsibility of every employee to ensure that all applicable safety rules and regulations are adhered to during the performance of their duties. Specific safety policies and guidelines are located in the City of Redlands Injury and Illness Protection Policy.

Staff shall use appropriate Personal Protective Equipment (PPE) to protect themselves from hazards that may be encountered. If at any time a hazard is identified requiring additional PPE staff is to notify their supervisor prior to performing the task. Additionally the supervisors are to perform periodic inspections to ensure that activities are being performed in a safe manner, consistent with the applicable policies and regulations.

The minimum items of personal protective equipment are:

- Gloves rubber or Latex
- Safety shoes
- Safety glasses

Contractor will follow city's and company safety procedures.

Record Keeping

In order to document the activities performed in the SOP, it is essential that accurate records be maintained. It is imperative that the Daily logbook of activities is complete and entered correctly. All required records must be completed in a timely manner.

Power Outage Procedure

1. In the event of loss of power at the wastewater treatment plant, the Kohler emergency generator is electronically configured to automatically start and supply standby power to the plant whenever the MPAC 1500 Controller senses a loss of power exceeding 30 seconds. After this delay the Kohler standby generator is sent a run signal and starts automatically to supply emergency power to the wastewater treatment plant. Plant equipment is able to be operated once the standby power is available, however, an operator must physically reset and start plant equipment. The operator is notified of the loss of power by the plant's auto dialer.
2. The Supervisory Controlled Data Acquisition (SCADA) system initiates a call from the plant's auto dialer to the "on call" wastewater treatment plant operator. The "on call" operator acknowledges the alarm by pressing the number 9 on the "on call" cell phone. In the event that the operator should fail to acknowledge the alarm after two repeated calls, the auto dialer will call the operations supervisor one time and there after call the "on call" operator again twice.
3. The operator is to immediately respond to the call out, which should not exceed 30 minutes, and take the following steps:
 - a. The "on call" operator will notify a second operator to come in and assist with restoring plant equipment as soon as they get the call from the auto dialer that it is a loss of power alarm.
 - b. The operator will remotely log in and observe the alarms displayed on SCADA and take the appropriate steps to reset plant equipment. The critical equipment will be the Raw Sewage Pumps, Peak Storage Pond Pumps, Conventional Effluent Pumps, Aeration Blowers, Zenon Air Compressors, Zenon Recirculation Pumps, and Zenon Membrane Trains.
 - c. The following equipment can be reset via laptop: Raw Sewage Pumps, Peak Storage Pond Pumps, Conventional Effluent Pumps, and Aeration Blowers. The Zenon equipment will re-start on its own so long as there is sufficient air psi to operate the cyclic valves and aeration blower valves.
 - d. The operator will call Southern California Edison to get an estimated time of when the power will be restored at 800-655-4555. The operator should go thru the prompts until given the option to speak to a live operator. Once the 24hrs/ day available operator picks up the phone, the operator must identify themselves as a City of Redlands employee and request priority for power restoration due to being a wastewater treatment facility. Plant address is 1950 North Nevada Street and (Note: Operator should call every 2-3 hours to get updates of time of restoration)
 - e. Upon arrival at the wastewater treatment plant, the operator will put his safety approved ear protection on and open the generator door using the key that is hanging on the operations key board. The operator will start the plant's assessment with the standby generator to ensure that it is performing well and observe the various parameters on the generator's HMI such as: oil psi, generator coolant temp, amps being drawn by equipment.
 - f. By pressing the menu button and selecting the #1 on the standby generator main panel, the operator can view the kW amp draw, volts, and kvar by scrolling down using the arrow down button. The operator can also check the engine's performance by pressing the menu button and scrolling down using the arrow down button.
 - g. Normal oil psi: 168 psi. Low oil psi warning; 57. Low oil psi shut down; 43.

- h. Normal coolant temp. 150 to 185 degrees Celsius. High coolant temp warning: 198 degrees Celsius. High coolant temp shut down: 208 degrees Celsius. Engine warmed up: 100 degrees Celsius. Engine cooled down 150 degrees Celsius.
- i. The standby generator consumes 7.9 gal/hour per 100 kw. The standby generator can run up to 16-18 hours on 1000 gallons of diesel fuel.
- j. The operator will perform a general plant site assessment and restart the drives on the secondary clarifiers and dissolved air flotation thickeners.
- k. The main concern that the operator should focus on is compliance with the limits established by the State of California Regional Water Quality Control Board for the City of Redlands.

Note: If there is a problem with the generator not starting up a due to a blown fuse or other reason, maintenance personnel must be notified immediately. If the power outage occurs after hours directly call the on call maintenance worker. The on call maintenance worker can be reached by calling (909) 557-3376.

The following equipment needs to be reset via SCADA in order to go online after a power outage:

The following equipment requires resetting after a power outage. This applies to when the standby generator comes on due to loss of utility power and when it shuts off and transfers to utility power.

- 1) Zenon Membrane Trains all default to start delay and need to be re-started at SCADA.
 - (a) Re-start the membrane trains gradually to prevent a surge at the chlorine contact basin and to prevent a surge in amperage draw from the standby generator.
 - (b) Aeration Blowers will need to be re-started at SCADA and must be started gradually with only one blower to operate the plant while the generator is running, if there is a need for more aeration, this can be performed after all of the plant equipment has been reset and started for at least 25 minutes.
- 2) Reset Peak Pond Pumps and put back to Auto on SCADA. Verify that the flow set point to the Zenon and aeration basins is set to desired flow.
- 3) Headworks: multiple equipment failures will need to be reset on SCADA. It is critical to ensure that the influent pumps are running and the wet well level is within the operating range. The Headworks raw sewage pumps will need to be monitored to ensure that there are no glitches in the plc preventing these from running and the UPS battery will need to be checked to ensure it is not preventing the PLC from working. The online automatic bar screen will need to be reset along with the rag compactor and grit screw.

The following equipment needs to be physically checked and verified that it is operating in the automatic run mode at each station and reset:

- 1) Chlorine Contact Station: check and prime the influent and effluent sample pumps for the chlorine and turbidity analyzers, reset the GFI on sample pumps; check the PLC and UPS battery at the PLC panel for normal operation, check the dog house analyzers, check the water quality to ensure that the reclaimed water

is meeting specification to send out. If there are any issues with water quality it is best to manually close the reclaimed water valve and leave closed until any issues that develop have passed through. It will be necessary to monitor the water quality continuously in order to determine when to put the reclaimed water valve back to the normal-auto position, it is recommended that at least a half hour has passed after water quality improves to specification limits. It will be necessary to contact Mountain View Power to notify them that we will be closing our valve as a result of a power outage. They can be reached at 909-478-1738

- 2) Headworks: grit screw needs to be reset at the VFD panel; check and reset PLC, UPS battery, and VFD's as necessary. The UPS may need to be put to bypass and left in bypass until repairs can be made if the UPS battery fails.

Rag screw conveyor needs to be checked and verified that it is running and reset if necessary.

Primary clarifier flights need to be checked for proper operation and reset as needed.

Ferric chloride pump needs to be reset and re-started at the panel inside the chemical storage area.

- 3) Peak Pond Pump Station: check pumps to verify that these are running, check the dog house for normal operation of the pump VFD's. Check the UPS battery and PLC for normal operation.

- 4) Aeration Basins: check and reset the mixers as needed.

Verify that the ferric feed line is dripping at the Zenon mixed liquor distribution box.

Observe air distribution system on the aeration basin to confirm normal operation.

Check the PLC for the Zenon membrane trains and verify that it is operating normally.

Verify that the UPS battery is not displaying a red light and reset as needed by putting to bypass.

- 5) Secondary Clarifier: Restart skimming arm.

Conventional Effluent Pump station may need to be physically reset.

- 6) WAS and Primary DAFs: Restart skimming arms and recirculation pumps at both DAFs. Make sure there is an established air pad. Check digester indicator to make sure it is functioning.

- 7) Digester 1 & 2 Room: Make sure recirculation pump is running.

- 8) Digester 3: Reset recirculation pump.

- 9) Centrifuge: Load setting needs to be reset from default settings.

- 10) Flare: Start air compressor before firing up flare. Start computer.

The operator should monitor the operation of the generator throughout its operation and arrange for refueling when the fuel tank reaches 50 percent on the fuel gauge. Aaron Jenkins, Fleet Services Coordinator, can be reached during the day at extension 7568, and after normal work hours by means of an email ajenkins@cityofredlands.org.

In the event that Aaron is not available and it is an emergency

Merit Oil can be contacted at the following numbers:

Perry 909-877-4126

Office 909-877-2651

A request for 500 gallons of diesel fuel for the standby generator will be made.

The follow is a list of City of Redlands staff that must be contacted in the event of a power outage in order of priority:

Wastewater Operations Supervisor, Joseph Hamburger, work cell (909) 353-9049.

Operations:

Operations Standby Phone, cell: (909) 841-3505

Jeff Belanger, Wastewater Operator III, cell: (909) 362-3055

John Serrano, Wastewater Operator III, cell: (909) 831-4075

Blake Dorsey, Wastewater Operator III, cell: (951)-440-8221

Edgar Reyes, Wastewater Operator III, cell (424)-240-6057

Daniel Hernandez, Wastewater Operator III, cell (909)-801-4496

Maintenance:

Maintenance Standby Phone, cell: (909) 557-3376

Sean Kilday, Utilities Maintenance Foreperson, work cell (909) 557-6653

Ruben Gallardo, Plant Mechanic, cell: (909) 747-4047

David Giannini, Plant Mechanic, cell: (951) 505-8467

Alek Kunf, Plant Mechanic, cell: (909) 477-9468

Hanna Shields, Maintenance Worker, cell: (951) 265-1193

Chris Thornburg: (909) 856-4936

In the event that the Wastewater Operations Supervisor cannot be reached, contact Fernando Mata, Wastewater Operations Superintendent, work cell (909) 841-3142.

In the event the Wastewater Operations Superintendent cannot be contacted notify Utilities Operations Manager Kevin Watson, work cell (909) 725-7979.

Once the plant operator has reset the plant equipment and the utility power has been restored, the operator will have to go back out into every section of the plant and physically reset all affected equipment again.

Operations and Maintenance staff will be onsite 24 hours a day and will continue to follow this SOP until the plant has been place on permanent utility power.

Appendix C

Cogeneration Pre-Cleaning Technologies

Various Gas Cleaning Methods

Methods	Description
Iron Sponge	<ul style="list-style-type: none"> • Wood chips impregnated with iron oxide • Simple and in use for almost 150 years • Can be regenerated to some extent with oxygen • Regeneration reaction is exothermic • Requires changeout of media and landfill disposal • May require maintenance of pH, moisture, and temperature
Iron Oxide Pellets	<ul style="list-style-type: none"> • Iron Oxide coated beads or pellets • Simple system • More uniform media size and shape for more equal gas distribution • Media must be replaced and hauled for disposal • Media has potential to bind requiring use of water for removal
Biotrickling Filter	<ul style="list-style-type: none"> • Microorganisms grown within media • Water fed top to bottom and drained out • Ability to remove H₂S, NH₃, volatile fatty acids, organic odors, and select VOCs • Less expensive than most options • Media requires changeout approximately every 10 years
Scrubbing	<ul style="list-style-type: none"> • Ability to neutralize corrosive gasses using sodium hydroxide scrubbing solution • Well established technology • High removal efficiency compared with other technologies • High cost of chemicals and electricity • May require maintenance of caustic replacement • Recirculates water
Activated Carbon	<ul style="list-style-type: none"> • Granular activated carbon comes in a variety of forms to fit various applications • High amount of adsorption area per pound of media • Not selective to H₂S and may also readily remove other compounds such as volatile organics, reducing usable life of the bed • Some forms of carbon are not as effective as others in removing hydrogen sulfide • Requires replacement and disposal of spent media

Appendix D

Cogeneration Unit Cut Sheet

Technical Description

Cogeneration Unit-Container

JMC 320 GS-B.L

Mains Parallel with Island Operations & Blackstart

City of Redlands WWTP

JMC320 D825 480v

Northeast-Western Energy Systems

Full rating of the engine is for an installation at an altitude $\leq 1189\text{ft}$ and combustion air temperature $\leq 88.7^\circ\text{F}$. At air temperature $88.7^\circ\text{F} < T < 104^\circ\text{F}$ a de-rate of $0.83\%/^\circ\text{F}$ will apply. At $T > 104^\circ\text{F}$ a derate of $1.1\%/^\circ\text{F}$ will apply. Specific derate information may change upon factory order submission.

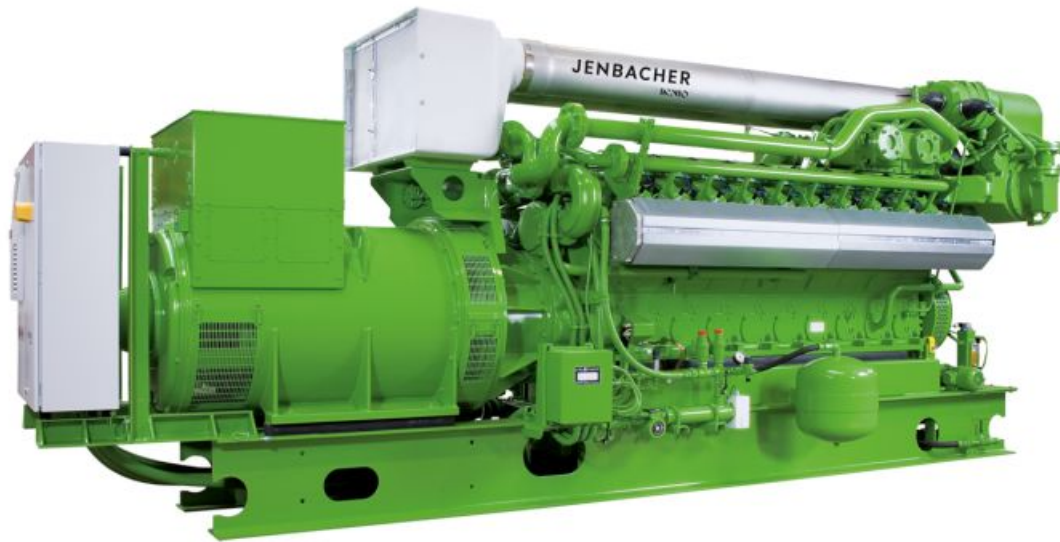

Electrical output	1062	kW el.
Thermal output	4398	MBTU/hr

Emission values
NOx < 1.1 g/bhp.hr (NO2)

0.01 Technical Data (on container)	4
Main dimensions and weights (on container)	5
Connections	5
Output / fuel consumption	5
0.02 Technical data of engine	6
Thermal energy balance	6
Exhaust gas data	6
Combustion air data	6
Sound pressure level	7
Sound power level	7
0.03 Technical data of generator	8
Reactance and time constants (saturated) at rated output	8
0.04 Technical data of heat recovery	9
General data - Hot water circuit	9
General data - Cooling water circuit	9
Exhaust gas heat exchanger	9
connection variant C	10
0.10 Technical parameters	11
1.00 Scope of supply - Module	13
1.01 Spark ignited gas engine	13
1.01.01 Engine design	13
1.01.03 Engine accessories	15
1.01.04 Standard tools (per installation)	15
1.02 Generator-low voltage	16
1.03 Module Accessories	18
1.03.01 Engine jacket water system	19
1.03.02 Automatic lube oil replenishing system incl. extension tank	20
1.05.01 Gas train <500mbar (7.3 psi)	20
1.07 Painting	21
1.11 Engine generator control panel per module- DIA.NE XT4 incl. Single synchronization of the generator breaker	21
Touch Display Screen:	22
Central engine and module control:	26
Malfunction Notice list:	27
1.11 Motor control panel – Container design	29
1.11.01 Remote messaging over MODBUS-TCP	30

JENBACHER

1.11.06 Remote Data-Transfer with DIA.NE XT4	30
1.11.25 Control Strategy and Options (Type 3 Container)	33
1.20.03 Starting system	35
1.20.05 Electric jacket water preheating	36
1.20.08 Flexible connections	36
2.00 Electrical equipment	36
2.02 Grid monitoring device	36
2.04 Generator Low Voltage switchgear (for container design)	38
2.12 Gas warning device	38
2.13 Smoke warning device	39
3.01 Lube oil system	39
3.03.01 Exhaust gas silencer	39
3.10.03 Cooling system – dual-circuit radiator	40
3.20 Container	40
3.50 Power and control cable	42
3.71 Vibration Switch	42
3.73 Seismic Protection - Container	42
4.00 Delivery, installation, and commissioning	42
4.01 Carriage	42
4.02 Unloading	42
4.03 Assembly and installation	42
4.04 Storage	42
4.05 Emission measurement with exhaust gas analyzer	43
5.01 Limits of delivery - Container	43
5.02 Factory tests and inspections	43
5.02.01 Engine tests	43
5.02.02 Generator tests	44
5.03 Documentation	44

0.01 Technical Data (on container)

			100%	75%	50%
Power input	[2]	MBTU/hr	9,387	7,292	5,204
Gas volume	*)	scfhr	21,629	16,801	11,990
Mechanical output	[1]	bhp	1,468	1,101	735
Electrical output	[4]	kW el.	1,062	795	527
Recoverable thermal output (calculated with Glykol 37%)					
~ Intercooler 1st stage	[9]	MBTU/hr	593	229	66
~ Lube oil		MBTU/hr	611	536	464
~ Jacket water		MBTU/hr	1,133	942	778
~ Exhaust gas cooled to 356 °F		MBTU/hr	2,061	1,785	1,300
Total recoverable thermal output	[5]	MBTU/hr	4,398	3,491	2,608
Heat to be dissipated (calculated with Glykol 37%)					
~ Intercooler 2nd stage		MBTU/hr	178	98	45
~ Lube oil		MBTU/hr	---	---	---
~ Surface heat	ca. [7]	MBTU/hr	336	~	~
Spec. fuel consumption of engine electric					
Spec. fuel consumption of engine electric	[2]	BTU/kWel.hr	8,838	9,175	9,881
Spec. fuel consumption of engine					
Spec. fuel consumption of engine	[2]	BTU/bhp.hr	6,392	6,623	7,081
Lube oil consumption	ca. [3]	gal/hr	0.10	~	~
Electrical efficiency			38.6%	37.2%	34.5%
Thermal efficiency			46.8%	47.9%	50.1%
Total efficiency	[6]		85.5%	85.1%	84.7%
Hot water circuit:					
Forward temperature		°F	194.0	182.9	172.0
Return temperature		°F	140.0	140.0	140.0
Hot water flow rate		GPM	182.6	182.6	182.6
Fuel gas LHV					
Fuel gas LHV		BTU/scft	434		

*) approximate value for pipework dimensioning

□ Explanations: see 0.10 - Technical parameters

All heat data is based on standard conditions according to attachment 0.10. Deviations from the standard conditions can result in a change of values within the heat balance and must be taken into consideration in the layout of the cooling circuit/equipment (intercooler; emergency cooling; ...). In the specifications in addition to the general tolerance of $\pm 8\%$ on the thermal output a further reserve of $+5\%$ is recommended for the dimensioning of the cooling requirements.

Main dimensions and weights (on container)

Length	in	~ 490
Width	in	99-118
Height	in	~ 110
Weight empty	lbs	~ 64,540
Weight filled	lbs	~ 67,840

Connections

Hot water inlet and outlet [A/B]	in/lbs	3"/145
Exhaust gas outlet [C]	in/lbs	10"/145
Fuel gas connection (on container) [D]	in	6"/232
Fresh oil connection	G	28x2"
Waste oil connection	G	28x2"
Cable outlet	in	31.5x15.7
Condensate drain	in	0.7

Output / fuel consumption

ISO standard fuel stop power ICFN	bhp	1,468
Mean effe. press. at stand. power and nom. speed	psi	218
Fuel gas type		Biogas
Based on methane number Min. methane number	MN	135 117 d)
Compression ratio	Epsilon	12.5
Min./Max. fuel gas pressure at inlet to gas train	psi	1.16 - 2.9 c)
Max. rate of gas pressure fluctuation	psi/sec	0.145
Maximum Intercooler 2nd stage inlet water temperature	°F	140
Spec. fuel consumption of engine	BTU/bhp.hr	6,392
Specific lube oil consumption	g/bhp.hr	0.22
Max. Oil temperature	°F	~ 189
Jacket-water temperature max.	°F	~ 203
Filling capacity lube oil (refill)	gal	~ 90

c) Lower gas pressures upon inquiry

d) based on methane number calculation software AVL 3.2

0.02 Technical data of engine

Manufacturer		JENBACHER
Engine type		J 320 GS-D825
Working principle		4-Stroke
Configuration		V 70°
No. of cylinders		20
Bore	in	5.31
Stroke	in	6.69
Piston displacement	cu.in	2,970
Nominal speed	rpm	1,800
Mean piston speed	in/s	402
Length	in	131
Width	in	53
Height	in	81
Weight dry	lbs	11,464
Weight filled	lbs	12,566
Moment of inertia	lbs-ft ²	204.35
Direction of rotation (from flywheel view)		left
Radio interference level to VDE 0875		N
Starter motor output	kW	7
Starter motor voltage	V	24

Thermal energy balance

Power input	MBTU/hr	9,387
Intercooler	MBTU/hr	771
Lube oil	MBTU/hr	611
Jacket water	MBTU/hr	1,133
Exhaust gas cooled to 356 °F	MBTU/hr	2,061
Exhaust gas cooled to 212 °F	MBTU/hr	2,549
Surface heat	MBTU/hr	191

Exhaust gas data

Exhaust gas temperature at full load	[8]	°F	936
Exhaust gas temperature at bmep= 163.2 [psi]		°F	~ 1011
Exhaust gas temperature at bmep= 108.8 [psi]		°F	~ 1042
Exhaust gas mass flow rate, wet		lbs/hr	13,091
Exhaust gas mass flow rate, dry		lbs/hr	12,143
Exhaust gas volume, wet		scfhr	163,819
Exhaust gas volume, dry		scfhr	144,962
Max.admissible exhaust back pressure after engine		psi	0.870

Combustion air data

Combustion air mass flow rate		lbs/hr	12,046
Combustion air volume		SCFM	2,488
Max. admissible pressure drop at air-intake filter		psi	0.145

base for exhaust gas data: natural gas: 100% CH₄; biogas 65% CH₄, 35% CO₂

Sound pressure level

Aggregate a)		dB(A) re 20µPa	99
31,5	Hz	dB	81
63	Hz	dB	93
125	Hz	dB	95
250	Hz	dB	92
500	Hz	dB	95
1000	Hz	dB	93
2000	Hz	dB	92
4000	Hz	dB	90
8000	Hz	dB	93
Exhaust gas b)		dB(A) re 20µPa	122
31,5	Hz	dB	97
63	Hz	dB	108
125	Hz	dB	118
250	Hz	dB	110
500	Hz	dB	113
1000	Hz	dB	114
2000	Hz	dB	117
4000	Hz	dB	115
8000	Hz	dB	114

Sound power level

Aggregate	dB(A) re 1pW	120
Measurement surface	ft ²	1,292
Exhaust gas	dB(A) re 1pW	130
Measurement surface	ft ²	67.60

a) average sound pressure level on measurement surface in a distance of 3.28ft (converted to free field) according to DIN 45635, precision class 3.

b) average sound pressure level on measurement surface in a distance of 3.28ft according to DIN 45635, precision class 2. The spectra are valid for aggregates up to bmep=217.55661 psi. (for higher bmep add safety margin of 1dB to all values per increase of 15 PSI pressure).

Engine tolerance ± 3 dB

0.03 Technical data of generator

Manufacturer		STAMFORD e)
Type		PE 734 C e)
Type rating	kVA	1,536
Driving power	bhp	1,468
Ratings at p.f.= 1.0	kW	1,062
Ratings at p.f. = 0.8	kW	1,053
Rated output at p.f. = 0.8	kVA	1,316
Rated reactive power at p.f. = 0.8	kVAr	789
Rated current at p.f. = 0.8	A	1,583
Frequency	Hz	60
Voltage	V	480
Speed	rpm	1,800
Permissible overspeed	rpm	2,250
Power factor (lagging - leading) (UN)		0,8 - 1,0
Efficiency at p.f.= 1.0		97.0%
Efficiency at p.f. = 0.8		96.1%
Moment of inertia	lbs-ft ²	861.54
Mass	lbs	6,541
Radio interference level to EN 55011 Class A (EN 61000-6-4)		N
Cable outlet		~
Ik" Initial symmetrical short-circuit current	kA	16.14
Is Peak current	kA	41.07
Insulation class		H
Temperature rise (at driving power)		F
Maximum ambient temperature	°F	104

Reactance and time constants (saturated) at rated output

xd direct axis synchronous reactance	p.u.	2.235
xd' direct axis transient reactance	p.u.	0.139
xd'' direct axis sub transient reactance	p.u.	0.097
x2 negative sequence reactance	p.u.	0.146
Td'' sub transient reactance time constant	ms	10
Ta Time constant direct-current	ms	20
Tdo' open circuit field time constant	s	2.20

e) JENBACHER reserves the right to change the generator supplier and the generator type. The contractual data of the generator may thereby change slightly. The contractual produced electrical power will not change.

0.04 Technical data of heat recovery

General data - Hot water circuit

Total recoverable thermal output	MBTU/hr	4,398
Return temperature	°F	140.0
Forward temperature	°F	194.0
Hot water flow rate	GPM	182.6
Design pressure of hot water	lbs	145
min. operating pressure	psi	51.0
max. operating pressure	psi	131.0
Pressure drop hot water circuit	psi	14.50
Maximum Variation in return temperature	°F	+0/-21
Max. rate of return temperature fluctuation	°F/min	18

General data - Cooling water circuit

Heat to be dissipated (calculated with Glykol 37%)	MBTU/hr	178
Return temperature	°F	140
Cooling water flow rate	GPM	110
Design pressure of cooling water	lbs	145
min. operating pressure	psi	7.0
max. operating pressure	psi	73.0
Loss of nominal pressure of cooling water	psi	~
Maximum Variation in return temperature	°F	+0/-21
Max. rate of return temperature fluctuation	°F/min	18

Exhaust gas heat exchanger

Type	shell-and-tube
------	----------------

PRIMARY:

Exhaust gas pressure drop approx	psi	0.22
Exhaust gas connection	in/lbs	10"/145

SECONDARY:

Pressure drop hot water circuit	psi	2.90
Hot water connection	in/lbs	4"/145

The final pressure drop will be given after final order clarification and must be taken from the P&ID order documentation.

Hot water circuit (calculated with Glykol 37%)

Recoverable thermal output = 4,398 MBTU/hr
(±8 % tolerance +5 % reserve for cooling requirements)
Hot water flow rate = 182.6 GPM

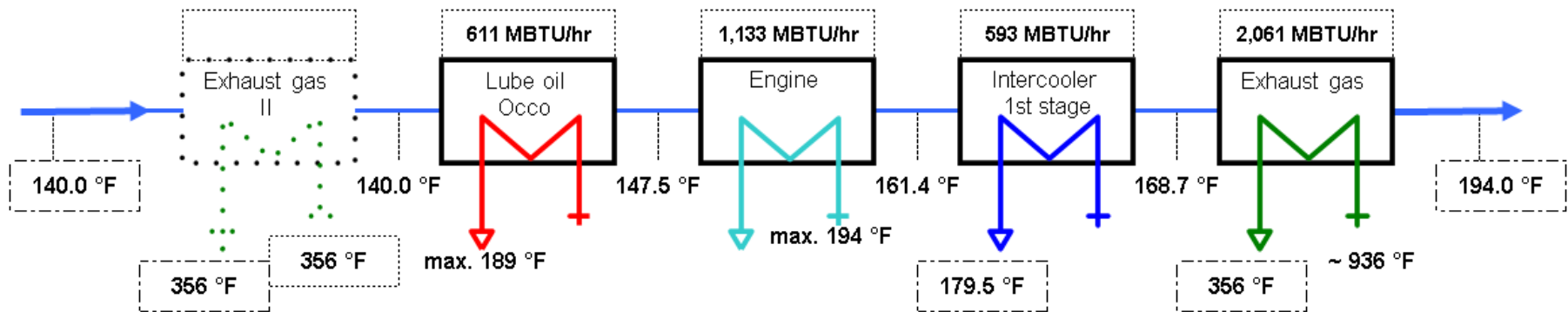

Low Temperature circuit (calculated with Glykol 37%)

Heat to be dissipated = 178 MBTU/hr
(±8 % tolerance +5 % reserve for cooling requirements)
Cooling water flow rate = 110.1 GPM

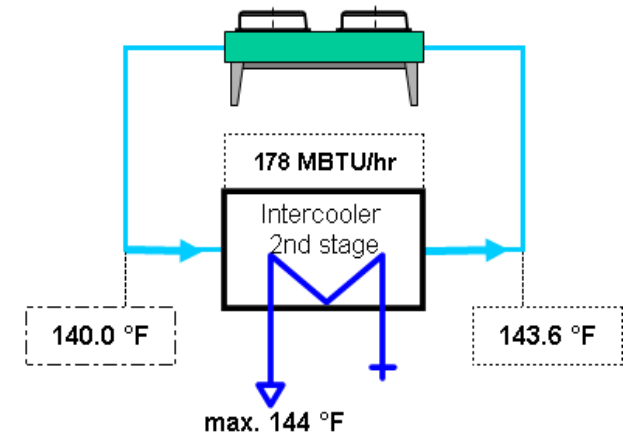

0.10 Technical parameters

All data in the technical specification are based on engine full load (unless stated otherwise) at specified temperatures as well as the methane number and subject to technical development and modifications. For isolated operation an output reduction may apply according to the block load diagram. Before being able to provide exact output numbers, a detailed site load profile needs to be provided (motor starting curves, etc.).

All pressure indications are to be measured and read with pressure gauges (psi.g.).

- [1] At nominal speed and standard reference conditions ICFN according to ISO 3046-1, respectively.
- [2] According to ISO 3046-1, respectively, with a tolerance of **+5 %**.
Efficiency performance is based on a new unit (immediately upon commissioning). Effects of degradation during normal operation can be mitigated through regular service and maintenance work.
reference value --> 65%CH4 / 35%CO2
- [3] Average value between oil change intervals according to maintenance schedule, without oil change amount
- [4] At p. f. = 1.0 according to VDE 0530 REM / IEC 34.1 with relative tolerances, all direct driven pumps are included
- [5] Total output with a tolerance of $\pm 8 \%$
- [6] According to above parameters [1] through [5]
- [7] As a guiding value at p.f. 0.8 and only valid for (engine, generator, TCM). Other peripheral equipment is not considered.
- [8] Exhaust temperature with a tolerance of $\pm 8 \%$
Note: an optimized operating mode to minimize methane slip can result in changed exhaust gas data (exhaust gas temperature, NOx emissions, etc.) and must be taken into account in the design of the exhaust gas aftertreatment
- [9] Intercooler heat on:
 - * **standard conditions** - If the turbocharger design is done for air intake temperature $> 86^{\circ}\text{F}$ w/o de-rating, the intercooler heat of the 1st stage need to be increased by 2%/K starting from 77°F . Deviations between $77 - 86^{\circ}\text{F}$ will be covered with the standard tolerance.
 - * **Hot Country application (V1xx)** - If the turbocharger design is done for air intake temperature $> 104^{\circ}\text{F}$ w/o de-rating, the intercooler heat of the 1st stage need to be increased by 2%/K starting from 95°F . Deviations between $95 - 104^{\circ}\text{F}$ will be covered with the standard tolerance.

Radio interference level

The ignition system of the gas engines complies the radio interference levels of CISPR 12 and EN 55011 class B, (30-75 MHz, 75-400 MHz, 400-1000 MHz) and (30-230 MHz, 230-1000 MHz), respectively.

Definition of output

- ISO-ICFN continuous rated power:
Net break power that the engine manufacturer declares an engine is capable of delivering continuously, at stated speed, between the normal maintenance intervals and overhauls as required by the manufacturer. Power determined under the operating conditions of the manufacturer's test bench and adjusted to the standard reference conditions.
- Standard reference conditions:
Barometric pressure: 14.5 psi (1000 mbar) or 328 ft (100 m) above sea level

Air temperature: 77°F (25°C) or 298 K
Relative humidity: 30 %

- Volume values at standard conditions (fuel gas, combustion air, exhaust gas)
Pressure: 1 atmosphere (1013.25 mbar)
Temperature: 32°F (0°C)

Loss of engine performance

a) Performance reduction due to gas quality

If the reference methane number is not reached and the knock control responds, the ignition timing at full performance is adjusted in conjunction with the engine management system; only then is performance reduced.

H₂ admixtures in the range of 3–5 Vol% into the natural gas network are generally regarded as non-critical. Prerequisites for this are rates of change according to TA 1000-0300, as well as the knock resistance (minimum methane number) of the natural gas-H₂ mixture according to the specification. For reliable compliance with required NO_x emissions, the JENBACHER LEANOX^{plus} control is recommended (measurement of NO_x emissions and correction of the LEANOX controller). Higher H₂ addition rates into the natural gas network must be assessed on a project-specific basis.

b) Performance reduction due to voltage and frequency limits

If the voltage and frequency limits for generators specified in IEC 60034-1 Zone A are exceeded, performance is reduced.

c) Performance reduction due to environmental conditions

Standard rating of the engines is for an installation at an altitude ≤ **1189 ft** and combustion air temperature ≤ **88 °F (T1)**

Engine room outlet temperature: **122°F (T2)** -> engine stop

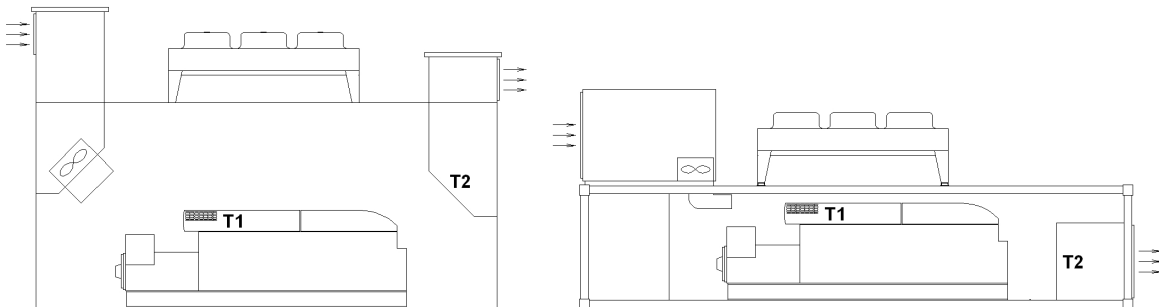

The minimum recommended air change ratio (C) must be observed to maintain the required air quality and prevent unwanted gas accumulations (refer to Section ⇒ Potentially explosive Atmospheres as per TA1100-0110). The calculation is based on TA 1100-0110 and is $C_{\min} = 50h^{-1}$ for JENBACHER modules.

Parameters for the operation of JENBACHER gas engines

The genset fulfills the limits for mechanical vibrations according to ISO 8528-9.

The following "Technical Instruction of JENBACHER" forms an integral part of a contract and must be strictly observed: **TA 1000-0004**, **TA 1100 0110**, **TA 1100-0111**, and **TA 1100-0112**.

Transport by rail should be avoided. See **TA 1000-0046** for further details

Failure to adhere to the requirements of the above-mentioned TA documents can lead to engine damage and may result in loss of warranty coverage.

Parameters for the operation of control unit and the electrical equipment

Relative humidity 50% by maximum temperature of 104°F.

Altitude up to 2000m above the sea level.

Parameters for using a gas compressor

The gas quantity indicated under the technical data refers to standard conditions with the given calorific value. The actual volume flow (under operating conditions) has to be considered for dimensioning the gas compressor and each gas feeding component – it will be affected by:

- Actual gas temperature (limiting temperature according to TA 1000-0300)
- Gas humidity (limiting value according to TA 1000-0300)
- Gas Pressure
- Calorific value variations (can be equated with methane (CH₄) variations in the case of biogas)
- The gas compressor is designed for a max. relative under pressure of 15 mbar(g) (0.22 psi) and a inlet temperature of 40°C (104°F) , if within scope of supply JENBACHER.

1.00 Scope of supply - Module

Design:

The module is built as a compact package. The engine and generator are mounted on a common base when a low voltage generator is specified (<1000 V). In case of a medium voltage generator the engine base is bolted to the generator base.

The Engine output shafting is connected through a coupling to the generator. To provide the best possible isolation from the transmission of vibrations, the engine rests on the engine base-frame by means of anti-vibration mounts. The remaining vibrations are eliminated by mounting the complete module on isolating pads (e.g. Sylomer). This, in principle, allows for placing of the module to be directly on any floor capable of carrying the static load.

1.01 Spark ignited gas engine

Four-stroke, air/gas mixture turbocharged, aftercooled, with high performance ignition system and electronically controlled air/gas mixture system.

The engine is equipped with the most advanced

LEANOX® LEAN-BURN COMBUSTION SYSTEM

developed by JENBACHER.

1.01.01 Engine design

Engine block

Single-piece crankcase and cylinder block made of special casting, crank case covers for engine inspection, welded steel oil pan.

Crankshaft and main bearings

Drop-forged, precision ground, surface hardened, statically and dynamically balanced; main bearings (upper bearing shell: 3-material bearing / lower bearing shell: sputter bearing) arranged between crank pins, drilled oil passages for forced-feed lubrication of connecting rods.

Vibration damper

Maintenance free viscous damper

Flywheel

With ring gear for starter motor

Pistons

Single piece, made of light metal alloy, with piston ring carrier and oil passages for cooling; piston rings made of high-quality material, main combustion chamber specially designed for lean burn operation.

Connecting rods

Drop-forged, heat-treated, big end diagonally split and toothed. Big end bearings (upper bearing shell: sputter bearing / lower bearing shell: grooved bearing) and connecting rod bushing for piston pin.

Cylinder liner

Chromium alloy gray cast iron, wet, individually replaceable.

Cylinder head

Specially designed and developed for JENBACHER-lean burn engines with optimized fuel consumption and emissions; water cooled, made of special casting, individually replaceable; Valve seats and valve guides and spark plug sleeves individually replaceable; exhaust and inlet valve made of high-quality material.

Crankcase breather

Connected to combustion air intake system

Valve train

Camshaft, with replaceable bushings, driven by crankshaft through intermediate gears, valve lubrication by splash oil through rocker arms.

Combustion air/fuel gas system

Motorized carburetor for automatic adjustment according fuel gas characteristic. Exhaust driven turbocharger, mixture manifold with bellows, water-cooled intercooler, throttle valve and distribution manifolds to cylinders.

Ignition system

Most advanced, fully electronic high-performance ignition system, external ignition control.

Lubricating system

Gear-type lube oil pump to supply all moving parts with filtered lube oil, pressure control valve, pressure relief valve and full-flow filter cartridges. Cooling of the lube oil is arranged by a heat exchanger.

Engine cooling system

Jacket water pump complete with distribution pipework and manifolds.

Exhaust system

Turbocharger and exhaust manifold

Exhaust gas temperature measuring

Thermocouple for each cylinder

Electric actuator

For electronic speed and output control

Electronic speed monitoring for speed and output control

By magnetic inductive pick up over ring gear on flywheel

Starter motor

Engine mounted electric starter motor

1.01.03 Engine accessories

Insulation of exhaust manifold:

Insulation of exhaust manifold is easily installed and removed

Sensors at the engine:

- Jacket water temperature sensor
- Jacket water pressure sensor
- Lube oil temperature sensor
- Lube oil pressure sensor
- Mixture temperature sensor
- Charge pressure sensor
- Minimum and maximum lube oil level switch
- Exhaust gas thermocouple for each cylinder
- Knock sensors
- Gas mixer / gas dosing valve position reporting.

Actuator at the engine:

- Actuator - throttle valve
- Bypass-valve for turbocharger
- Control of the gas mixer / gas dosing valve

1.01.04 Standard tools (per installation)

The tools required for carrying out the most important maintenance work are included in the scope of supply and delivered in a toolbox.

1.02 Generator-low voltage

The 2-bearing generator consists of the main generator (built as rotating field machine), the exciter machine (built as rotating armature machine) and the digital excitation system.

The digital regulator is powered by an auxiliary winding at the main stator or a PMG system

Main components

- Enclosure of welded steel construction
- Stator core consist of thin insulated electrical sheet metal with integrated cooling channels.
- Stator winding with 2/3 Pitch
- Rotor consists of shaft with shrunken laminated poles, Exciter rotor, PMG (depending on Type) and fan.
- Damper cage
- Excitation unit with rotating rectifier diodes and overvoltage protection
- Dynamically balanced as per ISO 1940, Balance quality G2,5
- Drive end bracket with re greaseable antifriction bearing
- Non-drive end bracket with re grease antifriction bearing
- Cooling IC01 - open ventilated, air entry at non-drive end , air outlet at the drive end side
- Main terminal box includes main terminals for power cables
- Regulator terminal box with auxiliary terminals for thermistor connection and regulator.
- Anti-condensation heater
- 3 PT100 for winding temperature monitoring+3 PT100 Spare
- 2 PT100 for bearing temperature monitoring

Option:

Current transformer for protection and measuring in the star point

xx/1A, 10P10 15VA , xx/1A, 1FS5, 15VA

Electrical data and features

- Standards: IEC 60034, EN 60034, VDE 0530, ISO 8528-3, ISO 8528-9
- Voltage adjustment range: +/- 10 % of rated voltage (continuous)
- Frequency: -6/+4% of rated frequency
- Overload capacity: 10% for one hour within 6 hours, 50% for 30 seconds
- Asymmetric load : max. 8% I₂ continuous, in case of fault I₂ x t=20
- Altitude: < 1000m
- Max permitted generator intake air temperature: 5°C - 40°C
- Max. relative air humidity: 90%
- Voltage curve THD Ph-Ph: <3,5% at idle operation and <5% at full load operation with linear symmetrical load
- Generator suitable for parallel operating with the grid and other generators
- Sustained short circuit current at 3-pole terminal short circuit: minimum 3 times rated current for 5 seconds.
- Over speed test with 1.2 times of rated speed for 2 minutes according to IEC 60034

Digital Excitation system ABB Unitrol 1010 mounted within the AVR Terminal box with following features:

JENBACHER

- Compact and robust Digital Excitation system for Continuous output current up to 10 A (20A Overload current 10s)
- Fast AVR response combined with high excitation voltage improves the transient stability during LVRT events.
- The system has free configurable measurement and analog or digital I/Os. The configuration is done via the local human machine interface or CMT1000
- Power Terminals
 - 3 phase excitation power input from PMG or auxiliary windings
 - Auxiliary power input 24VDC
- Excitation output
- Measurement terminals: 3 phase machine voltage, 1 phase network voltage, 1 phase machine current
- Analog I/Os: 2 outputs / 3 inputs (configurable), +10 V / -10 V
- Digital I/O: 4 inputs only (configurable), 8 inputs / outputs (configurable)
- Serial fieldbus: RS485 for Modbus RTU or VDC (Reactive power load sharing for up to 31 JENBACHER engines in island operation), CAN-Bus for dual channel communication
- Regulator Control modes: Bump less transfer between all modes
 - Automatic Voltage Regulator (AVR) accuracy 0,1% at 25°C ambient temperature
 - Field Current Regulator (FCR)
 - Power Factor Regulator (PF)
 - Reactive Power Regulator (VAR)
- Limiters: Keeping synchronous machines in a safe and stable operation area
 - Excitation current limiter (UEL min / OEL max)
 - PQ minimum limiter
 - Machine current limiter
 - V / Hz limiter
 - Machine voltage limiter
- Voltage matching during synchronization
- Rotating diode monitoring
- Dual channel / monitoring: Enables the dual channel operation based on self diagnostics and setpoint follow up over CAN communication. As Option available
- Power System Stabilizer (PSS) is available as option. Compliant with the standard IEEE 421.5-2005 2A / 2B, the PSS improves the stability of the generator over the highest possible operation range.
- Computer representation for power system stability studies: ABB 3BHS354059 E01
- Certifications: CE, cUL certification according UL 508c (compliant with CSA), DNV Class B,
- **Commissioning and maintenance Tool CMT1000** (for trained commissioning/ maintenance personal)
- With this tool the technician can setup all parameters and tune the PID to guarantee stable operation. The CMT1000 software allows an extensive supervision of the system, which helps the user to identify and locate problems during commissioning on site. The CMT1000 is connected to the target over USB or Ethernet port, where Ethernet connection allows remote access over 100 m.
- Main window
 - Indication of access mode and device information.
 - Change of parameter is only possible in CONTROL access mode.
 - LED symbol indicates that all parameter is stored on nonvolatile memory.
- Setpoint adjust window
 - Overview of all control modes, generator status, active limiters status and alarms.
 - Adjust set point and apply steps for tuning of the PID.
- Oscilloscope
- 4 signals can be selected out of 20 recorded channels. The time resolution is 50ms. Save files to your PC for further investigation.

- Measurement
 - All measurements on one screen.

Routine Test

Following routine tests will be carried out by the generator manufacturer

- Measuring of the DC-resistance of stator and rotor windings
- Check of the function of the fitted components (e.g. RTDs, space heater etc.)
- Insulation resistance of the following components
 - Stator winding, rotor winding
 - Stator winding RTDs
 - Bearing RTDs
 - Space heater
- No Load saturation characteristic (remanent voltage)
- Stator voltage unbalance
- Direction of rotation, phase sequence
- High voltage test of the stator windings ($2 \times U_{nom.} + 1000 \text{ V}$) and the rotor windings (min. 1500 V)

1.03 Module Accessories

Base frame

Common Base Frame fabricated with welded structural steel. Frame to mount the engine, jacket water heat exchangers, pumps, and engine auxiliaries, as well as generator.

Coupling

Engine to Generator coupling is provided. The coupling isolates the major sub-harmonics of engine alternating torque from generator.

Coupling housing

Provided for Coupling

Anti-vibration mounts

2 sets of isolation, one is arranged between engine block assembly and base frame. The second is via insulating pads (SYLOMER) for placement between base frame and foundation, delivered loose.

Exhaust gas connection

A flanged connection is provided that collects the exhaust gas turbocharger output flows, includes flexible pipe connections (compensators) to compensate for heat expansions and vibrations.

Combustion air filter

A Dry type air filter with replaceable filter cartridges is fitted. The assembly includes flexible connections to the fuel mixer/carburetor and service indicator.

Interface panel (M1 cabinet)

Totally enclosed sheet steel cubicle with hinged doors, pre-wired to terminals, ready to operate. All Cable entry will be via bottom mounted cable gland plates.

Painting: RAL 7035

Protection: External NEMA 3 (IP 54), Internal IP 20 (protection against direct contact with live parts)

Cabinet design is according to IEC 439-1 (EN 60 439-1/1990) and DIN VDE 0660 part 500, respectively.
Ambient temperature 41 - 104 °F (5 - 40 °C), Relative humidity 70%

Dimensions:

- Height: 1000 mm (39 in)
- Width: 1000 mm (39 in)
- Depth: 300 mm (12 in)

Control Power Source: The starter batteries and the cabinet mounted battery chargers will provide the power source for this enclosure.

Interface Panel contents and control functions:

- The cabinet houses the unit Battery Charger and primary 24VDC Control Power Distribution (breakers, fuses, and terminals) from the unit Batteries
- Distributed PLC Input and Output cards, located in the cabinet, gather all Engine and Generator Control I/O. These cards transmit data via data bus interface to the central engine control of the module control panel located in the A1 cabinet. Data bus is via CAN and B&R Proprietary Data Highway (Data Cables provided by JENBACHER)
- Speed monitoring relays for protection are provided.
- Gas Train I/O Collection, including interface relays and terminals for gas train shutoff valves.
- Transducer for generator functions, such as excitation voltage.
- Door Mounted Emergency Stop Switch with associated Emergency Stop Loop interface relays.
- Miscellaneous control relays, contacts, fuses, etc. for additional control valves, and auxiliaries.
- Interface Terminal Strips

Skid Mounted 3 Phase Devices are Powered by 3 x 480/277 V, 60 Hz, 50 A

AC Power for engine mounted auxiliaries (heater, pumps, etc.) are routed through a separate J-box mounted on the side M1 cabinet (Box E1). This is done to maintain signal segregation (AC from control)

NOTE: Generator Current Transformer wiring is connected directly to the Generator and does NOT pass through the M1 cabinet.

1.03.01 Engine jacket water system

Closed cooling circuit, consisting of:

- Expansion tank
- Filling device (check and pressure reducing valves, pressure gauge)
- Safety valve(s)
- Thermostatic valve
- Required pipework on module
- Vents and drains
- Jacket water pump, including check valve

- Jacket water preheat device

1.03.02 Automatic lube oil replenishing system incl. extension tank

Automatic lube oil replenishing system:

Includes float valve in lube oil feed line, including inspection glass. Electric monitoring system will be provided for engine shut-down at lube oil levels "MINIMUM" and "MAXIMUM". Solenoid valve in oil feed line is only activated during engine operation. Manual override of the solenoid valve, for filling procedure during oil changes is included.

Oil drain

By set mounted cock

Oil sump extension tank 79.3 gal

To increase the time between oil changes

Aftercooling oil pump:

Mounted on the module base frame; it is used for the aftercooling of the turbocharger; period of operation of the pump is 15 minutes from engine stop.

Consisting of:

- Oil pump 250 W, 480/277 V
- Oil filter
- Necessary pipework

1.05.01 Gas train <500mbar (7.3 psi)

Consisting of:

- Manual shut off valve
- Gas filter, filter fineness <3 µm
- Pressure gauge with push button valve
- Gas admission pressure regulator
- Solenoid valves
- Leakage detector
- Gas pressure switch (min.)
- TEC JET
- Gas flow meter (option)
- p/t compensation (option)

The gas train complies with DIN - DVGW regulations.

The gas train complies with NFPA37 (vent lines by others)

1.07 Painting

- Quality: Oil resistant prime layer
Synthetic resin varnish finishing coat
- Color:

Engine:	RAL 6018 (green)
Base frame:	RAL 6018 (green)
Generator:	RAL 6018 (green)
Module interface panel:	RAL 7035 (light grey)
Control panel:	RAL 7035 (light grey)

1.11 Engine generator control panel per module- DIA.NE XT4 incl. Single synchronization of the generator breaker

Dimensions:

- Height: 91 in (including 8 in pedestal *)
- Width: 32 -48 in*
- Depth: 24 in *

Protection class:

- external IP42
- Internal IP 20 (protection again direct contact with live parts)

*) Control panels will be dimensioned on a project specific basis. Actual dimensions will be provided in the preliminary documentation for the project.

Control supply voltage from starter and control panel batteries: 24V DC

Auxiliaries power supply: (from provider of the auxiliary supply)
3 x **480/277 V, 60 Hz**

Consisting of:

Motor - Management - System DIA.NE

JENBACHER

Setup:

- a) Touch display visualization
- b) Central engine and unit control

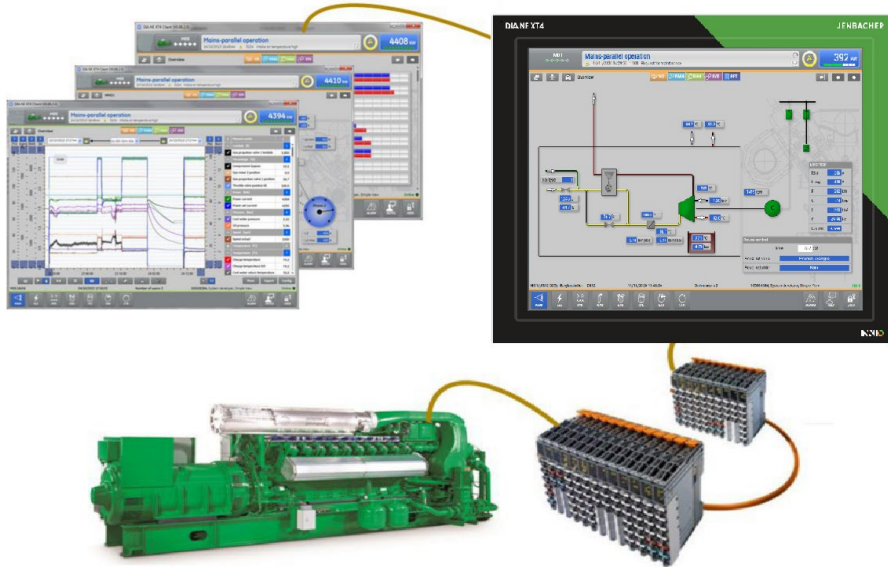

Touch Display Screen:

15" Industrial color graphic display with resistive touch.

Protection class of DIA.NE XT panel front: IP 65

The screen shows a clear and functional summary of the measurement values and simultaneously shows a graphical summary.

Operation is via the screen buttons on the touch screen

Numeric entries (set point values, parameters...) are entered on the touch numeric pad or via a scroll bar.

Determination of the operation mode and the method of synchronization via a permanently displayed button panel on the touch screen.

Main screens (examples):

Main: Display of the overview, auxiliaries' status, engine start and operating data.

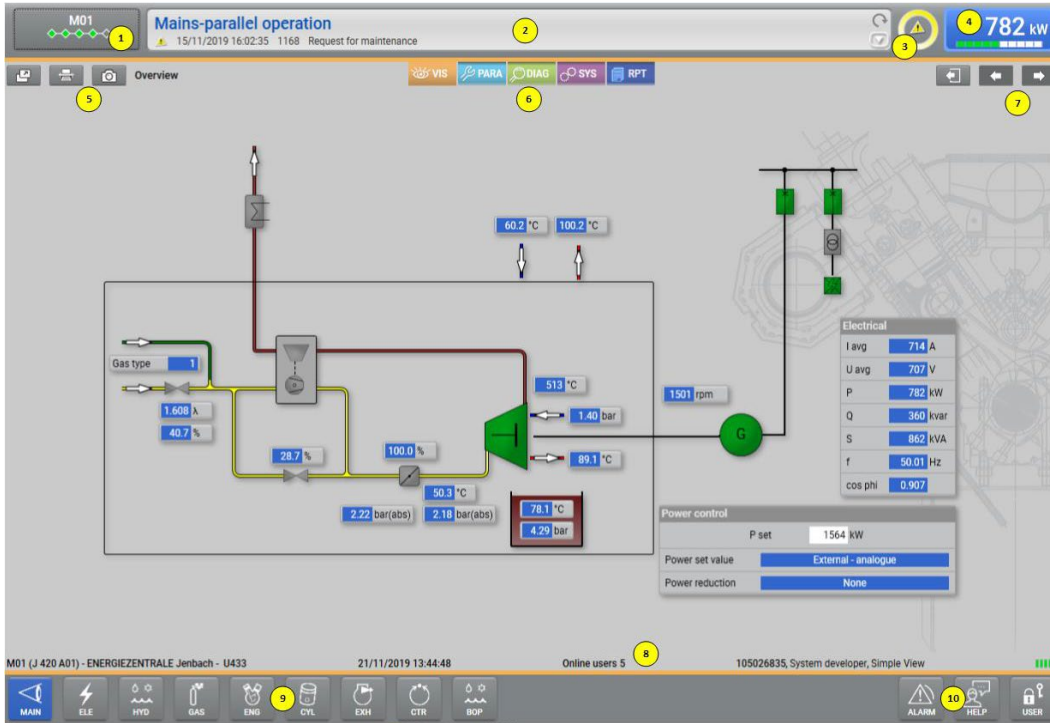

ELE: Display of the generator connection with electrical measurement values and synchronization status

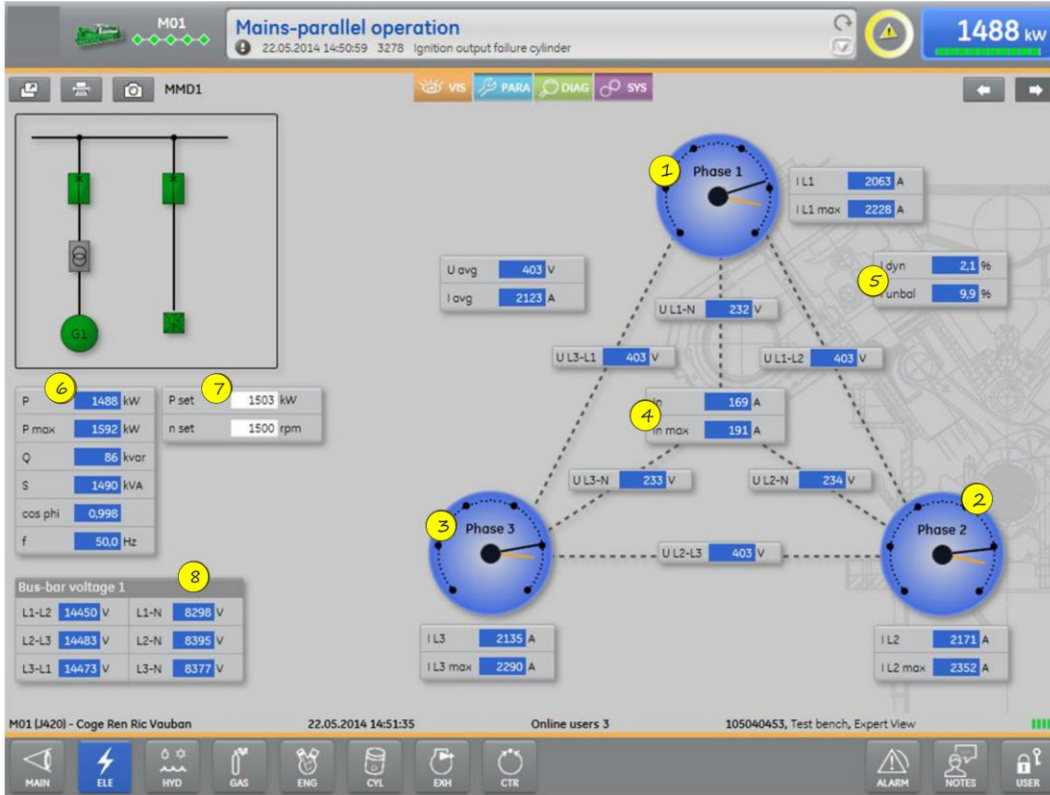

Trending

Trend with 100ms resolution

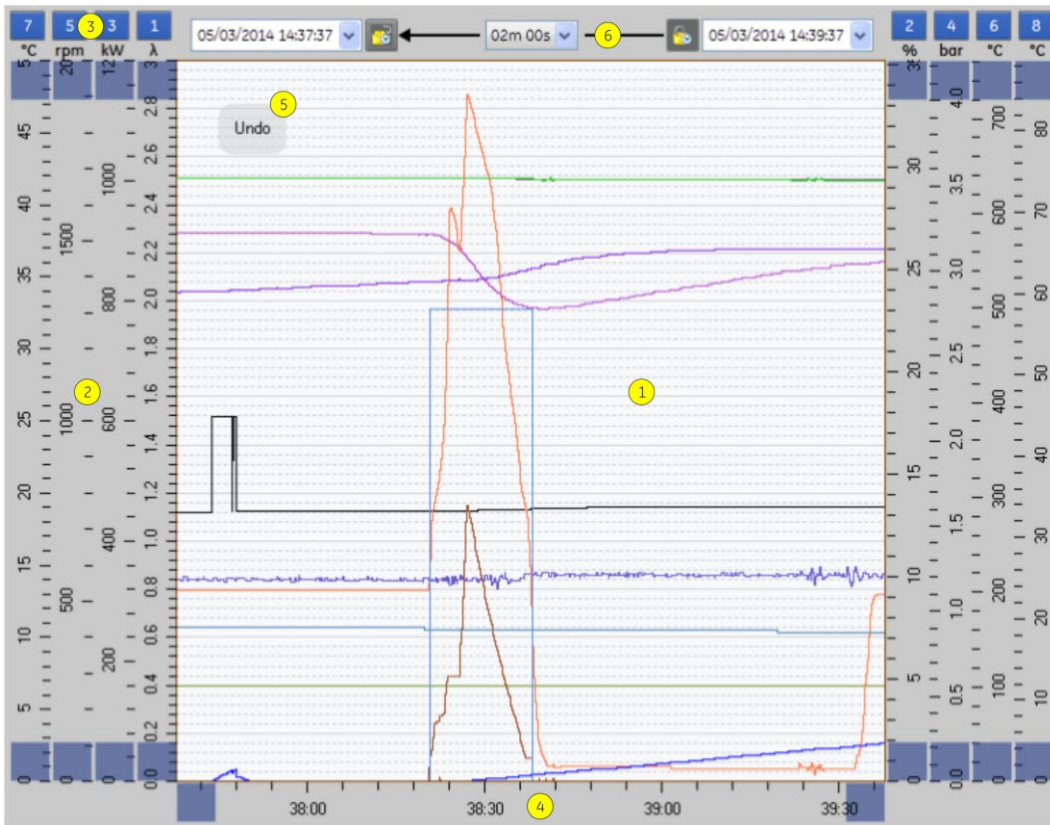

Measurement values:

- 500 data points are stored
- Measurement interval = 100ms
- Raw data availability with 100ms resolution: 3 hours + max. 50.000.000 changes in value at shut down (60 mins per shut down)
- Compression level 1: min, max, and average values with 1000ms resolution: 1 day
- Compression level 2: min, max, and average values with 30s resolution: 1 month
- Compression level 3: min, max, and average values with 10min resolution: 10 years

Messages:

1.000.000 message events

Actions (operator control actions):

100.000 Actions

System messages:

100.000 system messages

Central engine and module control:

An industrial PC- based modular industrial control system for module and engine sequencing control (start preparation, start, stop, aftercooling and control of auxiliaries) as well as all control functions.

Interfaces:

- Ethernet (twisted pair) for remote monitoring access
- Ethernet (twisted pair) for connection between engines
- Ethernet (twisted pair) for the Powerlink connection to the control input and output modules.

Connection to the local building management system according to the JENBACHER option list (OPTION)

- MODBUS-RTU Slave
- MODBUS-TCP Slave,
- PROFIBUS-DP Slave (120 words),
- PROFIBUS-DP Slave (190 words),
- ProfiNet Slave
- OPC DA Server

Control functions:

- Speed control in idle and in island mode
- Power output control in grid parallel operation, or according to an internal or external set point value on a case by case basis
- LEANOX control system which controls boost pressure according to the power at the generator terminals, and controls the mixture temperature according to the engine driven air-gas mixer
- Knocking control: in the event of knocking detection, ignition timing adjustment, power reduction and mixture temperature reduction (if this feature is installed)
- Load sharing between engines in island mode operation (option)
- Linear power reduction in the event of excessive mixture temperature and misfiring
- Linear power reduction according to CH4 signal (if available)
- Linear power reduction according to gas pressure (option)
- Linear power reduction according to air intake temperature (option)

Multi-transducer to record the following alternator electrical values:

- Phase current (with slave pointer)
- Neutral conductor current
- Voltages Ph/Ph and Ph/N
- Active power (with slave pointer)
- Reactive power
- Apparent power
- Power factor
- Frequency
- Active and reactive energy counter

Additional 0 (4) - 20 mA interface for active power as well as a pulse signal for active energy

The following alternator monitoring functions are integrated in the multi-measuring device:

- Overload/short-circuit [51], [50]
- Over voltage [59]
- Under voltage [27]
- Asymmetric voltage [64], [59N]
- Unbalance current [46]
- Excitation failure [40]
- Over frequency [81>]
- Under frequency [81<]

Lockable operation modes selectable via touch screen:

- "OFF" operation is not possible, running units will shut down immediately.
- "MANUAL" manual operation (start, stop) possible, unit is not available for fully automatic operation.
- "AUTOMATIC" fully automatic operation according to external demand signal:

Demand modes selectable via touch screen:

- external demand off („OFF“)
- external demand on („REMOTE“)
- override external demand („ON“)

Malfunction Notice list:

Shut down functions e.g.:

- Low lube oil pressure
- Low lube oil level
- High lube oil level
- High lube oil temperature
- Low jacket water pressure
- High jacket water pressure
- High jacket water temperature
- Overspeed
- Emergency stop/safety loop
- Gas train failure
- Start failure
- Stop failure
- Engine start blocked
- Engine operation blocked
- Misfiring
- High mixture temperature
- Measuring signal failure
- Overload/output signal failure
- Generator overload/short circuit
- Generator over/undervoltage
- Generator over/underfrequency
- Generator asymmetric voltage
- Generator unbalanced load

- Generator reverse power
- High generator winding temperature
- Synchronizing failure
- Knocking failure

Warning functions e.g.:

- Cooling water temperature min.
- Cooling water pressure min.
- Generator winding temperature max.

Remote signals:

(volt free contacts)

1NO = 1 normally open

1NC = 1 normally closed

1COC = 1 change over contact

- | | |
|---|-----|
| • Ready for automatic start (to Master control) | 1NO |
| • Operation (engine running) | 1NO |
| • Demand auxiliaries | 1NO |
| • Collective signal "shut down" | 1NC |
| • Collective signal "warning" | 1NC |

External (by others) provided command/status signals:

- | | |
|---------------------------------------|----|
| • Engine demand (from Master control) | 1S |
| • Auxiliaries demanded and released | 1S |

Single synchronizing Automatic

For automatic synchronizing of the module with the generator circuit breaker to the grid by PLC- technology, integrated within the module control panel.

Consisting of:

- Hardware extension of the programmable control for fully automatic synchronization selection and synchronization of the module and for monitoring of the generator circuit breaker closed signal.
- Lockable synchronization selection via touch screen with the following selection modes:
 - "MANUAL" Manual initiation of synchronization via touch screen button followed by fully automatic synchronization of the module
 - "AUTOMATIC" Automatic module synchronization, after synchronizing release from the module control
 - "OFF" Selection and synchronization disabled
Control of the generator circuit breaker according to the synchronization mode selected via touch screen.
 - "Generator circuit breaker CLOSED/ Select" Touch-button on DIA.NE XT
 - "Generator circuit breaker OPEN" Touch-button on DIA.NE XT

Status signals:

Generator circuit breaker closed
Generator circuit breaker open

Remote signals:

(volt free contacts)

Generator circuit breaker closed 1 NO

The following reference and status signals must be provided by the switchgear supplier:

- Generator circuit breaker CLOSED 1 NO
- Generator circuit breaker OPEN 1 NO
- Generator circuit breaker READY TO CLOSE 1 NO
- Mains circuit breaker CLOSED 1 NO
- Mains circuit breaker OPEN 1 NO

Mains voltage 3 x **480/277V** or 3x 110V/v3 other measurement voltages available on request
Bus bar voltage 3 x **480/277 V** or 3x 110V/v3 – other measurement voltages available on request
Generator voltage 3 x **480 V** or 3x 110V/v3 – other measurement voltages available on request

Voltage transformer in the star/star connection with minimum 50VA and Class 0,5

The following volt free interface-signals will be provided by JENBACHER to be incorporated in switchgear:

- CLOSING/OPENING command for generator circuit breaker
(permanent contact) 1 NO + 1 NC
- Signal for circuit breaker undervoltage trip 1 NO

Maximum distance between module control panel and engine/interface panel: 99ft
Maximum distance between module control panel and power panel: 164ft
Maximum distance between module control panel and master control panel: 164ft
Maximum distance between alternator and generator circuit breaker: 99ft

1.11 Motor control panel – Container design

Sheet metal IEC enclosure, components and assembly UL listed.
For distribution and protection of the module and container auxiliaries.
With cubicle lighting.

Dimensions:

- Height: 71 inch (1800 mm)
- Width: 39 inch (990 mm)
- Depth: 16 inch (405 mm)

Equipment:

Equipped with IEC type starters for each motor

With safety disconnect switches for every load

With step down transformer 480/120V, 4kVA for container consumers

1.11.01 Remote messaging over MODBUS-TCP

Data transfer from the JENBACHER module control system to the customer's on-site central control system via MODBUS TCP using the ETHERNET 10 BASE-T/100BASE-TX protocol TCP/IP.

The JENBACHER module control system operates as a SLAVE unit.

The data transfer via the customer's MASTER must be carried out in cycles.

Data transmitted:

Fault messages, operating messages, measured values (generator power, oil pressure, oil temperature, cooling water pressure, cooling water temperature, etc.) according to JENBACHER standard (interface list).

JENBACHER limit of supply:

RJ45 socket at the interface module in the module control cabinet

1.11.06 Remote Data-Transfer with DIA.NE XT4

General

DIA.NE XT4 offers remote communication using an Ethernet connection.

1.) DIA.NE XT4 HMI

DIA.NE XT4 HMI is the Human-Machine-Interface of DIA.NE XT4 engine control and visualization system for JENBACHER gas engines.

The system offers extensive facilities for commissioning, monitoring, servicing, and analysis of the site.

By installation of the DIA.NE XT4 HMI client program it can be used to establish connection to site, if connected to a network and access rights are provided.

The system runs on Microsoft Windows Operating systems (Windows XP, Windows 7, Windows 8, Windows 10)

Function

Functions of the visualization system at the engine control panel can be used remotely. These functions provide control, monitoring, trend indications, alarm management, parameter management, and access to long term data recording. By providing access to multiple systems, also with multiple clients in parallel, additional useful functions are available like

- Multi-user system
- Remote control
- Print and export functions
- Data backup.

The DIA.NE XT4 is available in several languages.

Option - Remote demand/blocking

If the service selectors switch at the module control panel is in position "Automatic" and the demand-selector switch in position "Remote", it is possible to enable (demanded) or disable (demand off) the module with a control button at the DIA.NE XT4 HMI

Note:

With this option, it makes no sense to have an additional clients demand (via hardware or data bus) or a self-guided operation (via JENBACHER master control, grid import /export etc.).

Option - Remote - reset (see TA-No. 1100-0111 chapter 1.7 and 1.9)

Scope of supply

- Software package DIA.NE XT4 HMI Client Setup (Download)
- Number of DIA.NE XT4 HMI - Client user license (Simultaneous right to access of one user to the engine control)

Nr. of license	Access
1	1 Users can be logged in at the same time with a PC (Workplace, control room or at home).
2 - "n" (Optional)	2- "n" Users can be logged in at the same time with a PC (Workplace, control room or at home). If 2- "n" users are locally connected at Computers from office or control room, then it is not possible to log in from home.

Caution! This option includes the DIA.NE XT4 HMI client application and its license only – NO secured, encrypted connection will be provided by JENBACHER! A secured, encrypted connection – which is mandatory – has to be provided by the customer (via LAN connection or customer-side VPN), or can be realized by using option myPlant™.

Customer requirements

- Broad band network connection via Ethernet(100/1000BASE-TX) at RJ45 Connector (ETH3) at DIA.NE XT4 server inside module control panel
- Standard PC with keyboard, mouse or touch and monitor (min. resolution 1024*768)
- Operating system Windows XP, Windows 7, Windows 8, Windows 10
- DirectX 9.0 c compatible or newer 3D display adapter with 64 MB or higher memory

2.) myPlant™

myPlant* is the remote data transfer and diagnostics solution from JENBACHER

	BASIC	CARE	PROFESSIONAL
basic / advanced monitoring			
Liver operating status	✓	✓	✓
Historic and live data trending		✓	✓
Alarm management and notification	Alarm management only	✓	✓
Access to all engine documents	✓	✓	✓
Mobile app	✓	✓	✓

Daily status logbooks	✓	✓	✓
Remote access to engine controller		✓	✓
Fleet management		✓	✓
Engine status notifications (SMS/Email)		✓	✓

increased productivity / strong performance

Recommended maintenance ¹ (coming soon)	✓	✓	✓
Support case management ¹	✓	✓	✓
Predictive maintenance for spark plugs, oil and air filters ²	Spark plugs lifetime prediction only	✓	✓
Oil & coolant quality monitoring ³		✓	✓
Fleet emission monitoring ⁴	Engine emission monitoring only	✓	✓

artificial intelligence & predictive analytics

Operator analytics package			✓
Historic performance analysis			✓
User-defined monitoring			✓
On demand: Access to myPlant data via API (Application Programming Interface) service ⁵			✓

¹ Available soon for JENBACHER direct markets only

² Spark plugs, oil and air filters data might not always be available and is depending on the engine version/type and the sensors installed

³ Oil and coolant reports are available in myPlant for the following laboratories: Spectro, JetCare, Polaris, MIC GSM

⁴ May require additional hardware installation for emission monitoring (available as upgrade)

⁵ Might require development work on customer/service provider side and includes 70 API calls per engine per month

Scope of supply

- Access to myPlant™
- Integration of the plant in the myPlant™ system
- Access to Basic and Care level as per new installation contract
- Access to Professional level via separate contract

Equipment to be provided by the customer

- Permanent Internet connection (wired or wireless)
(see also option 4)
- Technical requirements as per TA 2300-0008
- Outward data connection (from the plant server to the Internet) - INWARD connections are NOT PERMITTED!

CAUTION: The customer must take technical precautions to ensure that direct access to the plant server from the Internet is prevented (e.g. by means of a firewall):

This security measure CANNOT be assumed and guaranteed by JENBACHER

3.) Mobile Internet (OPTION)

Connection Plant - Customer via secured Internet - connection

See also technical instruction **TA 2300 - 0006**

Scope of delivery

- Mobile Internet router with antenna to connect to the DIA.NE Server XT4

Customer requirements

- SIM card for 3G / 4G

4.) Network overview

For information only!

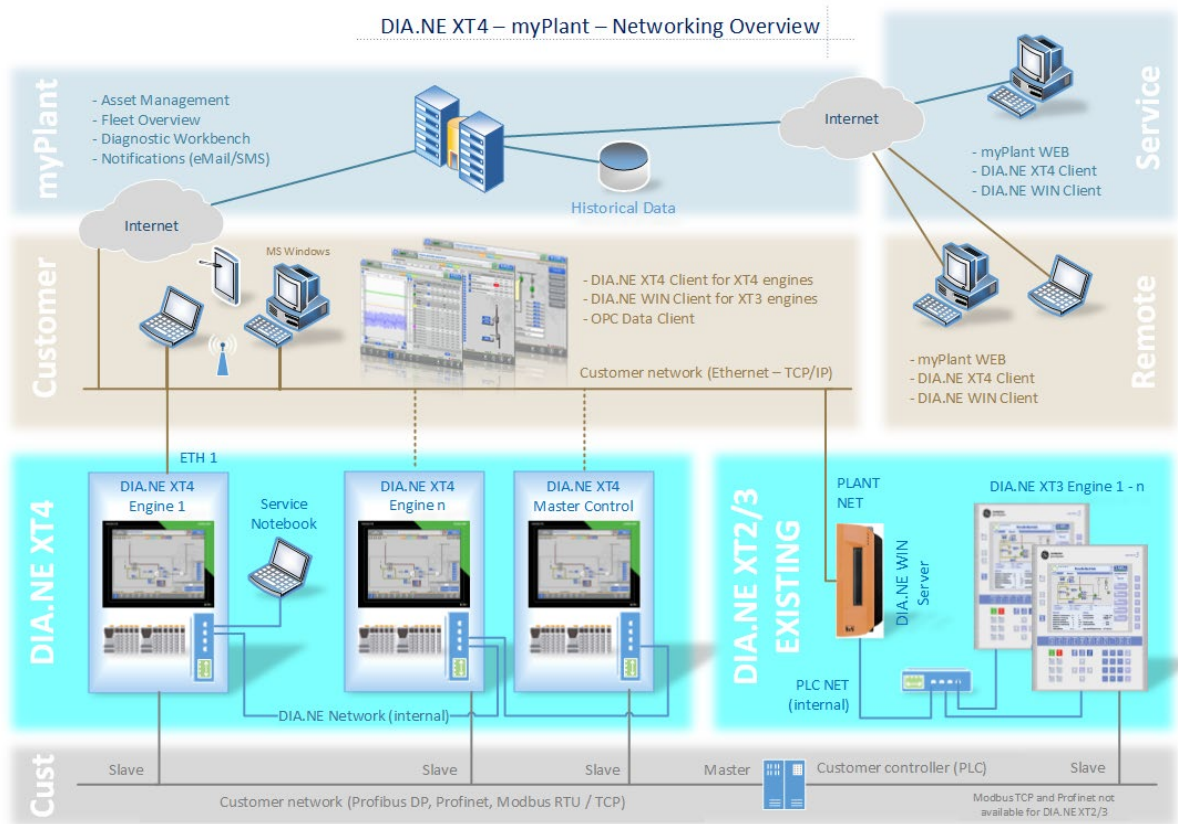

1.11.25 Control Strategy and Options (Type 3 Container)

Control Strategy – The following control modes will be available in the Diane Control

- **Grid Parallel with KW Control** – Real Power Load Control of the Generator set will be either via a 4-20mA input from the customer representing a unit KW load setpoint or a KW load setpoint entered on the Diane XT4 screen. Upon breaker closure, the unit will ramp to the setpoint at a maximum rate of (Rated Unit KW) / 180 seconds.
- **Grid Parallel with PF Control** – Reactive Power Load Control of the Generator set will be either via a 4-20mA input from the customer representing a unit Power Factor setpoint or a Power Factor setpoint entered on the Diane XT4 screen. Upon breaker closure, the unit will maintain the setpoint.
- **Grid Parallel with Import/Export Control** - Load Control via an Import/Export KW level entered on the Diane XT4 screen. Required will be a customer 4-20mA signal representing the Site KW (Imported and/or Exported Power) that is to be controlled. Upon breaker closure, the unit will ramp to a load that will drive the KW value represented by the 4-20mA input signal to the level entered on Customer Import/Export Setpoint entered in the Diane XT4 screen. Once at the setpoint, the unit will raise and lower load to maintain this value. If the generator load required to maintain this setpoint drops below the minimum load level of the generator set, the unit 52G circuit breaker will be opened.

- Island Mode Operations with Blackout Starting – Island Operations with Black start capability will allow the engine to start and run without utility being present. The engine will be able to start the engine on battery power, close the generator breaker against a dead bus, and operate independently of a utility power source. The customer must ensure that there is sufficient fuel gas and pre-chamber gas at pressure in the event of a Type 6 engine so configured. The engine will start without the normal confirmation of engine block temperature or operation of a circulating AC water pump. It will be required of the operators that once the engine is connected to the generator bus, power to the engine auxiliaries be restored. Load Management is expected to be limited by the operators to the limits of the engine, as per Jenbacher TI 2108-0031. This system will work in conjunction with a Jenbacher Master Synchronizing Control (see appropriate Spec Section) if so equipped. If this is a single unit and synchronization with the utility after assuming operations is required, a *Grid Parallel with Single Unit Island Operations* option will be required.

Per Unit Hot Water Loop Controls - Hot Water Loop Panel Controls and Software to include:

- Hot Water Pump (Panel Control Parts and SW Only) - The option will add specific contact output and feedback input to/from an MCC for the Hot Water Pump. This will include relays and software.
- Hot Water Monitoring (Panel Control Parts and SW Only) - This option will monitor 3 hot water loop switches, flow, pressure, and temperature. This option includes hardwired relays added to the trip loop, and internal software
- Hot Water Return Temperature Control (Panel Parts and SW Only) - This feature will provide all necessary controls to operate a 3 Way temperature control valve. The customer will provide a PT100 as a feedback signal and the Diane will provide a 4-20mA Analog Output to a customer provided valve. Control and Display Software are also provided.

Per Unit Miscellaneous Controls - Diane XT4 System will be provided with the following additional features to operate a customer enclosure

- Additional Emergency Stop Signals - Additional Terminals for customer Estop switches
- Audible and Visual Alarm Indications - Hardware and software to drive a customer provided horn and strobe. Power for these devices is provided from the control system and is 24VDC
- SCR Control Signals – 2 additional discrete inputs and 1 analog will be required:
 - Discrete In 1 - Unit Operation/Engine Running (SSL20) to start the unit
 - Discrete In 2 - SCR Alarm (SS69) for display on the alarm Diane XT screen.
 - Analog Out 1 – Generator Power (0-100% = 4-20mA) for control of the SCR spray mechanism.
- Gas Flow Meter Trending - Gas Flowmeter Trending and Display (Flowmeter not included). Option includes a 4-20mA input that will accept the pressure and temperature corrected gas flow from a customer provided flow meter computer and will incorporate the signal into trending and displays in the Diane system.
- Gas Flow Meter Correction - Gas Flowmeter temperature and pressure compensation. Option includes three (3) 4-20mA inputs that will represent actual measured flow, pressure, and temperature. Along with a customer provided flow meter calibration sheet, these 3 signals will be input to a calculation that will compensate the flowmeter flow signal to current gas conditions. The results will be incorporated into trending and displays in the Diane system.

- Exhaust By-Pass Control -The exhaust by-pass consists of two flaps (one open, one closed) housed in a tee section of piping, which are controlled by a single actuator. The position of the by-pass is determined by the outlet temperature of the process heat exchanger. A PT100 sensor is used to send the outlet temperature of the process heat exchanger to the DIA.NE XT. The DIA.NE XT monitors this temperature, and if the temperature is at or above set point, moves the flaps to reduce the flow to the Exhaust Heat Exchanger while increasing the flow to the exhaust bypass. For temperatures below set point, all flow is directed through the Exhaust Heat Exchanger (analog output = 20 mADC).

[4 mADC = full bypass, 20 mADC = full Enalco. A broken wire or loss of signal of the PT100 sensor, the heat exchanger will be bypassed.]

- Included in the control:
 - Dig. Input Release exhaust gas bypass
 - Analog Input Exhaust gas temperature after EHGE
 - Analog Input Temperature heating water supply
 - Analog Output 4 – 20mA Setpoint bypass flap

1.20.03 Starting system

Starter battery:

2 piece 12 V AGM battery, 125 Ah (according to DIN 72311).

Battery voltage monitoring:

Monitoring by PLC.

Battery charging equipment:

Capable for charging the starter battery with I/U characteristic and for the supply of all connected D.C. consumers.

Charging device is mounted inside of the module interface panel or module control panel.

• General data:

- | | |
|--------------------------|---|
| • Power supply | 3 x 320 - 575 V, 47 - 63 Hz |
| • max. power consumption | 1040 W / 1550 W (5 sec) |
| • Nominal D.C. voltage | 24 V (+/-1%) |
| • Voltage setting range | 24V to 28V (adjustable) |
| • Nominal current (max.) | 40 A |
| • Degree of protection | IP20 to IEC 60529 |
| • Operating temperature | 32 °F – 158 °F (0 °C - 70 °C) |
| • Protection class | 1 |
| • Humidity class | 3K3, no condensation. |
| • Natural air convection | |
| • Standards | EN60950, EN50178
UL/cUL (UL508 / UL 60950-1) |

Signalling:

Green Led: Output voltage > 21.6V

Control accumulator:

- Pb battery 24 VDC/18 Ah

1.20.05 Electric jacket water preheating

Installed in the jacket water cooling circuit, consisting of:

- Heating elements
- Water circulating pump

The jacket water temperature of a stopped engine is maintained between 133 °F (56°C) and 140°F (60°C), to allow for immediate loading after engine start.

1.20.08 Flexible connections

Following flexible connections per module are included in the JENBACHER -scope of supply:

No.Connection	Unit	Dimension	Material
2 Warm water in-/outlet	IN/LBS	3"/145	Stainless steel
1 Exhaust gas outlet	IN/LBS	10"/145	Stainless steel
1 Fuel gas inlet	IN/LBS	4"/232	Stainless steel
2 Intercooler in-/outlet	IN/LBS	2½"/	Stainless steel
2 Lube oil connection	IN	1.1	Hose

Seals and flanges for all flexible connections are included.

2.00 Electrical equipment

Totally enclosed floor mounted sheet steel cubicle with front door wired to terminals. Ready to operate, with cable entry at bottom. Naturally ventilated or with forced ventilation.

Protection: IP 42 external, NEMA 12
IP 20 internal (protection against direct contact with live parts)

Design according to EN 61439-2 / IEC 61439-2 / UL 508 A and ISO 8528-4.
Ambient temperature 41 - 104 °F (5 - 40 °C), 70 % Relative humidity

Standard painting: Panel: RAL 7035
Pedestal: RAL 7020 (Rittal TS8)
RAL 7020 (Rittal VX25)

2.02 Grid monitoring device

Standard without static Grid - 60Hz alternator

Function:

For immediate disconnection of the generator from the grid in case of grid failures.

Consisting of:

- High/low voltage monitoring
- High/low frequency monitoring
- Specially adjustable independent time for voltage and frequency monitoring
- Vector jump monitoring or df/dt monitoring for immediate disconnection of the generator from the grid for example at short interruptions
- Indication of all reference dimensions for normal operation and at the case of disturbance over LCD and LED
- Adjusting authority through password protection against adjusting of strangers

Scope of supply:

Digital grid protection relay with storage of defect data, indication of reference dimensions as well as monitoring by itself.

Grid protection values:

Parameter	Parameter limit	Max time delay[s]	Comments
59-61Hz			Do work normal
f<[ANSI 81U]	59Hz	0.5	Load reduction with 10%/HZ below 59Hz!
f<<[ANSI 81U]	58.5Hz	0.1	
f>[ANSI 81O]	61.5Hz	0.1	Load reduction with 30%/HZ above 61Hz!
U<[ANSI 27]	90%	1	Load reduction with 1%P /%U below 95%
U<< [ANSI 27]	80%	0.2	Load reduction with 1%P /%U below 95%
U> [ANSI 59]	110%	30	Load reduction with 1%P /%U above 105%
U>> [ANSI 59]	115%	0.2	Load reduction with 1% P/%U above 105%

Df/dt [ANSI 81R]	2Hz/s, 5 Periods		Cos phi range:
Or	Or		0.8ind (overexcited)
Vector shift	8° -3pol		- 1
[ANSI 78]			

2.04 Generator Low Voltage switchgear (for container design)

Sheet metal enclosure, UL listed, front-access

Dimensions:

- Height: 80 inches (2032 mm)
- Width: 28 inches (700 mm)
- Depth: 32 inches (800 mm)

Generator circuit breaker details

- In = **XXXX** A, drawn out type
- Short circuit breaking capacity: 65kA
- Spring drive 24VDC
- Close coil 24VDC
- Shunt trip coil 24VDC
- Under-voltage trip coil 24VDC
- Auxiliary contacts (a/b)
- Programmable Short Circuit Protection (Instantaneous and Duration)

Cabinet Fitted with

- 2 PT fused sets (Bus side/Gen side, 3 PTs in a Wye to Wye configuration)
- Surge Suppression

Per Phase Bus Bar Terminations and Ground Bar predrilled for customer terminations (maximum 4 cables per phase (Hardware not provided).

2.12 Gas warning device

Function:

The gas warning device continuously monitors the radiated air in the engine room and warns against gases which are injurious to persons' health and against explosive gas concentrations.

The measuring head (catalytic sensor) is attached on the covering or nearby the ground, dependent upon the gas source.

Scope of supply:

- Alarm unit voltage: 24VDC

0,03 inch (0,75 mm) galvanized steel sheet) is required to keep the sound pressure level of the container (65 dB(A) in 32 ft (10 m)).

3.10.03 Cooling system – dual-circuit radiator

The heat produced by the engine (jacket water, lube oil, intercooler) is dissipated through a radiator, installed outside.

Consisting of:

- Radiator
- Pump
- Electrical control
- Expansion tank

The radiator is designed for an ambient temperature of 95°F (35°C). Special versions for higher ambient temperatures are available upon request.

3.20 Container

40' ISO STEEL CONTAINER, Module Installation

Dimensions:

- Length: 40 ft (12192 mm)
- Width: 8 ft (2438 mm)
- Height: 8 ft, 6 in (2591 mm)

Sound pressure level

65 dB (A) at 32 ft (10 m) (surface sound pressure level according to DIN 45635)

See comments under MC 3.03.01

Ambient temperature:

The container is designed for an ambient temperature from **-4°F (-20°C) to 90°F (32°C)**.

Other temperatures are available upon request.

Base frame:

Self-supporting, i.e. the base frame is designed to withstand static loads from the installation of parts such as the engine, control panels, exhaust gas silencer and radiator.

To lift (to load) the container 4 screw able carrier lugs are mounted at the top of the container.

Construction:

Trapezoidal corrugated steel sheeting welded between the base frame and the top frame.

The sound absorbent surfaces are comprised of rock wool covered with perforated plating.

The container is of a weatherproof design and the roof is suitable for construction work.

A double door to bring in the engine is situated at the front of the container beside the air outlet.

There is a door into the control room at the front wall on the side of air inlet.
A door into the engine room is situated at the long side of the container.

The doors (engine room and control room) are fitted with identical cylinder locks. The doors are designed as emergency doors which could be opened in direction of the escape route. They are identified as such and can be opened from inside without other assistance (panic lock).

Dimension of door: appr. 3.28 ft (1000 mm) x 6.56 ft (2000 mm) (W x H)

Engine room:

The floor is made of steel sheet (checker – or diamond plate) and designed as a tightly sealed pan. This pan is used to collect any oil-leak of the lube oil circuit (engine and extension tank).

Connections from/to the engine room consist of:

- Top: Cooling water in/outlet; welded flange
 Exhaust gas outlet; tightly closed
- Roof:
 Suspensions for cable trough, gas train, gas pipes, ...
- Wall:
 Gas inlet; welded flange
 The wall between engine room and control room is design with recesses for the cables.

Control room:

The control room is ventilated by a lockable air intake opening. The air is aspirated by the fans of the engine room. For the cable's entry, a recess at the floor of the control room is planned. The control room is equipped with a plastic covering for shipment.

Module and container installation are essentially performed as follows:

- Installation and setup of the module
- Installation of the control equipment in a separate control equipment room
- Installation of the gas train
- Installation of the lube oil equipment
- Installation of the air intake and outlet ventilation system
- Installation of the exhaust silencer on the roof
- Installation of the radiator on the roof
- Installation of lighting in the container
- Installation of the auxiliary electrical installations
- Completion of exhaust, fuel, oil, and water piping, according to the defined scope of supply, including all necessary fittings, flexible connections, and reinforcements.
- Footboard above the tubes
- Rain drain
- Total signage

Fire protection classification:

The container is not classified for fire protection.

Coating:

- Installation:
 - Oil resistant base

- Synthetic resin as coating varnish
- Color Container:
RAL6018 (green)

3.50 Power and control cable

- Control cable between the module control panels, cable length max. 32 ft (10 m)
- Power cable between generator output terminal and following connection point, cable length max. 32 ft (10 m)
- Starter cable from the batteries to the starter, cable length max. 16 ft (5 m)

3.71 Vibration Switch

A structural Vibration Switch will be installed on the package base frame to detect excessive vibrations. A signal will be sent to the control panel to indicate an alarm condition.

3.73 Seismic Protection - Container

The container has been designed and constructed to meet, at a minimum, the local seismic and wind loading criteria per ASCE/SEI 7. Any additional requirements identified by the Buyer from the project specific requirements have also been designed into the container. The container will be supplied with supports, brackets, attachment point or other necessary device to enable securing to meet the design requirements. Anchor design and hardware for any required foundation anchoring are not included.

Details will be provided at first drawing submittal.

4.00 Delivery, installation, and commissioning

4.01 Carriage

According to contract.

4.02 Unloading

Unloading, moving of equipment to point of installation, mounting and adjustment of delivered equipment on intended foundations is not included in JENBACHER scope of supply.

4.03 Assembly and installation

Assembly and installation of all JENBACHER -components is not included in JENBACHER scope of supply.

4.04 Storage

The customer is responsible for secure and appropriate storage of all delivered equipment.

4.05 Emission measurement with exhaust gas analyzer

Emission measurement by JENBACHER personnel, to verify that the guaranteed toxic agent emissions have been achieved (costs for measurement by an independent agency will be an extra charge).

5.01 Limits of delivery - Container

Electrical

- Module:
At terminals of generator circuit breaker

Mechanical

Suitable bellows and flexible connections **must be provided locally** for all connections.

Warm water

At inlet and outlet flanges on container

Exhaust gas

At exhaust gas outlet flange on top of the container; special stack provided locally

Combustion air

The air filters are set mounted, no external ductwork is necessary

Fuel gas

At inlet flange of the container

Lube oil

At lube oil connections on container

Condensate

At the condensate drains on container.

Insulation

Insulation of heat exchangers, pipework and exhaust gas silencer is not included in our scope of supply and must be provided locally.

5.02 Factory tests and inspections

The individual module components shall undergo the following tests and inspections:

5.02.01 Engine tests

Carried out as combined Engine- and Module test according to DIN ISO 3046 at JENBACHER test bench. The following tests are made at 100%, 75% and 50% load, and the results are reported in a test certificate:

- Engine output
- Fuel consumption
- Jacket water temperatures
- Lube oil pressure

- Lube oil temperatures
- Boost pressure
- Exhaust gas temperatures, for each cylinder

5.02.02 Generator tests

Carried out on test bench of the generator supplier.

5.03 Documentation

List of standard pre-documentation provided based on the technical status at the time of order receipt:

- Module drawing **1)**
- Technical diagram **1)**
- Drawings of the cabinet views **3)**
- Electrical interface list **2)**
- Technical specification of the control system **2)**

Before delivery (depending on progress in ordering the components, on request)

- Technical drawings for BoP components/accessories supplied separately (if included in scope of supply of INNIO Jenbacher GmbH & Co OG) **1)**

Upon delivery

- Circuit diagrams **3)**
- Cable list **3)**

Delivered with the engine

- Brief instructions (transport, erection, moving) **1)**

For commissioning

- Operation and maintenance instructions **4)**
- Spare parts catalogue **4)**
- Original supplier operation and maintenance instructions for any BoP components (installed in the INNIO Jenbacher GmbH & Co OG scope of supply) as Appendix **1)**

All the components found in the INNIO Jenbacher GmbH & Co OG scope of supply are described in the operation and maintenance instructions, and in the spare parts catalogue.

In addition, the manufacturer's original operation and maintenance instructions will be provided for every BoP component, in German and English as standard, as an Appendix for the operation and maintenance manual provided.

Additional costs of producing or providing the required documents using the KKS (power station coding system) and/or integration in subcontractors' documentation, or additional approval, design and proof of testing documentation must be negotiated or ordered separately.

This standard offer does not include:

- Approval documentation
- Design documentation
- Proof of testing documentation
- Printed copies and digital off-line versions (e.g. printed versions, CD, pdf, etc.) must be negotiated separately and ordered accordingly.

Appendix E

Project Cost Summary Detail

<u>Multiplier</u>	<u>Percentage</u>
Engineering:	See Chart Below
Construction Management:	Use same as Engineering above
Engineering Services During Construction:	4%
Environmental:	4%
Administration:	2%

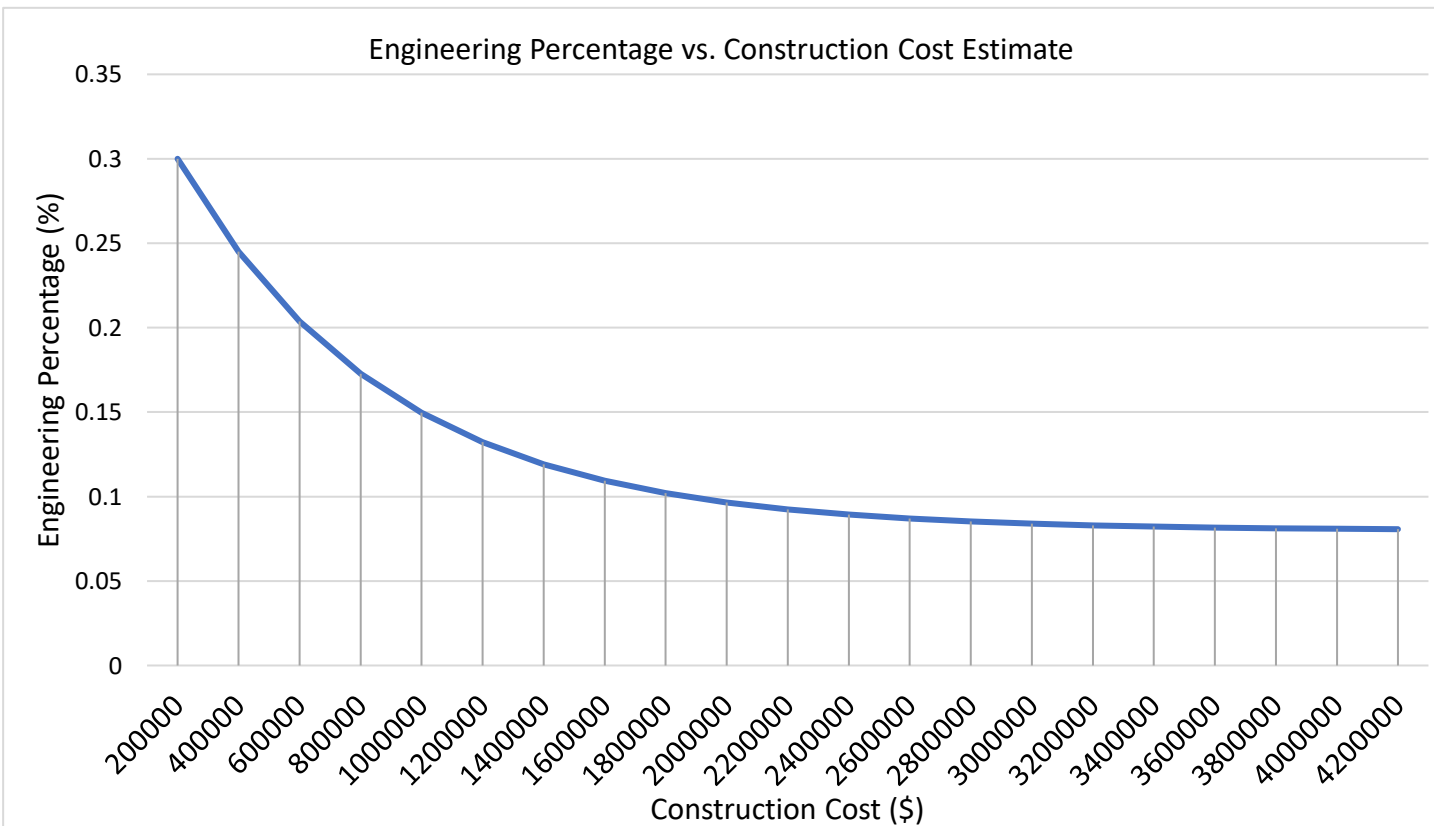
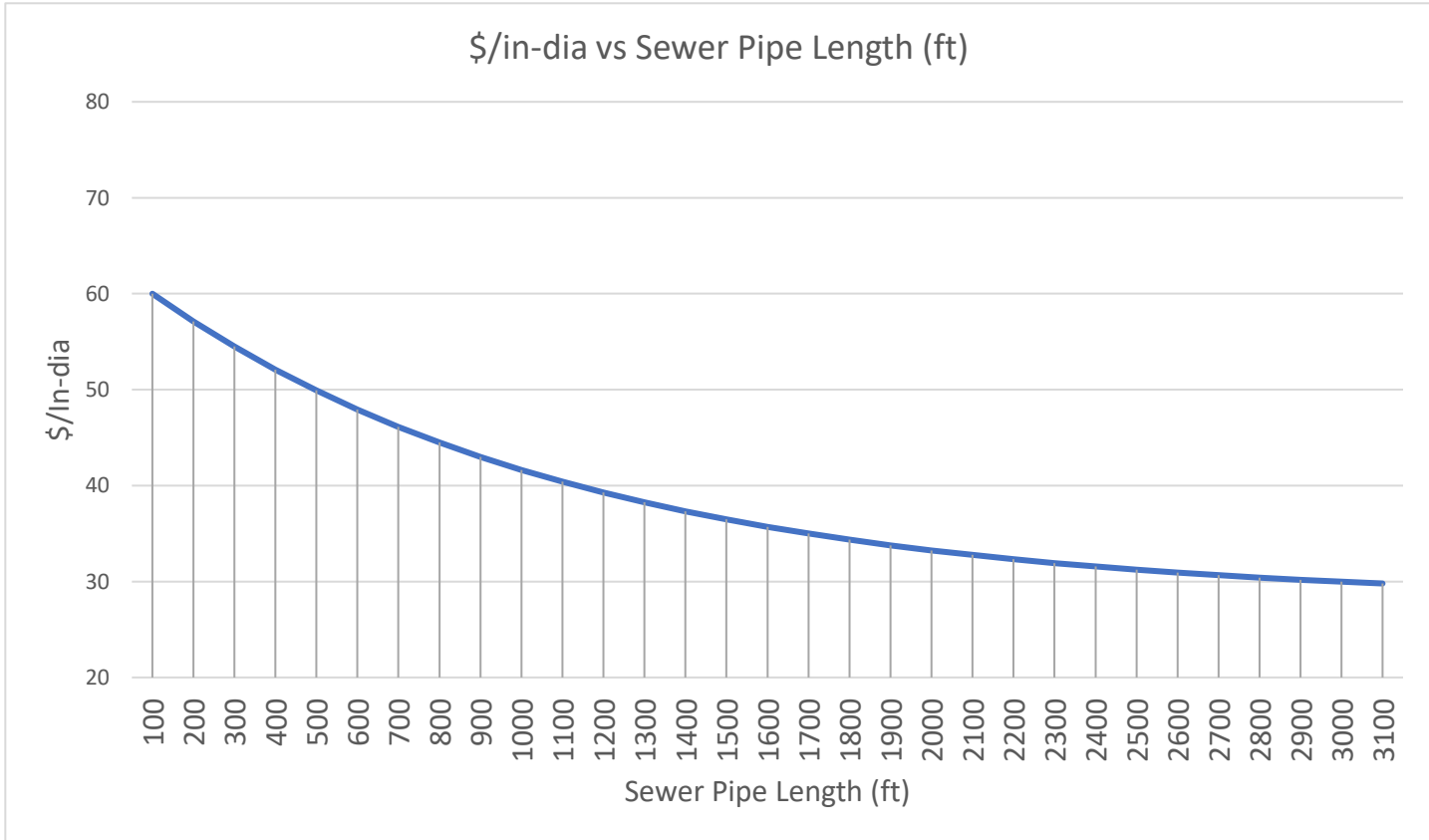

Cajon St, Cypress Ave to Fern Ave, Pipeline Upsizing (P-1)

Item No.	Item Description	Unit	Estimated Quantity	Unit Price	Item Total
1	Cajon St 12-inch Replacement	LF	1,350	\$456	\$ 615,600
Construction Total					\$ 615,600
<i>Soft Costs (Medium Project):</i>					
Engineering (18%)					\$ 112,519
Construction Management (10%)					\$ 61,560
Engineering Services During Construction (2%)					\$ 12,312
Environmental (2%)					\$ 12,312
Administration (2%)					\$ 12,312
Project Total					\$ 827,000

Cajon St at Citrus Ave Pipeline Upsizing (P-2)

Item No.	Item Description	Unit	Estimated Quantity	Unit Price	Item Total
1	Cajon St 15-inch Replacement	LF	100	\$960	\$ 96,000
Construction Total					\$ 96,000
<i>Soft Costs (Medium Project):</i>					
Engineering (30%)					\$ 28,800
Construction Management (10%)					\$ 9,600
Engineering Services During Construction (2%)					\$ 1,920
Environmental (2%)					\$ 1,920
Administration (2%)					\$ 1,920
Project Total					\$ 141,000

Alabama St Pipeline Upsizing and Rerouting (P-3)

Item No.	Item Description	Unit	Estimated Quantity	Unit Price	Item Total
1	New 36-inch in Alabama St	LF	2,700	\$1,116	\$ 3,013,200
2	New 24-inch in San Bernardino Ave	LF	920	\$1,008	\$ 927,360
3	Install concrete plug to abandoned 3,100 LF of 24-inch and 30-inch pipe	LS	1	\$1,500	\$ 1,500
Construction Total					\$ 3,942,060
<i>Soft Costs (Medium Project):</i>					
Engineering (10%)					\$ 394,206
Construction Management (10%)					\$ 394,206
Engineering Services During Construction (2%)					\$ 78,841
Environmental (2%)					\$ 78,841
Administration (2%)					\$ 78,841
Project Total					\$ 4,967,000

Brockton Ave Pipeline Upsizing (P-4)

Item No.	Item Description	Unit	Estimated Quantity	Unit Price	Item Total
1	Brockton Ave 10-inch Replacement	LF	350	\$520	\$ 182,000
Construction Total					\$ 182,000
<i>Soft Costs (Medium Project):</i>					
Engineering (30%)					\$ 54,600
Construction Management (10%)					\$ 18,200
Engineering Services During Construction (2%)					\$ 3,640
Environmental (2%)					\$ 3,640
Administration (2%)					\$ 3,640
Project Total					\$ 266,000

Citrus Plaza Dr Pipeline Upsizing (P-5)

Item No.	Item Description	Unit	Estimated Quantity	Unit Price	Item Total
1	Citrus Plaza Dr 27-inch Replacement	LF	350	\$1,404	\$ 491,400
Construction Total					\$ 491,400
<i>Soft Costs (Medium Project):</i>					
Engineering (20%)					\$ 100,146
Construction Management (10%)					\$ 49,140
Engineering Services During Construction (2%)					\$ 9,828
Environmental (2%)					\$ 9,828
Administration (2%)					\$ 9,828
Project Total					\$ 671,000

Nevada St Pipeline Upsizing (P-6)

Item No.	Item Description	Unit	Estimated Quantity	Unit Price	Item Total
1	Nevada St 30-inch Replacement	LF	1,900	\$1,020	\$ 1,938,000
Construction Total					\$ 1,938,000
<i>Soft Costs (Medium Project):</i>					
Engineering (11%)					\$ 203,574
Construction Management (10%)					\$ 193,800
Engineering Services During Construction (2%)					\$ 38,760
Environmental (2%)					\$ 38,760
Administration (2%)					\$ 38,760
Project Total					\$ 2,452,000

South Ave West of Franklin Ave Pipeline Upsizing (P-7)

Item No.	Item Description	Unit	Estimated Quantity	Unit Price	Item Total
1	South Ave 10-inch Replacement	LF	300	\$530	\$ 159,000
Construction Total					\$ 159,000
<i>Soft Costs (Medium Project):</i>					
Engineering (30%)					\$ 47,700
Construction Management (10%)					\$ 15,900
Engineering Services During Construction (2%)					\$ 3,180
Environmental (2%)					\$ 3,180
Administration (2%)					\$ 3,180
Project Total					\$ 233,000

Cajon St Between Highland Ave and Cypress Ave Pipeline Upsizing (P-8)

Item No.	Item Description	Unit	Estimated Quantity	Unit Price	Item Total
1	Cajon St 12-inch Replacement	LF	2,180	\$396	\$ 863,280
Construction Total					\$ 863,280
<i>Soft Costs (Medium Project):</i>					
Engineering (16%)					\$ 134,014
Construction Management (10%)					\$ 86,328
Engineering Services During Construction (2%)					\$ 17,266
Environmental (2%)					\$ 17,266
Administration (2%)					\$ 17,266
Project Total					\$ 1,136,000

South Ave at Franklin Ave Pipeline Upsizing (P-9)

Item No.	Item Description	Unit	Estimated Quantity	Unit Price	Item Total
1	South Ave 10-inch Replacement	LF	300	\$530	\$ 159,000
Construction Total					\$ 159,000
<i>Soft Costs (Medium Project):</i>					
Engineering (30%)					\$ 47,700
Construction Management (10%)					\$ 15,900
Engineering Services During Construction (2%)					\$ 3,180
Environmental (2%)					\$ 3,180
Administration (2%)					\$ 3,180
Project Total					\$ 233,000

Cajon St at Vine St Pipeline Upsizing (P-10)

Item No.	Item Description	Unit	Estimated Quantity	Unit Price	Item Total
1	Cajon St 15-inch Replacement	LF	300	\$795	\$ 238,500
Construction Total					\$ 238,500
<i>Soft Costs (Medium Project):</i>					
Engineering (29%)					\$ 68,916
Construction Management (10%)					\$ 23,850
Engineering Services During Construction (2%)					\$ 4,770
Environmental (2%)					\$ 4,770
Administration (2%)					\$ 4,770
Project Total					\$ 346,000

Redlands - Complete - March, 2022

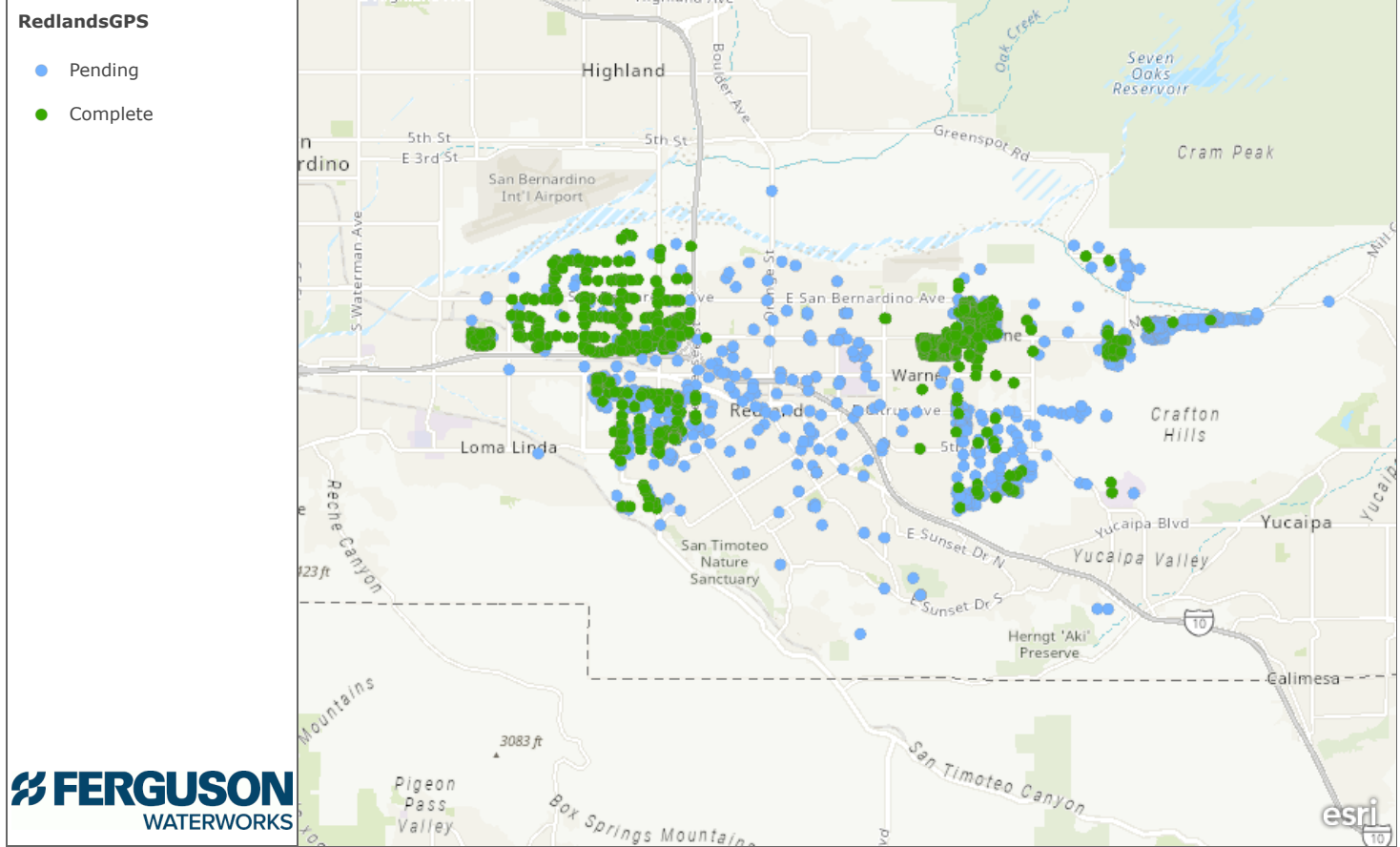



Esri, NASA, NGA, USGS | Loma Linda University, City of Redlands, County of Riverside, California State Parks, Esri, HERE, Garmin, SafeGraph, GeoTechnologies, Inc, METI/NASA, USGS, Bureau of Land Management, EPA, NPS, USDA

PMP 2021 Street Resurfacing Project

Location Map



-  PMP 2021 Completed
-  PMP 2021 Streets
-  City of Redlands



This map was produced by the City of Redlands, Geographic Information System. The City of Redlands assumes no warranty or legal responsibility for the information contained on this map. The data used to generate this map is dynamic in nature, therefore the information shown may or may not be the most current.

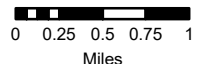

**MUNICIPAL UTILITIES AND ENGINEERING DEPARTMENT
CIP PROJECTS LIST**

PLANNING		Org Key	PL	Project Name	Project Phase	Progress	Consultant/Contractor	PM/Engineer	Current Budget
P1	WATER	501910		Tank Mixers Installation	PLANNING	1%		Paul	\$100,000.00
P2	WATER	501910	501009	Hinckley Sludge Press	PLANNING	1%		Paul	\$300,000.00
P3	WATER	501910		Tate WTP Transmission Line Assessment	PLANNING	1%		Paul	\$100,000.00
P4	WATER	501910	501007	Agate Well #2 Rehabilitation	PLANNING	5%		Paul	\$175,000.00
P5	WATER	501910		Wellhead Perchlorate Treatment Evaluation	PLANNING	1%		Paul	\$150,000.00
P6	WASTEWATER	521910		Alabama Septage Pond Remediation	PLANNING	25%		Johana	\$240,000.00
P7	WASTEWATER	521910		WWTP Drying bed leachate Remediation	PLANNING	1%		Johana	\$250,000.00
P8	GENERAL FUND	101400	400018	Citywide Storm Drain Improvements Project	PLANNING	1%		Gerard	\$500,000.00
P9	WATER	501910	501022	Hinckley/Tate Roof Repair Project	PLANNING	1%		Paul	\$100,000.00
P10	WATER	501910	501028	Reservoir Sites Fixed Generators (Tx. St. / C.C. / 5th Ave.)	PLANNING	30%		Veronica/Paul	\$750,000.00
P11	WATER	501910	501003	Sunset Reservoir Recoating & Improvement Project	PLANNING	5%		Kevin	\$700,000.00
Planning Projects - Cost Summary									\$3,365,000.00
DESIGN		Org Key	GL	Project Name	Project Phase	Progress	Consultant/Contractor	PM/Engineer	Current Budget
D1	WATER CONSV	501910	501002	Brookside Median Landscape Improvements	DESIGN	65%		Cecilia/Veronica	\$120,000.00
D2	PMP/GF	211910	211005	Alley Paving Improvements	DESIGN	50%		Elva	\$1,350,000.00
D3	PMP	211910	211004	SBCounty/Mentone/Redlands Paving Project	DESIGN	90%		Goutam	\$78,750.00
D4	ARTERIAL	252400	252001	Citrus Avenue Widening Project	DESIGN	65%		Elva	\$700,000.00
D5	HSIP C8	240400	F400001	HSIP Cycle 8 - Signal Preemption Project	DESIGN	65%	AGA Engineers, Inc.	Veronica	\$1,173,791.00
D6	HSIP C9	240400	F400003	HSIP Cycle 9 - Pedestrian In-Roadway Lights	DESIGN	65%		Veronica	\$250,000.00
D7	WATER	501910	501004	Hinckley WTP Backup Generator Replacement	DESIGN	25%		Paul	\$140,000.00
D8	ATP Cycle 3	240400	C400007	ATP East Valley Corridor Bike Rte Interconnect - Alabama	DESIGN	75%	KOA Consultants	Veronica	\$2,112,000.00
D9	TDA	240400	S241001	Orange Blossom Trail - Phase 3	DESIGN	99%		Gerard	\$918,722.00
D10	HSIP C8	240400	F400003	HSIP Cycle 8 - Pedestrian Heads Project	DESIGN	95%		Veronica	\$260,000.00
Design Projects - Cost Summary									\$7,103,263.00
BID & AWARD		Org Key	GL	Project Name	Project Phase	Progress	Consultant/Contractor	PM/Engineer	Current Budget
B1	TRAFFIC SIGNAL	253400	253007	Traffic Signal Improvements (Brockton/University)	BID & AWARD	65%		Elva	\$550,000.00
B2	GENERAL FUND	101400	400015	Citywide Sidewalk and ADA Ramp Replacement -Phase II	BID & AWARD	25%		Elva	\$1,132,000.00
Bid & Award Project - Cost Summary									\$1,682,000.00
CONSTRUCTION		Org Key	GL	Project Name	Project Phase	Progress	Contractor	PM/Inspector	Contract Amount
C1	WATER	501910	501039	2021 CIP Water Pipeline Replacement	CONST	5%	Borden Excavation, Inc.	Gerard	\$3,555,000.00
C2	WATER	501910	501006	Water System SCADA Design & Integration - Phase 2	CONST	5%	TESCO Controls, Inc.	Paul/Daniel	\$3,679,720.00
C3	SBCTA	254400	254002	I-10/Alabama Street Improvement (\$15,150,600)	CONST	5%	Ortiz Enterprises, Inc.	Kyle/Darren	\$2,506,921.00
C4	PMP	211910	211003	PMP 2021 Street Resurfacing Project	CONST	60%	Match Corp	Gerard/Frannie	\$9,235,780.00
C5	WATER	501910	501037	Citywide Potable Water Meter Replacements	CONST	95%	Ferguson Enterprises, LLC	Paul	\$1,815,000.00
C6	NON-POTABLE	531910	531006	Citywide Non-Potable Water Meter Replacement	CONST	95%	Ferguson Enterprises, LLC	Paul	\$93,000.00
C7	WATER	501910	501005	Wells and Booster Pump Maintenance	CONST	20%	General Pump Company, Inc.	Paul	\$1,034,181.10
C8	SBCTA	254400	254001	I-10/University Interchange Project (\$5,812,935)	CONST	80%	SBCTA/ADVANTEC/SEMA	Kyle/Darren	\$1,234,260.00
C9	WASTEWATER	521910	521006	MBR & Digester Improvements Project- Phase 1B	CONST	80%	GSE Construction Co. Inc.	Goutam/Darren	\$7,311,740.00
C10	WATER	501910	71060	2020 Citywide Pavement Repair for Water Projects	CONST	35%	Tryco General Engineering	Goutam/Daniel	\$429,020.00
Construction Projects - Cost Summary									\$30,894,622.10
Project Total Dollars									\$43,044,885.10